

STANDARD
GAS BOOSTER
SYSTEMS

Haskel[®]
an Accudyne Industries brand



sales@kenenergy.com.my

WHY CHOOSE HASKEL

Comprehensive systems for demanding high-pressure gas transfer and pressurization solutions.

From selection and design to manufacturing and installation, standard packages provide precision and performance for gas transfer, charging and storage applications.

Reliability

Haskel gas boosters are designed with the highest quality for longevity and easy maintenance. Haskel gas boosters use patented seal systems to give a long working life, providing the capability of transferring and pressurising a wide variety of gases.

Regular servicing by Haskel authorized service and repair centers extends the life of your equipment for continued optimum performance and can be carried out alongside planned maintenance programs.

Extensive Range

Haskel offers single acting, double acting and two stage models to cover a wide range of operating conditions up to pressures of 20,000 PSI (1379 Bar).

GAS BOOSTER SYSTEM FEATURES

- Pressurize gas from industrial gas bottles (up to 20,000 psi)
- Plumbed for inert gases in single arrangements
- Available in single-stage or two stage styles; selection is made on the grounds of gas pressure and flow requirements
- Supplied with a range of controls: air controls, air pilot switches (optional) for automated stop/start control, relief device, pressure isolation and vent valves
- All components are mounted and plumbed in an open stainless steel frame with a sloped front control panel
- Safety relief devices are standard on all gas booster systems for maximum operational safety
- Allows 90 to 95% use of cylinder gas to maintain process pressure when cylinder pressure drops
- Oxygen Cleaned units available
- Can charge a receiver to even higher-pressure level, thus storing a volume of gas for rapid release



APPLICATIONS

Gas accumulator charging

Pressure & leak testing various pressure containing components

Pressurization of gas cylinders

Gas transfer, boosting or mixing

SCOPE OF SUPPLY

1. Air driven gas booster with external pilot air modification to enable use of external air pilot switches to automatically start and stop the booster.
2. Adjustable inlet air pilot switch used to stop booster when the gas supply pressure falls below the adjusted minimum set point (optional).
3. Adjustable remote-set outlet air pilot switch used to stop booster when the outlet pressure reaches the adjusted maximum set point (optional).
4. Outlet pressure gauge, safe case design, 100mm diameter, panel mounted with bar/psi dual scale. Accuracy +/- 1% FSD.
5. Inlet pressure gauge, safe case design, 100mm diameter, panel mounted with bar/psi dual scale. Accuracy +/- 1% FSD.
6. Gas filter, 5 micron rated, used to stop any ingested contamination from entering the booster (e.g. while changing out gas supply bottles).
7. Roll bar frame with sloping operator panel into which the booster and controls are mounted. Frames are a brushed 316 stainless steel.
8. Combined air inlet filter regulator, with integral pressure gauge and on/off control valve. Air filter – in line with 40-micron filtration to maintain air drive quality. Adjustable air regulator used to set the air drive pressure, adjustable between 0 – 150 PSI. 25mm air gauge indicated the regulated air pressure setting. Manual on/off valve and speed control valve, panel mounted, used to adjust the cycling speed at which the booster operates.
9. Adjustable Haskel relief valve used to protect the booster and other components from over pressurization, piped to a common vent connection.
10. Adjustable remote-set air pilot regulator used to change the set point for the remote set outlet air pilot switch (optional).
11. 25mm air gauge, panel mounted, used to indicate the adjustable remote set regulator adjusted pressure.
12. Manually operated BuTech outlet isolation valve, panel mounted, piped to a common vent connection.
13. Manually operated BuTech outlet pressure vent valve, panel mounted, piped to a common vent connection.
14. Interstage cooler. A Haskel design integral tube and shell cooler used to reduce the boosted gas temperature.

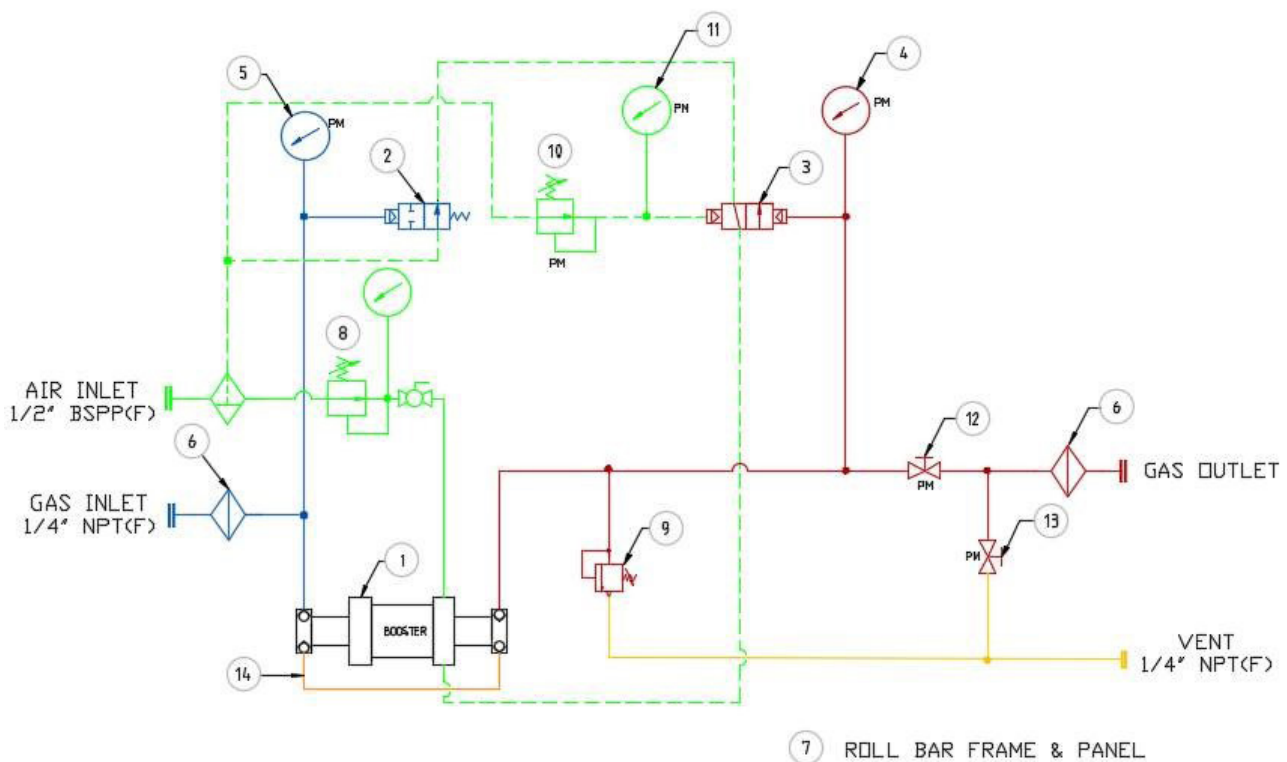



INNOVATION THAT SHAPES THE FUTURE

Haskel leads the world in the design, manufacture, and supply of high-pressure fluid power solutions. We continue to shape the future of the industry by working closely with customers to meet advancing needs.

Global Coverage and Aftermarket Support

Haskel, an international organization, offers world-wide service through a global network of factory trained authorized service and repair centers.

Quality

Our quality system is based on a commitment to customer satisfaction and continuous improvement. Global accreditations include ISO Management systems, ATEX, CE and more.

Technical Support

We offer extensive product and application knowledge to provide complete solutions, backed by our international network of highly trained distributors with thorough engineering experience.

Proven Technology

Our unrivaled 70-year reputation for safety, quality, performance and innovation is the foundation of all Haskel products.

TECHNICAL INFORMATION SHEET



CONTACT YOUR REP TO ORDER

GAS BOOSTER SYSTEM

From selection and design to manufacturing and installation, standard packages provide precision and performance for gas transfer, charging and storage applications. Our standard gas booster systems are available in single acting, double acting, and two stage models.

	System	Booster	Min Inlet (PSI)	Max Inlet (PSI)	Max Outlet Pressure	Max Outlet Pressure System Rating (PSI)
Single Acting	GBR-01-04495	AG-30	180	4495	30 Pa	4495
	GBR-12-09000	AG-62	365	4495	60 Pa	9000
	GBR-02-11250	AG-75	450	4495	75 Pa	11250
	GBR-08-20000	AG-152	800	4495	150 Pa	20000
Double Acting	GBR-04-02320	AGD-7	115	2320	7 Pa + Ps	2320
	GBR-05-09000	AGD-30	365	4495	30 Pa + Ps	9000
	GBR-06-09000	AGD-62	365	4495	60 Pa + Ps	9000
	GBR-07-15000	AGD-75	595	4495	75 Pa + Ps	15000
	GBR-08-20000	AGD-152	800	4495	150 Pa + Ps	20000
	System	Booster	Min Inlet (PSI)	Max Inlet Pressure Formula*	Max Outlet Stall Pressure Formula	Max Outlet Pressure System Rating (PSI)
Two Stage	GBR-09-05700	AGT-7/30	100	2 Pa	30 Pa + 4 Ps	5,700
	GBR-10-09000	AGT-15/30	180	15 Pa	30 Pa + 2 Ps	9,000
	GBR-11-13875	AGT-15/75	135	3.5 Pa	75 Pa + 5 Ps	13,875
	GBR-13-09000	AGT-14/62	120	4 Pa	60 Pa + 4 Ps	9,000
	GBR-14-09000	AGT-32/62	180	30 Pa	60 Pa + 2 Ps	9,000
	GBR-15-20000	AGT-62/152	335	40 Pa	150 Pa + 2.5 Ps	20,000

*For two stage gas boosters supply pressure is limited by factor x air drive (Pa) to avoid interstage stall.

Pa = Air drive pressure. (Min. air drive pressure 25 psi. Max air drive pressure 150 psi)

Ps = Gas inlet supply pressure

Overall Unit Dimensions

	Single & Double Acting	Two Stage
Width (mm)	1000	1000
Depth (mm)	400	400
Height (mm)	550	550
Weight (KG)	50	60

Connections—Single & Double Acting

Air Drive Connection: -1/2" BSPP (Female)

Inlet Gas Connection: -1/4" NPT (Female)

Outlet Gas Connection : -1/4" HP (Female)

AG-30 and AGD-7 models will be 1/4" NPT (Female)

Vent Gas Connection: -1/4" NPT (Female)

Connections—Two Stage

Air Drive Connection: -1/2" BSPP (Female)

Inlet Gas Connection: -1/4" NPT (Female)

Outlet Gas Connection: -1/4" HP (Female)

Vent Gas Connection: -1/4" NPT (Female)

SCOPE OF SUPPLY

- Haskel air driven gas booster with external pilot air modification to enable use of external air pilot switches to automatically start and stop the booster.
- Adjustable Haskel inlet air pilot switch used to stop the booster when the gas supply pressure falls below the adjusted minimum set point. (OPTIONAL)
- Adjustable Haskel remote set outlet air pilot switch used to stop the booster when the outlet pressure reaches the adjusted maximum set point. (OPTIONAL)
- Outlet pressure gauge, safe case design, 100mm diameter, panel mounted with bar / psi dual scale. Accuracy +/- 1% FSD.
- Inlet pressure gauge, safe case design, 100mm diameter, panel mounted with bar / psi dual scale. Accuracy +/- 1% FSD.
- Gas filter, 5 micron rated, used to stop any ingested contamination from entering the booster (e.g while changing out gas supply bottles).
- Roll bar frame (not shown) with sloping operator panel into which the booster and controls are mounted. The frame will be a brushed 316 stainless steel.
- Combined air inlet filter regulator, with integral pressure gauge and on/off control valve. Air filter – inline with 40 micron filtration to maintain air drive quality. Adjustable air regulator used to set the air drive pressure, adjustable between 0 – 150 PSI. 25mm air gauge indicates the regulated air pressure setting. Manual on/off valve and speed control valve, panel mounted, used to adjust the cycling speed at which the booster operates.
- Adjustable Haskel relief valve used to protect the booster and other components from over pressurization, piped to a common vent connection.
- Adjustable remote set air pilot regulator used to adjust the set point for the remote set outlet air pilot switch (item 3). (OPTIONAL)
- 25mm air gauge, panel mounted, used to indicate the adjustable remote set regulator adjusted pressure. (OPTIONAL)
- Manually operated Butech outlet isolation valve, panel mounted, piped to a common vent connection.
- Manually operated Butech outlet pressure vent valve, panel mounted, piped to a common vent connection.
- Interstage cooler: Single & Double Acting—Not supplied. Two Stage Gas Booster— a Haskel design integral tube and shell cooler used to reduce the boosted gas temperature.

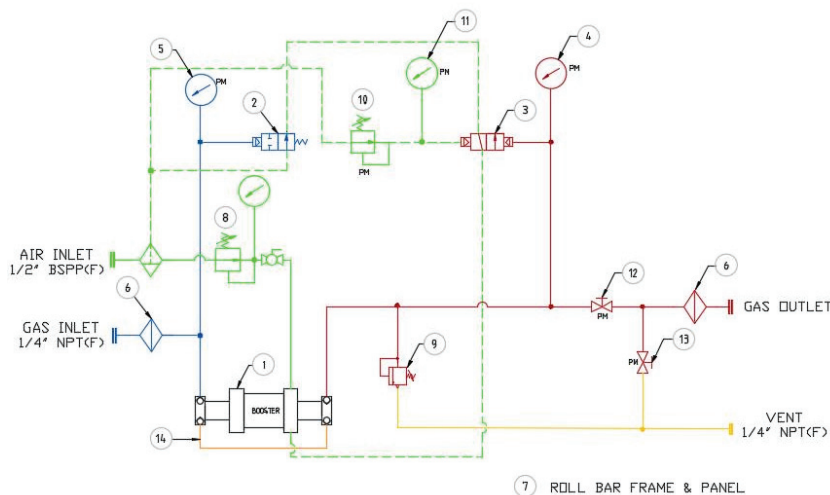

PART NUMBER ORDERS

Example Order Number: **GBR-01-04495-1-A-ST**

Booster Options		Max Operating Pressure (PSI)	Media (Inert Gases)	APS/Remoteset Option	Standard
GBR	- 01 AG-30	- 04495	- 1	- A Inlet & Outlet APS c/w remote set	- ST
	12 AG-62	09000	1	B Inlet APS only	ST
	02 AG-75	11250	1	C Outlet APS only	ST
	03 AG-152	20000	1	D No APS or remote set	ST
	04 AGD-7	02320	1	E Inlet & Outlet APS only	ST
	05 AGD-30	09000	1		ST
	06 AGD-62	09000	1		ST
	07 AGD-75	15000	1		ST
	08 AGD-152	20000	1		ST
	09 AGT-7/30	05700	1		ST
	10 AGT-15/30	09000	1		ST
	11 AGT-15/75	13875	1		ST
	13 AGT-14/62	09000	1		ST
	14 AGT-32/62	09000	1		ST
	15 AGT-62/152	20000	1		ST