

# 5" AIR-TO-CLOSE

Model ATC5

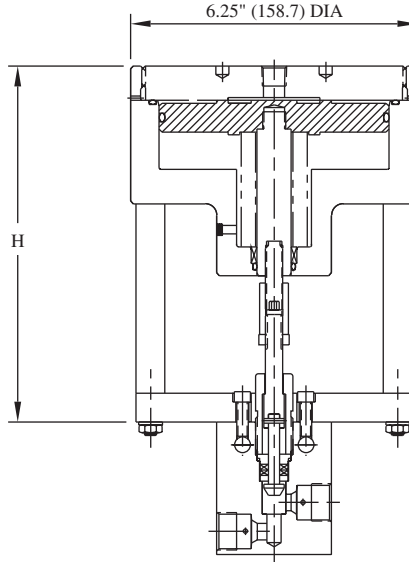

System Pressure - PSI (bar)

Valve Model	H	3,000 (210)	4,000 (280)	5,000 (340)	6,000 (410)	7,000 (480)	8,000 (550)	9,000 (620)	10,000 (690)	11,000 (760)	12,000 (830)
SLPV4	7.31" (185.7)	21 PSI 1.5 bar	24 PSI 1.7 bar	27 PSI 1.9 bar	30 PSI 2.1 bar	34 PSI 2.3 bar	37 PSI 2.6 bar	40 PSI 2.8 bar	43 PSI 3.0 bar	46 PSI 3.2 bar	49 PSI 3.4 bar
SLPV6											
SLPV8	7.75" (196.9)	26 PSI 1.8 bar	31 PSI 2.1 bar	36 PSI 2.5 bar	41 PSI 2.8 bar						

Valve Model	H	2,000 (140)	4,000 (280)	5,000 (340)	6,000 (410)	7,000 (480)	8,000 (550)	10,000 (690)	12,000 (830)	14,000 (970)	15,000 (1030)
DHP2	7.31" (185.7)	18 PSI	24 PSI	27 PSI	30 PSI	34 PSI	37 PSI	43 PSI	49 PSI	55 PSI	59 PSI
DHP4		1.2 bar	1.7 bar	1.9 bar	2.1 bar	2.3 bar	2.6 bar	3.0 bar	3.4 bar	3.8 bar	4.1 bar
DHP6											
DHP8											
SFPV2	7.31" (185.7)	18 PSI	24 PSI	27 PSI	30 PSI	34 PSI	37 PSI	43 PSI	49 PSI	55 PSI	59 PSI
SFPV4		1.2 bar	1.7 bar	1.9 bar	2.1 bar	2.3 bar	2.6 bar	3.0 bar	3.4 bar	3.8 bar	4.1 bar
SFPV6	7.75" (196.9)	21 PSI	31 PSI	36 PSI	41 PSI	46 PSI	51 PSI	61 PSI	70 PSI	80 PSI	85 PSI
SFPV8		1.5 bar	2.1 bar	2.5 bar	2.8 bar	3.2 bar	3.5 bar	4.2 bar	4.8 bar	5.5 bar	5.9 bar

Valve Model	H	2,000 (140)	4,000 (280)	6,000 (410)	8,000 (550)	10,000 (690)	12,000 (830)	14,000 (970)	16,000 (1100)	18,000 (1240)	20,000 (1380)
20UV4	7.31" (185.7)	18 PSI	24 PSI	30 PSI	37 PSI	43 PSI	49 PSI	55 PSI	62 PSI	68 PSI	74 PSI
20UV6		1.2 bar	1.7 bar	2.1 bar	2.6 bar	3.0 bar	3.4 bar	3.8 bar	4.3 bar	4.7 bar	5.1 bar
20UV9	7.75" (196.9)	21 PSI	31 PSI	41 PSI	51 PSI	61 PSI	70 PSI	80 PSI	90 PSI	100 PSI	
		1.5 bar	2.1 bar	2.8 bar	3.5 bar	4.2 bar	4.8 bar	5.5 bar	6.2 bar	6.9 bar	

Valve Model	H	15,000 (1030)	20,000 (1380)	25,000 (1720)	30,000 (2070)	35,000 (2410)	40,000 (2760)	45,000 (3100)	50,000 (3450)	55,000 (3790)	60,000 (4140)
30UV	7.31" (185.7)	23 PSI 1.6 bar	27 PSI 1.9 bar	31 PSI 2.1 bar	35 PSI 2.4 bar						
40UV	7.31" (185.7)	21 PSI 1.5 bar	24 PSI 1.7 bar	27 PSI 1.9 bar	30 PSI 2.1 bar	33 PSI 2.3 bar	36 PSI 2.5 bar				
60UV	7.31" (185.7)	15 PSI 1.0 bar	16 PSI 1.1 bar	17 PSI 1.2 bar	18 PSI 1.2 bar	19 PSI 1.3 bar	20 PSI 1.4 bar	21 PSI 1.5 bar	21 PSI 1.5 bar	22 PSI 1.5 bar	23 PSI 1.6 bar

Valve Model	H	60,000 (4140)	70,000 (4830)	80,000 (5520)	90,000 (6200)	100,000 (6890)	110,000 (7580)	120,000 (8270)	130,000 (8960)	140,000 (9650)	150,000 (10340)
150V	7.37" (187.2)	38 PSI 2.6 bar	42 PSI 2.9 bar	47 PSI 3.2 bar	51 PSI 3.5 bar	56 PSI 3.9 bar	60 PSI 4.1 bar	64 PSI 4.4 bar	69 PSI 4.8 bar	73 PSI 5.0 bar	78 PSI 5.4 bar

All dimensions are for reference only and are subject to change without notice.  
Dimensions in parentheses are millimeters (mm).

# 8" AIR-TO-CLOSE

Model ATC8

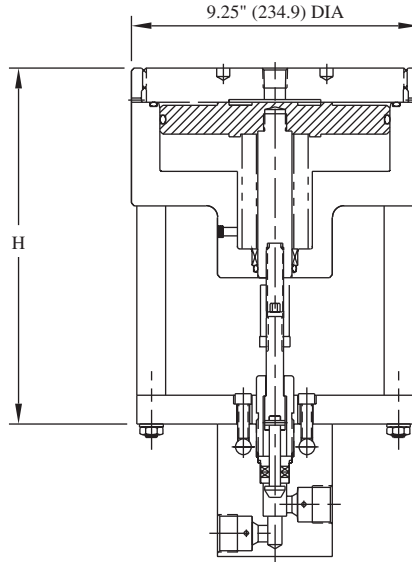

System Pressure - PSI (bar)

Valve Model	H	2,000 (140)	4,000 (280)	5,000 (340)	6,000 (410)	7,000 (480)	8,000 (550)	10,000 (690)	12,000 (830)	14,000 (970)	15,000 (1030)
DHP12	8.44" (214.4)	33 PSI 2.3 bar	55 PSI 3.8 bar	67 PSI 4.6 bar	78 PSI 5.4 bar	89 PSI 6.1 bar	100 PSI 6.9 bar				
SFPV6	7.88" (200.2)	15 PSI 1.0 bar	19 PSI 1.3 bar	21 PSI 1.5 bar	23 PSI 1.6 bar	24 PSI 1.7 bar	26 PSI 1.8 bar	30 PSI 2.1 bar	34 PSI 2.3 bar	38 PSI 2.6 bar	40 PSI 2.8 bar
FPV12	9.06" (230.1)	26 PSI 1.8 bar	41 PSI 2.8 bar	48 PSI 3.3 bar	56 PSI 3.9 bar	63 PSI 4.3 bar	70 PSI 4.8 bar	85 PSI 5.9 bar	100 PSI 6.9 bar		

Valve Model	H	2,000 (140)	4,000 (280)	6,000 (410)	8,000 (550)	10,000 (690)	12,000 (830)	14,000 (970)	16,000 (1100)	18,000 (1240)	20,000 (1380)
20UV9	8.00" (203.2)	15 PSI 1.0 bar	19 PSI 1.3 bar	23 PSI 1.6 bar	26 PSI 1.8 bar	30 PSI 2.1 bar	34 PSI 2.3 bar	38 PSI 2.6 bar	42 PSI 2.9 bar	45 PSI 3.1 bar	49 PSI 3.4 bar
20V12	8.00" (203.2)	20 PSI 1.4 bar	29 PSI 2.0 bar	38 PSI 2.6 bar	47 PSI 3.2 bar	56 PSI 3.9 bar	65 PSI 4.5 bar	74 PSI 5.1 bar	83 PSI 5.7 bar	92 PSI 6.3 bar	101 PSI 7.0 bar
20V16	9.06" (230.1)	26 PSI 1.8 bar	41 PSI 2.8 bar	56 PSI 3.9 bar	70 PSI 4.8 bar	85 PSI 5.9 bar	100 PSI 6.9 bar				

Valve Model	H	12,000 (830)	14,000 (970)	16,000 (1100)	18,000 (1240)	20,000 (1380)	22,000 (1520)	24,000 (1650)	26,000 (1790)	28,000 (1930)	30,000 (2070)
30V16	8.25" (209.6)	65 PSI 4.5 bar	74 PSI 5.1 bar	83 PSI 5.7 bar	92 PSI 6.3 bar						

Valve Model	H	60,000 (4140)	70,000 (4830)	80,000 (5520)	90,000 (6200)	100,000 (6890)	110,000 (7580)	120,000 (8270)	130,000 (8960)	140,000 (9650)	150,000 (10340)
150V	7.38" (187.5)	21 PSI 1.5 bar	23 PSI 1.6 bar	25 PSI 1.7 bar	27 PSI 1.9 bar	28 PSI 1.9 bar	30 PSI 2.1 bar	32 PSI 2.2 bar	33 PSI 2.3 bar	35 PSI 2.4 bar	37 PSI 2.6 bar

All dimensions are for reference only and are subject to change without notice.  
Dimensions in parentheses are millimeters (mm).



# 5" DOUBLE-PISTON AIR-TO-CLOSE

Model 2XATC5

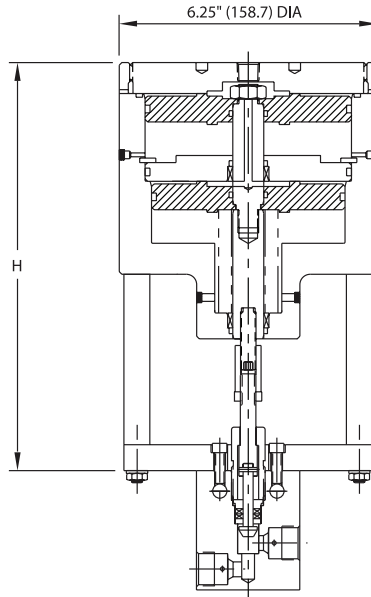

System Pressure - PSI (bar)

Valve Model	H	3,000 (210)	4,000 (280)	5,000 (340)	6,000 (410)	7,000 (480)	8,000 (550)	9,000 (620)	10,000 (690)	11,000 (760)	12,000 (830)
SLPV4	7.31" (185.7)	21 PSI 1.5 bar	24 PSI 1.7 bar	27 PSI 1.9 bar	30 PSI 2.1 bar	34 PSI 2.3 bar	37 PSI 2.6 bar	40 PSI 2.8 bar	43 PSI 3.0 bar	46 PSI 3.2 bar	49 PSI 3.4 bar
SLPV6											
SLPV8	7.75" (196.9)	26 PSI 1.8 bar	31 PSI 2.1 bar	36 PSI 2.5 bar	41 PSI 2.8 bar						

Valve Model	H	2,000 (140)	4,000 (280)	5,000 (340)	6,000 (410)	7,000 (480)	8,000 (550)	10,000 (690)	12,000 (830)	14,000 (970)	15,000 (1030)
DHP2	7.31" (185.7)	18 PSI	24 PSI	27 PSI	30 PSI	34 PSI	37 PSI	43 PSI	49 PSI	55 PSI	59 PSI
DHP4		1.2 bar	1.7 bar	1.9 bar	2.1 bar	2.3 bar	2.6 bar	3.0 bar	3.4 bar	3.8 bar	4.1 bar
DHP6											
DHP8											
SFPV2	7.31" (185.7)	18 PSI	24 PSI	27 PSI	30 PSI	34 PSI	37 PSI	43 PSI	49 PSI	55 PSI	59 PSI
SFPV4		1.2 bar	1.7 bar	1.9 bar	2.1 bar	2.3 bar	2.6 bar	3.0 bar	3.4 bar	3.8 bar	4.1 bar
SFPV6	7.75" (196.9)	21 PSI	31 PSI	36 PSI	41 PSI	46 PSI	51 PSI	61 PSI	70 PSI	80 PSI	85 PSI
SFPV8		1.5 bar	2.1 bar	2.5 bar	2.8 bar	3.2 bar	3.5 bar	4.2 bar	4.8 bar	5.5 bar	5.9 bar

Valve Model	H	2,000 (140)	4,000 (280)	6,000 (410)	8,000 (550)	10,000 (690)	12,000 (830)	14,000 (970)	16,000 (1100)	18,000 (1240)	20,000 (1380)
20UV4	7.31" (185.7)	18 PSI	24 PSI	30 PSI	37 PSI	43 PSI	49 PSI	55 PSI	62 PSI	68 PSI	74 PSI
20UV6		1.2 bar	1.7 bar	2.1 bar	2.6 bar	3.0 bar	3.4 bar	3.8 bar	4.3 bar	4.7 bar	5.1 bar
20UV9	7.75" (196.9)	21 PSI	31 PSI	41 PSI	51 PSI	61 PSI	70 PSI	80 PSI	90 PSI	100 PSI	
		1.5 bar	2.1 bar	2.8 bar	3.5 bar	4.2 bar	4.8 bar	5.5 bar	6.2 bar	6.9 bar	

Valve Model	H	15,000 (1030)	20,000 (1380)	25,000 (1720)	30,000 (2070)	35,000 (2410)	40,000 (2760)	45,000 (3100)	50,000 (3450)	55,000 (3790)	60,000 (4140)
30UV	7.31" (185.7)	23 PSI	27 PSI	31 PSI	35 PSI						
		1.6 bar	1.9 bar	2.1 bar	2.4 bar						
40UV	7.31" (185.7)	21 PSI	24 PSI	27 PSI	30 PSI	33 PSI	36 PSI				
		1.5 bar	1.7 bar	1.9 bar	2.1 bar	2.3 bar	2.5 bar				
60UV	7.31" (185.7)	15 PSI	16 PSI	17 PSI	18 PSI	19 PSI	20 PSI	21 PSI	21 PSI	22 PSI	23 PSI
		1.0 bar	1.1 bar	1.2 bar	1.2 bar	1.3 bar	1.4 bar	1.5 bar	1.5 bar	1.5 bar	1.6 bar

Valve Model	H	60,000 (4140)	70,000 (4830)	80,000 (5520)	90,000 (6200)	100,000 (6890)	110,000 (7580)	120,000 (8270)	130,000 (8960)	140,000 (9650)	150,000 (10340)
150V	7.37" (187.2)	38 PSI	42 PSI	47 PSI	51 PSI	56 PSI	60 PSI	64 PSI	69 PSI	73 PSI	78 PSI
		2.6 bar	2.9 bar	3.2 bar	3.5 bar	3.9 bar	4.1 bar	4.4 bar	4.8 bar	5.0 bar	5.4 bar

All dimensions are for reference only and are subject to change without notice.  
Dimensions in parentheses are millimeters (mm).

# 5" AIR-TO-OPEN

Model ATO5

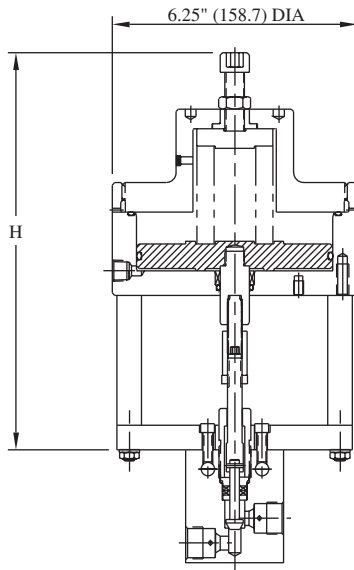

Valve Model	H		Spring Compression						
			1/8"	3/16"	1/4"	5/16"	3/8"	7/16"	1/2"
SLPV4 SLPV6	8.00" (203.2)	MAWP	8,500 586 bar	11,000 758 bar	11,500 793 bar				
		Required Air Pressure	76 PSI 5.2 bar	76 PSI 5.2 bar	82 PSI 5.7 bar				
SLPV8	8.00" (203.2)	MAWP	5,500 379 bar						
		Required Air Pressure	75 PSI 5.2 bar						
DHP2 DHP4 DHP6 DHP8	8.00" (203.2)	MAWP	8,500 586 bar	11,000 758 bar	13,000 896 bar	15,000 1034 bar			
		Required Air Pressure	76 PSI 5.2 bar	76 PSI 5.2 bar	79 PSI 5.5 bar	81 PSI 5.6 bar			
SFPV2 SFPV4	8.00" (203.2)	MAWP	8,500 586 bar	11,000 758 bar	13,000 896 bar	15,000 1034 bar			
		Required Air Pressure	76 PSI 5.2 bar	76 PSI 5.2 bar	79 PSI 5.5 bar	81 PSI 5.6 bar			
SFPV6 SFPV8	8.00" (203.2)	MAWP	5,500 379 bar	7,000 483 bar	8,500 586 bar	10,000 689 bar	11,000 758 bar	12,500 862 bar	14,000 965 bar
		Required Air Pressure	75 PSI 5.2 bar	77 PSI 5.3 bar	78 PSI 5.4 bar	79 PSI 5.5 bar	82 PSI 5.7 bar	83 PSI 5.7 bar	84 PSI 5.8 bar
20UV4 20UV6	8.00" (203.2)	MAWP	8,500 586 bar	11,000 758 bar	13,000 896 bar	15,500 1069 bar	17,500 1207 bar	20,000 1379 bar	
		Required Air Pressure	76 PSI 5.2 bar	76 PSI 5.2 bar	79 PSI 5.5 bar	79 PSI 5.5 bar	81 PSI 5.6 bar	82 PSI 5.7 bar	
20UV9	8.00" (203.2)	MAWP	5,500 379 bar	7,000 483 bar	8,500 586 bar	10,000 689 bar	11,000 758 bar	12,500 862 bar	14,000 965 bar
		Required Air Pressure	75 PSI 5.2 bar	77 PSI 5.3 bar	78 PSI 5.4 bar	79 PSI 5.5 bar	82 PSI 5.7 bar	83 PSI 5.7 bar	84 PSI 5.8 bar
30UV	8.00" (203.2)	MAWP	30,000 2068 bar						
		Required Air Pressure	78 PSI 5.4 bar						
40UV	8.00" (203.2)	MAWP	40,000 2758 bar						
		Required Air Pressure	78 PSI 5.4 bar						
60UV	8.00" (203.2)	MAWP	60,000 4136 bar						
		Required Air Pressure	88 PSI 6.1 bar						
150V	8.19" (208.0)	MAWP	60,000 4136 bar	75,000 5171 bar	95,000 6549 bar	100,000 6894 bar	125,000 8618 bar	140,000 9652 bar	150,000 10341 bar
		Required Air Pressure	76 PSI 5.2 bar	78 PSI 5.4 bar	78 PSI 5.4 bar	83 PSI 5.7 bar	81 PSI 5.6 bar	83 PSI 5.7 bar	86 PSI 5.9 bar

All dimensions are for reference only and are subject to change without notice.  
Dimensions in parentheses are millimeters (mm).

# 8" AIR-TO-OPEN

Model ATO8

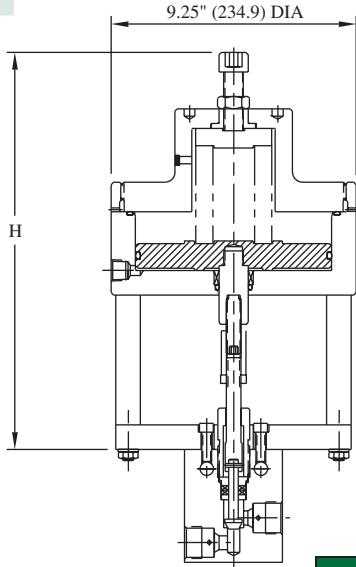

Valve Model	H		Spring Compression									
			1/8"	3/16"	1/4"	5/16"	3/8"	7/16"	1/2"	9/16"	5/8"	
DHP2 DHP4 DHP6 DHP8	8.50" (215.9)	MAWP	15,000 1034 bar									
Required Air Pressure		50 PSI 3.5 bar										
DHP12 DHP16	9.38" (238.3)	MAWP	1,500 103 bar	2,000 138 bar	2,000 138 bar	2,500 172 bar	3,000 207 bar	3,500 241 bar	4,000 276 bar	4,500 310 bar	5,000 345 bar	
Required Air Pressure		54 PSI 3.7 bar	55 PSI 3.8 bar	60 PSI 4.1 bar	61 PSI 4.2 bar	62 PSI 4.3 bar	63 PSI 4.3 bar	64 PSI 4.4 bar	65 PSI 4.5 bar	66 PSI 4.6 bar		
SFPV6 SFPV8	8.69" (220.7)	MAWP	9,500 655 bar	12,000 827 bar	14,500 1000 bar	15,000 1034 bar						
Required Air Pressure		50 PSI 3.5 bar	51 PSI 3.5 bar	52 PSI 3.6 bar	56 PSI 3.9 bar							
FPV12 FPV16	10.63" (270.0)	MAWP	2,500 172 bar	3,000 207 bar	3,500 241 bar	4,000 276 bar	5,000 345 bar	5,500 379 bar	6,000 414 bar	7,000 483 bar	7,500 517 bar	
Required Air Pressure		53 PSI 3.7 bar	55 PSI 3.8 bar	57 PSI 3.9 bar	60 PSI 4.1 bar	59 PSI 4.1 bar	62 PSI 4.3 bar	64 PSI 4.4 bar	64 PSI 4.4 bar	66 PSI 4.6 bar		
20UV4 20UV6	8.12" (206.2)	MAWP	15,000 1034 bar	19,000 1310 bar	20,000 1379 bar							
Required Air Pressure		50 PSI 3.5 bar	51 PSI 3.5 bar	55 PSI 3.8 bar								
20UV9	10.00" (254.0)	MAWP	9,500 655 bar	12,000 827 bar	14,500 1000 bar	17,000 1172 bar	19,500 1344 bar	20,000 1379 bar				
Required Air Pressure		50 PSI 3.5 bar	51 PSI 3.5 bar	52 PSI 3.6 bar	53 PSI 3.7 bar	54 PSI 3.7 bar	58 PSI 4.0 bar					
20V12	8.50" (215.9)	MAWP	4,000 276 bar	5,000 345 bar	6,000 414 bar	7,000 483 bar	8,000 552 bar	9,500 655 bar	10,500 724 bar	11,500 793 bar	12,500 862 bar	
Required Air Pressure		53 PSI 3.7 bar	55 PSI 3.8 bar	57 PSI 3.9 bar	58 PSI 4.0 bar	60 PSI 4.1 bar	62 PSI 4.3 bar	64 PSI 4.4 bar	64 PSI 4.4 bar	66 PSI 4.6 bar		
20V16	10.50" (266.7)	MAWP	2,500 172 bar	3,000 207 bar	3,500 241 bar	4,000 276 bar	5,000 345 bar	5,500 379 bar	6,000 414 bar	7,000 483 bar	7,500 517 bar	
Required Air Pressure		53 PSI 3.7 bar	55 PSI 3.8 bar	57 PSI 3.9 bar	60 PSI 4.1 bar	59 PSI 4.1 bar	62 PSI 4.3 bar	64 PSI 4.4 bar	64 PSI 4.4 bar	66 PSI 4.6 bar		
30V16	9.03" (229.4)	MAWP	4,000 276 bar	5,000 345 bar	6,000 414 bar	7,000 483 bar	8,000 552 bar	9,500 655 bar	10,500 724 bar	11,500 793 bar	12,500 862 bar	
Required Air Pressure		53 PSI 3.7 bar	55 PSI 3.8 bar	57 PSI 3.9 bar	58 PSI 4.0 bar	60 PSI 4.1 bar	60 PSI 4.1 bar	62 PSI 4.3 bar	64 PSI 4.4 bar	66 PSI 4.6 bar		
150V	9.19" (233.4)	MAWP	110,000 7583 bar	135,000 9307 bar	150,000 10341 bar							
Required Air Pressure		50 PSI 3.5 bar	51 PSI 3.5 bar	54 PSI 3.7 bar								

All dimensions are for reference only and are subject to change without notice.  
Dimensions in parentheses are millimeters (mm).



# 5" DOUBLE-PISTON AIR-TO-OPEN

Model 2XATO5

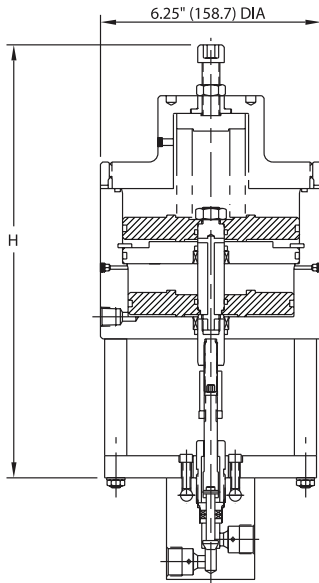

Valve Model	H		Spring Compression						
			1/8"	3/16"	1/4"	5/16"	3/8"	7/16"	1/2"
SLPV4 SLPV6	8.00" (203.2)	MAWP	8,500 586 bar	11,000 758 bar	11,500 793 bar				
		Required Air Pressure	76 PSI 5.2 bar	76 PSI 5.2 bar	82 PSI 5.7 bar				
SLPV8	8.00" (203.2)	MAWP	5,500 379 bar						
		Required Air Pressure	75 PSI 5.2 bar						
DHP2 DHP4 DHP6 DHP8	8.00" (203.2)	MAWP	8,500 586 bar	11,000 758 bar	13,000 896 bar	15,000 1034 bar			
		Required Air Pressure	76 PSI 5.2 bar	76 PSI 5.2 bar	79 PSI 5.5 bar	81 PSI 5.6 bar			
SFPV2 SFPV4	8.00" (203.2)	MAWP	8,500 586 bar	11,000 758 bar	13,000 896 bar	15,000 1034 bar			
		Required Air Pressure	76 PSI 5.2 bar	76 PSI 5.2 bar	79 PSI 5.5 bar	81 PSI 5.6 bar			
SFPV6 SFPV8	8.00" (203.2)	MAWP	5,500 379 bar	7,000 483 bar	8,500 586 bar	10,000 689 bar	11,000 758 bar	12,500 862 bar	14,000 965 bar
		Required Air Pressure	75 PSI 5.2 bar	77 PSI 5.3 bar	78 PSI 5.4 bar	79 PSI 5.5 bar	82 PSI 5.7 bar	83 PSI 5.7 bar	84 PSI 5.8 bar
20UV4 20UV6	8.00" (203.2)	MAWP	8,500 586 bar	11,000 758 bar	13,000 896 bar	15,500 1069 bar	17,500 1207 bar	20,000 1379 bar	
		Required Air Pressure	76 PSI 5.2 bar	76 PSI 5.2 bar	79 PSI 5.5 bar	79 PSI 5.5 bar	81 PSI 5.6 bar	82 PSI 5.7 bar	
20UV9	8.00" (203.2)	MAWP	5,500 379 bar	7,000 483 bar	8,500 586 bar	10,000 689 bar	11,000 758 bar	12,500 862 bar	14,000 965 bar
		Required Air Pressure	75 PSI 5.2 bar	77 PSI 5.3 bar	78 PSI 5.4 bar	79 PSI 5.5 bar	82 PSI 5.7 bar	83 PSI 5.7 bar	84 PSI 5.8 bar
30UV	8.00" (203.2)	MAWP	30,000 2068 bar						
		Required Air Pressure	78 PSI 5.4 bar						
40UV	8.00" (203.2)	MAWP	40,000 2758 bar						
		Required Air Pressure	78 PSI 5.4 bar						
60UV	8.00" (203.2)	MAWP	60,000 4136 bar						
		Required Air Pressure	88 PSI 6.1 bar						
150V	8.19" (208.0)	MAWP	60,000 4136 bar	75,000 5171 bar	95,000 6549 bar	100,000 6894 bar	125,000 8618 bar	140,000 9652 bar	150,000 10341 bar
		Required Air Pressure	76 PSI 5.2 bar	78 PSI 5.4 bar	78 PSI 5.4 bar	83 PSI 5.7 bar	81 PSI 5.6 bar	83 PSI 5.7 bar	86 PSI 5.9 bar

All dimensions are for reference only and are subject to change without notice.  
Dimensions in parentheses are millimeters (mm).



# 5" DOUBLE-ACTING

Model DA5

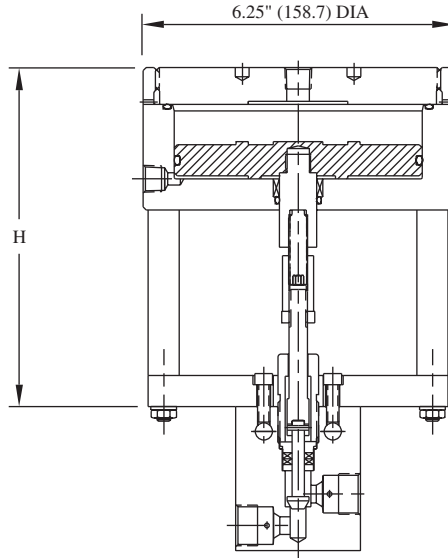

System Pressure - PSI (bar)

Valve Model	H	3,000 (210)	4,000 (280)	5,000 (340)	6,000 (410)	7,000 (480)	8,000 (550)	9,000 (620)	10,000 (690)	11,000 (760)	12,000 (830)
SLPV4	6.13" (155.7)	9 PSI 0.6 bar	13 PSI 0.9 bar	16 PSI 1.1 bar	19 PSI 1.3 bar	22 PSI 1.5 bar	25 PSI 1.7 bar	28 PSI 1.9 bar	31 PSI 2.1 bar	34 PSI 2.3 bar	38 PSI 2.6 bar
SLPV6	6.88" (174.8)	15 PSI 1.0 bar	20 PSI 1.4 bar	24 PSI 1.7 bar	29 PSI 2.0 bar						

Valve Model	H	2,000 (140)	4,000 (280)	5,000 (340)	6,000 (410)	7,000 (480)	8,000 (550)	10,000 (690)	12,000 (830)	14,000 (970)	15,000 (1030)
DHP2	6.38" (162.1)	6 PSI 0.4 bar	13 PSI 0.9 bar	16 PSI 1.1 bar	19 PSI 1.3 bar	22 PSI 1.5 bar	25 PSI 1.7 bar	31 PSI 2.1 bar	38 PSI 2.6 bar	44 PSI 3.0 bar	47 PSI 3.2 bar
DHP4											
DHP6											
DHP8											
SFPV2	6.12" (155.4)	6 PSI 0.4 bar	13 PSI 0.9 bar	16 PSI 1.1 bar	19 PSI 1.3 bar	22 PSI 1.5 bar	25 PSI 1.7 bar	31 PSI 2.1 bar	38 PSI 2.6 bar	44 PSI 3.0 bar	47 PSI 3.2 bar
SFPV4											
SFPV6											
SFPV8											

Valve Model	H	2,000 (140)	4,000 (280)	6,000 (410)	8,000 (550)	10,000 (690)	12,000 (830)	14,000 (970)	16,000 (1100)	18,000 (1240)	20,000 (1380)
20UV4	6.12" (155.4)	6 PSI 0.4 bar	13 PSI 0.9 bar	19 PSI 1.3 bar	25 PSI 1.7 bar	31 PSI 2.1 bar	38 PSI 2.6 bar	44 PSI 3.0 bar	50 PSI 3.5 bar	56 PSI 3.9 bar	63 PSI 4.3 bar
20UV6											
20UV9	6.12" (155.4)	10 PSI 0.7 bar	20 PSI 1.4 bar	29 PSI 2.0 bar	39 PSI 2.7 bar	49 PSI 3.4 bar	59 PSI 4.1 bar	68 PSI 4.7 bar	78 PSI 5.4 bar	88 PSI 6.1 bar	98 PSI 6.8 bar

Valve Model	H	15,000 (1030)	20,000 (1380)	25,000 (1720)	30,000 (2070)	35,000 (2410)	40,000 (2760)	45,000 (3100)	50,000 (3450)	55,000 (3790)	60,000 (4140)
30UV	7.25" (184.2)	12 PSI 0.8 bar	16 PSI 1.1 bar	20 PSI 1.4 bar	23 PSI 1.6 bar						
40UV	6.12" (155.4)	9 PSI 0.6 bar	12 PSI 0.8 bar	15 PSI 1.0 bar	18 PSI 1.2 bar	21 PSI 1.5 bar	24 PSI 1.7 bar				
60UV	6.12" (155.4)	3 PSI 0.2 bar	4 PSI 0.3 bar	5 PSI 0.3 bar	6 PSI 0.4 bar	7 PSI 0.5 bar	8 PSI 0.6 bar	9 PSI 0.6 bar	10 PSI 0.7 bar	11 PSI 0.8 bar	12 PSI 0.8 bar

Valve Model	H	60,000 (4140)	70,000 (4830)	80,000 (5520)	90,000 (6200)	100,000 (6890)	110,000 (7580)	120,000 (8270)	130,000 (8960)	140,000 (9650)	150,000 (10340)
150V	6.31" (160.3)	26 PSI 1.8 bar	31 PSI 2.1 bar	35 PSI 2.4 bar	40 PSI 2.8 bar	44 PSI 3.0 bar	48 PSI 3.3 bar	53 PSI 3.7 bar	57 PSI 3.9 bar	62 PSI 4.3 bar	66 PSI 4.6 bar

All dimensions are for reference only and are subject to change without notice.  
Dimensions in parentheses are millimeters (mm).

# 8" DOUBLE-ACTING

Model DA8

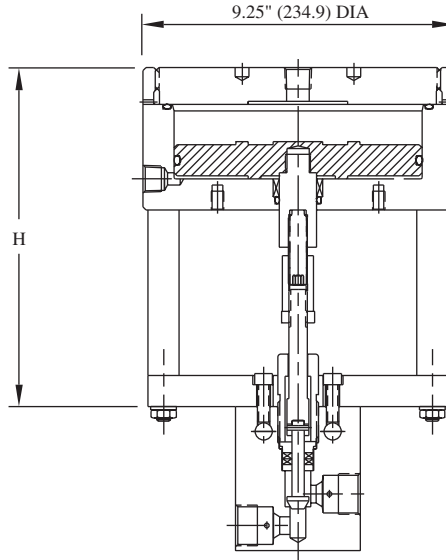

System Pressure - PSI (bar)

Valve Model	H	2,000 (140)	4,000 (280)	5,000 (340)	6,000 (410)	7,000 (480)	8,000 (550)	9,000 (620)	10,000 (690)	12,000 (830)	13,000 (900)
DHP12	7.38" (187.5)	22 PSI 1.5 bar	44 PSI 3.0 bar	55 PSI 3.8 bar	66 PSI 4.6 bar	78 PSI 5.4 bar	89 PSI 6.1 bar	100 PSI 6.9 bar			
DHP16											
FPV12	7.25" (184.2)	15 PSI 1.0 bar	30 PSI 2.1 bar	37 PSI 2.6 bar	44 PSI 3.0 bar	52 PSI 3.6 bar	59 PSI 4.1 bar	67 PSI 4.6 bar	74 PSI 5.1 bar	89 PSI 6.1 bar	96 PSI 6.6 bar
FPV16											

Valve Model	H	2,000 (140)	4,000 (280)	6,000 (410)	8,000 (550)	10,000 (690)	12,000 (830)	14,000 (970)	16,000 (1100)	18,000 (1240)	20,000 (1380)
20V12	6.62" (168.1)	9 PSI 0.6 bar	18 PSI 1.2 bar	27 PSI 1.9 bar	36 PSI 2.5 bar	45 PSI 3.1 bar	54 PSI 3.7 bar	63 PSI 4.3 bar	72 PSI 5.0 bar	81 PSI 5.6 bar	90 PSI 6.2 bar
20V16	7.25" (184.2)	15 PSI 1.0 bar	30 PSI 2.1 bar	44 PSI 3.0 bar	59 PSI 4.1 bar	74 PSI 5.1 bar	89 PSI 6.1 bar				

Valve Model	H	8,000 (550)	10,000 (690)	12,000 (830)	16,000 (1100)	18,000 (1240)	20,000 (1380)	22,000 (1520)	26,000 (1790)	28,000 (1930)	30,000 (2070)
30V16	7.25" (184.2)	36 PSI 2.5 bar	45 PSI 3.1 bar	54 PSI 3.7 bar	72 PSI 5.0 bar	81 PSI 5.6 bar	90 PSI 6.2 bar	99 PSI 6.8 bar			

All dimensions are for reference only and are subject to change without notice.  
Dimensions in parentheses are millimeters (mm).





# 5" DOUBLE-PISTON DOUBLE-ACTING

Model 2XDA5

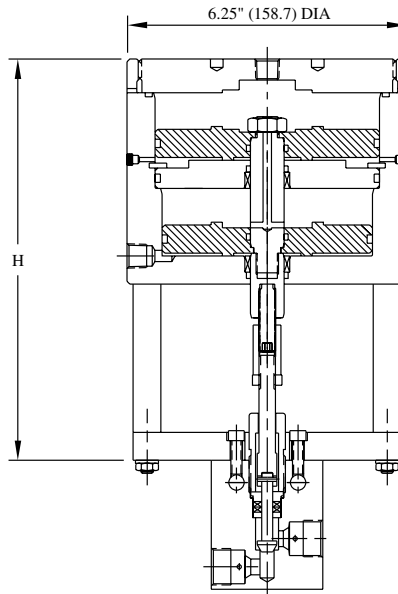

System Pressure - PSI (bar)

Valve Model	H	3,000 (210)	4,000 (280)	5,000 (340)	6,000 (410)	7,000 (480)	8,000 (550)	9,000 (620)	10,000 (690)	11,000 (760)	12,000 (830)
SLPV4	6.13" (155.7)	9 PSI 0.6 bar	13 PSI 0.9 bar	16 PSI 1.1 bar	19 PSI 1.3 bar	22 PSI 1.5 bar	25 PSI 1.7 bar	28 PSI 1.9 bar	31 PSI 2.1 bar	34 PSI 2.3 bar	38 PSI 2.6 bar
SLPV6	6.13" (155.7)										
SLPV8	6.88" (174.8)	15 PSI 1.0 bar	20 PSI 1.4 bar	24 PSI 1.7 bar	29 PSI 2.0 bar						

Valve Model	H	2,000 (140)	4,000 (280)	5,000 (340)	6,000 (410)	7,000 (480)	8,000 (550)	10,000 (690)	12,000 (830)	14,000 (970)	15,000 (1030)
DHP2	6.38" (162.1)	6 PSI 0.4 bar	13 PSI 0.9 bar	16 PSI 1.1 bar	19 PSI 1.3 bar	22 PSI 1.5 bar	25 PSI 1.7 bar	31 PSI 2.1 bar	38 PSI 2.6 bar	44 PSI 3.0 bar	47 PSI 3.2 bar
DHP4											
DHP6											
DHP8											
SFPV2	6.12" (155.4)	6 PSI 0.4 bar	13 PSI 0.9 bar	16 PSI 1.1 bar	19 PSI 1.3 bar	22 PSI 1.5 bar	25 PSI 1.7 bar	31 PSI 2.1 bar	38 PSI 2.6 bar	44 PSI 3.0 bar	47 PSI 3.2 bar
SFPV4	6.12" (155.4)										
SFPV6	6.12" (155.4)	10 PSI 0.7 bar	20 PSI 1.4 bar	24 PSI 1.7 bar	29 PSI 2.0 bar	34 PSI 2.3 bar	39 PSI 2.7 bar	49 PSI 3.4 bar	59 PSI 4.1 bar	68 PSI 4.7 bar	73 PSI 5.0 bar
SFPV8	6.12" (155.4)										

Valve Model	H	2,000 (140)	4,000 (280)	6,000 (410)	8,000 (550)	10,000 (690)	12,000 (830)	14,000 (970)	16,000 (1100)	18,000 (1240)	20,000 (1380)
20UV4	6.12" (155.4)	6 PSI 0.4 bar	13 PSI 0.9 bar	19 PSI 1.3 bar	25 PSI 1.7 bar	31 PSI 2.1 bar	38 PSI 2.6 bar	44 PSI 3.0 bar	50 PSI 3.5 bar	56 PSI 3.9 bar	63 PSI 4.3 bar
20UV6	6.12" (155.4)										
20UV9	6.12" (155.4)	10 PSI 0.7 bar	20 PSI 1.4 bar	29 PSI 2.0 bar	39 PSI 2.7 bar	49 PSI 3.4 bar	59 PSI 4.1 bar	68 PSI 4.7 bar	78 PSI 5.4 bar	88 PSI 6.1 bar	98 PSI 6.8 bar

Valve Model	H	15,000 (1030)	20,000 (1380)	25,000 (1720)	30,000 (2070)	35,000 (2410)	40,000 (2760)	45,000 (3100)	50,000 (3450)	55,000 (3790)	60,000 (4140)
30UV	7.25" (184.2)	12 PSI 0.8 bar	16 PSI 1.1 bar	20 PSI 1.4 bar	23 PSI 1.6 bar						
40UV	6.12" (155.4)	9 PSI 0.6 bar	12 PSI 0.8 bar	15 PSI 1.0 bar	18 PSI 1.2 bar	21 PSI 1.5 bar	24 PSI 1.7 bar				
60UV	6.12" (155.4)	3 PSI 0.2 bar	4 PSI 0.3 bar	5 PSI 0.3 bar	6 PSI 0.4 bar	7 PSI 0.5 bar	8 PSI 0.6 bar	9 PSI 0.6 bar	10 PSI 0.7 bar	11 PSI 0.8 bar	12 PSI 0.8 bar

Valve Model	H	60,000 (4140)	70,000 (4830)	80,000 (5520)	90,000 (6200)	100,000 (6890)	110,000 (7580)	120,000 (8270)	130,000 (8960)	140,000 (9650)	150,000 (10340)
150V	6.31" (160.3)	26 PSI 1.8 bar	31 PSI 2.1 bar	35 PSI 2.4 bar	40 PSI 2.8 bar	44 PSI 3.0 bar	48 PSI 3.3 bar	53 PSI 3.7 bar	57 PSI 3.9 bar	62 PSI 4.3 bar	66 PSI 4.6 bar

All dimensions are for reference only and are subject to change without notice.  
Dimensions in parentheses are millimeters (mm).

