



FULL TANK

HDPE WATER TANK

CLOSED TOP SERIES



FEATURES AND ADVANTAGES

- ★ Food grade material
- ★ High Chemical resistant
- ★ Non-toxic, odorless and corrosion free
- ★ Zero maintenance & highly durable
- ★ Light weight, strong, UV protection
- ★ Seamless construction, stress-free and leak proof

Certificated & Approved by:

SPAN[®]

Suruhanjaya Perkhidmatan Air Negara



MALAYSIA
MS1225 PART 1:2007



BUATAN MALAYSIAN
MADE IN MALAYSIA



HDPE CLOSED TOP TANK MODEL

MODEL	EXTERNAL DIMENSION MM (INCHES)		CAPACITY (GALLONS)		CAPACITY (LITERS)	
	DIAMETER	HEIGHT	EFFECTIVE	NOMINAL	EFFECTIVE	NOMINAL
N400	1500(59)	1350(53)	450	530	2043	2406
N500	1500(59)	1650(65)	550	650	2497	2951
N600	1500(59)	1900(75)	650	740	2951	3360
N800	1600(63)	2185(86)	860	950	3904	4313
N900	1600(63)	2413(95)	970	1060	4404	4812
N1000	1600(63)	2620(103)	1080	1170	4903	5312
N1000A	2440(96)	1250(49)	1080	1290	4903	5857
N1000B	1905(75)	1800(71)	1000	1040	4540	4722
N1250A	1905(75)	2110(83)	1280	1320	5811	5993
N1500	2440(96)	1650(65)	1500	1610	6810	7309
N1500A	1905(75)	2620(103)	1500	1630	6810	7400
N2000	2440(96)	2210(87)	2070	2380	9398	10805
N2500	2440(96)	2650(104)	2550	2640	11577	11986
N3000	2440(96)	3200(126)	3090	3300	14029	14982
N3500	2440(96)	3510(138)	3500	3620	15890	16435
N4000	2800(110)	3639(143)	4190	4410	19023	20021
N5000	2800(110)	4377(172)	5150	5430	23381	24652
N6000	2800(110)	4620(182)	6000	6300	27240	28602
N7000	2800(110)	5461(215)	7000	7410	31780	33641
N8000	3300(130)	4986(196)	8240	9370	37410	42540
N10000	3300(130)	6048(238)	10030	11400	45536	51756

WARRANTY:

1. Full Tank has a warranty period of 10 years for indoor use and 5 years for outdoor use.
2. All Drain, Balancing & Outlet piping connection, Strictly to be assembly with Flexible Joint (Refer to Handling & Installation Guidance).
3. Verification through KUNYI authorised distributors / dealer's chop in Malaysia with our serial number written, delivery order and invoice must be shown.
4. We shall not be held responsible for any defects or damage to the tank if the Installation Guidance are not adhered to
5. This warranty does not cover damages done during installation, misuse, negligence, rough handling or accident in your project site.
6. Our liability is limited to repair or replace (without installation) of the defective tank due to manufacturer's defect.
7. Should be effective and enforceable by the purchaser only upon receipt of full payment for the product(s) purchased.
8. Fitting / Accessories / Parts provided are not covered or applicable in our warranty.

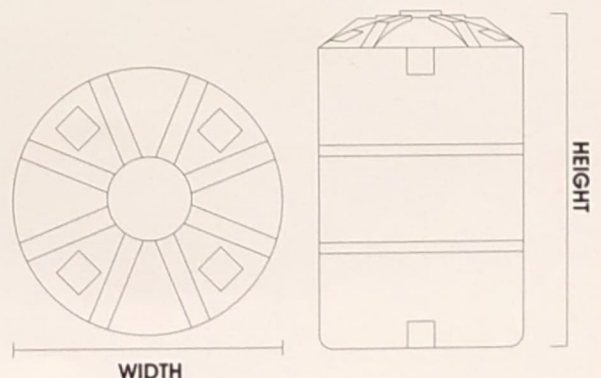

Dimensions and capacities of products are approximate due to manufacturing process.

KUNYI reserves the right to change or update,

- without notice any information contained in this catalogue.
- to change without notice the design, construction, materials, processing, or specification of the products; and to discontinue or limit production or distribution of any products.

Distributor by:





FULL TANK

PE WATER TANK



FEATURES & ADVANTAGES

WARRANTY TERMS & CONDITIONS

1. Full Tank has a warranty period of 10 years for indoor use and 5 years for outdoor use.
2. Full Tank is to be used for storing cold water at a stationary position only.
3. Our liability is strictly limited to the replacement of water tank only.
4. Warranty period is applicable on a prorated basic against manufacturer defects only. Manufacturer will not be liable for any consequent losses, defects or damages as a result of improper use or incorrect installation.

- ★ Food grade material
- ★ High chemical resistant
- ★ Non-toxic, odourless and corrosion free
- ★ Zero maintenance & highly durable
- ★ Light weight, strong, UV Protection
- ★ Seamless construction, stress-free and leak proof

Certificated & Approved by



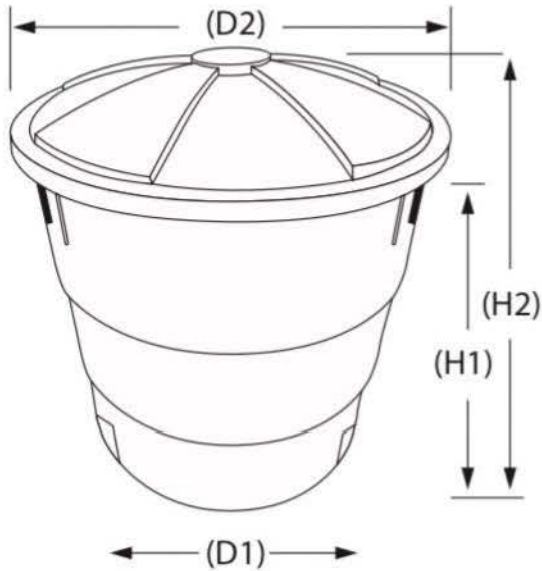

ROUND SERIES TANK *INTERNAL COVER

Model	CAPACITY (GALLONS)		EXTERNAL DIMENSION MM (INCHES)			
	EFFECTIVE	NOMINAL	DIAMETER TOP (D2)	DIAMETER BASE (D1)	HEIGHT w/o COVER (H1)	HEIGHT c/w COVER (H2)
N70/100-CA	70	100	1067 (42)	889 (35)	533 (21)	635 (25)
N100/150-CA	100	150	1143 (45)	914 (36)	610 (24)	711 (28)
N100/150-CAA	100	150	1016 (40)	762 (30)	940 (37)	1041 (41)
N150/200-CA	150	200	1270 (50)	991 (39)	686 (27)	838 (33)
N150/200-CAA	150	200	1295 (51)	940 (37)	914 (36)	1041 (41)
N200/250-CA	200	250	1397 (55)	1118 (44)	737 (29)	864 (34)
N200/250-CAA	200	250	1295 (51)	940 (37)	1067 (42)	1194 (47)
N250/300-CA	250	300	1473 (58)	1194 (47)	864 (34)	965 (38)
N250/300-CAA	250	300	1295 (51)	838 (33)	1219 (48)	1346 (53)
N300/350-CA	300	350	1575 (62)	1245 (49)	864 (34)	991 (39)
N300/350-CAA	300	350	1372 (54)	940 (37)	1397 (55)	1550 (61)
N350/400-CA	350	400	1575 (62)	1219 (48)	965 (38)	1143 (45)
N300/400-CAA	300	400	1245 (49)	991 (39)	1473 (58)	1600 (63)
N330/430-CA	330	430	1499 (59)	1118 (44)	1219 (48)	1372 (54)
N350/450-CA	350	450	1549 (61)	1143 (45)	1245 (49)	1397 (55)
N400/500-CA	400	500	1600 (63)	1194 (47)	1346 (53)	1499 (59)
N500/600-CA	500	600	1778 (70)	1372 (54)	1245 (49)	1397 (55)

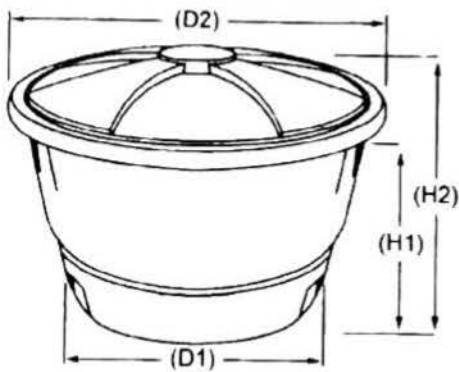

ROUND SERIES TANK *EXTERNAL COVER

Model	CAPACITY (GALLONS)		EXTERNAL DIMENSION MM (INCHES)			
	EFFECTIVE	NOMINAL	DIAMETER TOP (D2)	DIAMETER BASE (D1)	HEIGHT w/o COVER (H1)	HEIGHT c/w COVER (H2)
N50R	50	80	1016 (40)	838 (33)	508 (20)	608 (24)
N70R	70	100	1041 (41)	838 (33)	635 (25)	735 (29)
N100R	100	150	1143 (45)	890 (35)	711 (28)	836 (33)
N150R	150	200	1345 (53)	1092 (43)	736 (29)	864 (34)
N200R	200	250	1448 (57)	1195 (47)	790 (31)	915 (36)
N250R	250	300	1500 (59)	1220 (48)	912 (36)	1042 (41)
N300R	300	350	1475 (58)	1161 (46)	1206 (48)	1346 (53)
N350R	350	400	1525 (60)	1202 (47)	1270 (50)	1400 (55)
N400R	400	500	1728 (68)	1373 (54)	1193 (47)	1418 (56)
N500R	500	600	1700 (67)	1260 (50)	1500 (59)	1670 (66)

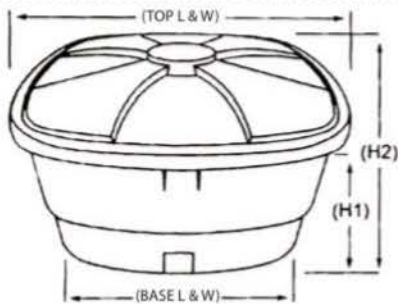

SQUARE SERIES TANK *EXTERNAL COVER

Model	CAPACITY (GALLONS)		EXTERNAL DIMENSION MM (INCHES)			
	EFFECTIVE	NOMINAL	TOP L & W	BASE L & W	HEIGHT w/o COVER (H1)	HEIGHT c/w COVER (H2)
N70/100-SA	70	100	1067 (42)	864 (34)	533 (21)	584 (23)
N100/150-SA	100	150	1118 (44)	940 (37)	584 (23)	660 (26)
N150/200-SA	150	200	1245 (49)	991 (39)	635 (25)	711 (28)
N200/250-SA	200	250	1397 (55)	1168 (46)	660 (26)	762 (30)

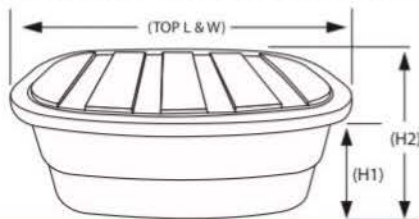

RECTANGULAR SERIES TANK *EXTERNAL COVER

Model	CAPACITY (GALLONS)		EXTERNAL DIMENSION MM (INCHES)			
	EFFECTIVE	NOMINAL	TOP L & W	BASE L & W	HEIGHT w/o COVER (H1)	HEIGHT c/w COVER (H2)
N150/200-RA	150	200	60 x 39	52 x 31	22	24

- All the dimensions & capacity are rounded off to the nearest mm (inch) and gallons.
- Kunyi reserve the right to alter the specification and price without prior notice.
- Kindly refer to our price lists for selection model, dimension & capacity.



Distributor by: