

# Precision Step Units type SRA

Data sheet

5-2000

## Application

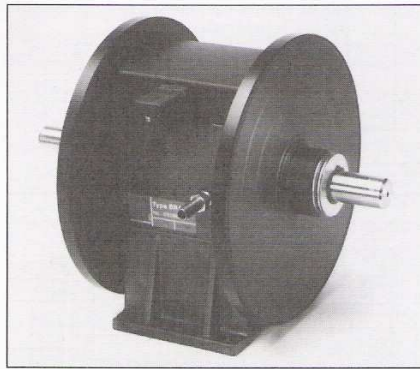

The Laurence Scott & Electromotors Ltd Precision Step Unit type SRA is the ideal solution for fast and accurate shaft motion in production machinery.

The SRA is especially advantageous in applications where the following is required:

- high production output
- high automation
- high precision and uniformity in machine operations
- great reliability
- low service costs

Typical applications are:

Labelling, dosing, cutting, packaging, label printing, box folding, thermoforming, sorting, stamping.

## Typical System construction

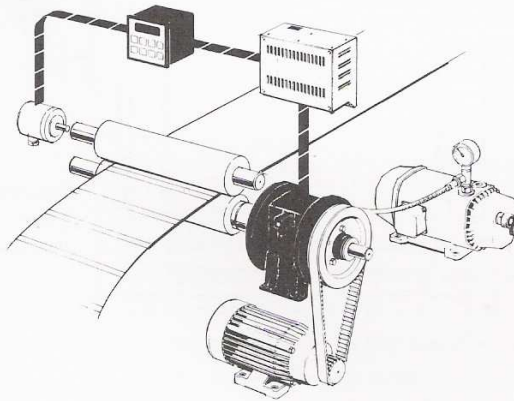

Fig. 1

The SRA Unit is part of the Laurence Scott & Electromotors Precision Step System which comprises:

- SRA mechanical unit
- SRB electronic control unit
- SRC signal sources
- SRD vacuum pump

Fig.1 shows the Precision Step System used for start-stop motion of the feeding rollers. The SRA step unit, the fundamental principle of the system, starts and stops the feeding rollers, and shafts extremely fast and precise (at low load operation a max. cycling frequency of 1200 to 3600 cycles/min can be obtained).

External signal sources (proximity transducers, photocells, encoders) give start and/or stop signals to electronic control units.

These are flexible control units, adapted for various functions e.g. pulse counting, signal suppression, compensation of external influences etc. Complex control functions are made practicable through software.

Function description

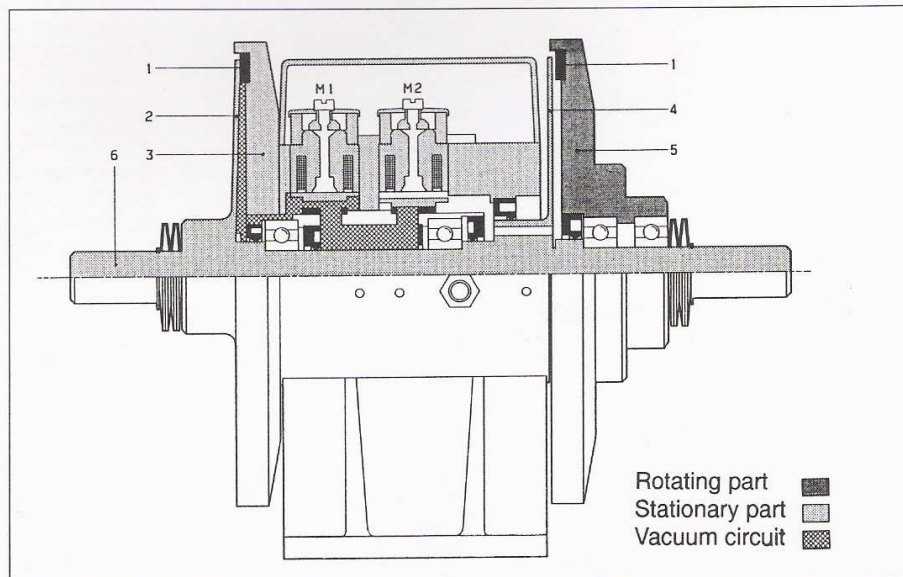
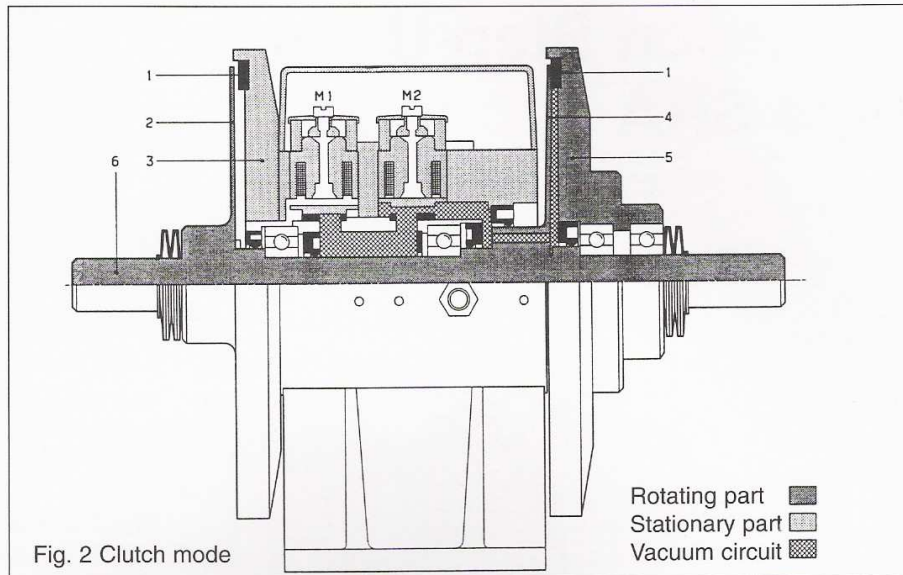

- 1. Friction ring
- 2. Brake disc
- 3. Housing
- 4. Clutch disc
- 5. Input flange
- 6. Solid output through shaft
- M<sub>1</sub> Solenoid valve, brake side
- M<sub>2</sub> Solenoid valve, clutch side

**Function description**

The SRA unit is operated by vacuum. Optimum performance is obtained at a vacuum of  $\Delta p$  0.7 bar.

The two solenoid valves of the SRA unit.  $M_1$  and  $M_2$  direct the vacuum to the clutch and brake side respectively.

When both solenoid valves are de-energised, normal pressure prevails allowing the through-going output shaft to rotate freely.

When solenoid valve  $M_2$  is energised, vacuum is generated between the input flange (pos. 5) and the clutch disc (pos. 4). The disc is sucked against the friction ring and the output shaft starts revolving.

The SRA is now in clutch mode, see fig. 2.

When solenoid valve  $M_1$  is energised and solenoid valve  $M_2$  is de-energised, vacuum is generated, and the brake disc (pos. 2) is sucked against the friction ring of the housing (pos. 3). The input flange rotates freely, as normal pressure prevails again. The output shaft is decelerated until standstill and is locked in this position with a holding torque.

The SRA is now in brake mode, see fig. 3.

**SRA timing**

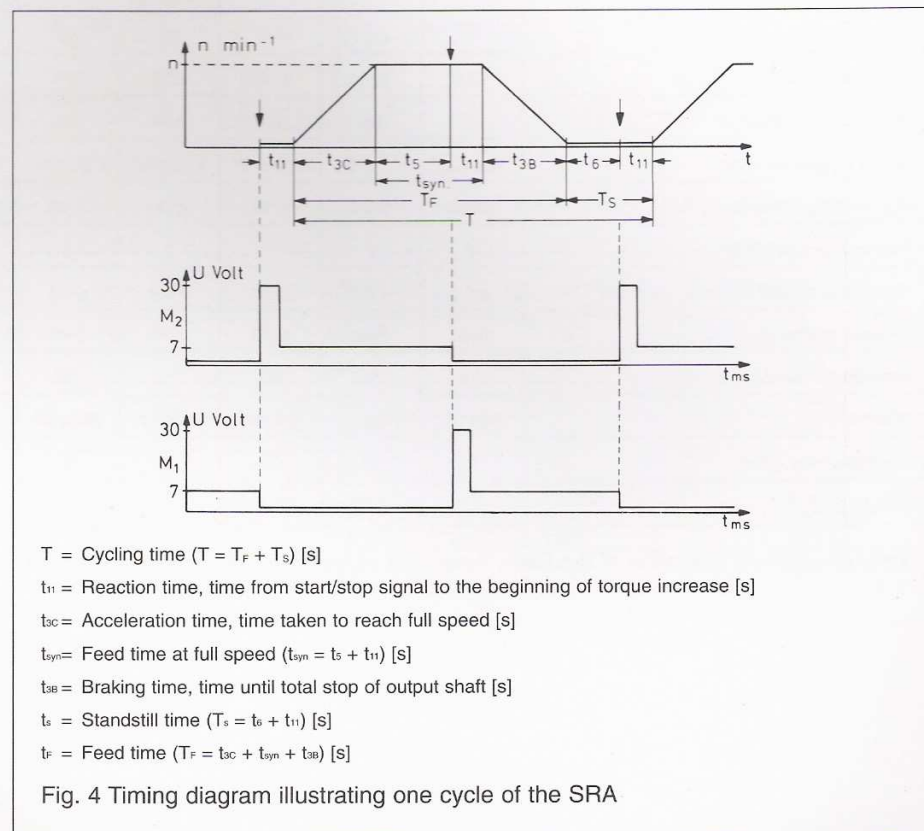

The SRA design permits a response time of 6 to 15 ms (depending on the size of the SRA unit).

Response time: the time it takes from signal input to full rotational torque is built up, see fig. 4.

Data sheet

SRA

Ordering

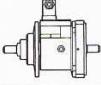
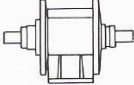
Type		Code no. plain shaft	Code no. with keyway	Symbol
SRA 10	flange mounting	080B0022	080B3022	
SRA 15	foot mounting	080B0001	080B3001	
SRA 18		080B0002	080B3002	
SRA 20		080B0003	080B3003	
SRA 23		080B0004	080B3004	
SRA 25		080B0011	080B3011	
SRA 30		080B0012	080B3012	
SRA 36		080B0013	080B3013	

Technical data

Type	SRA 10	SRA 15	SRA 18	SRA 20	SRA 23	SRA 25	SRA 30	SRA 36
Static torque, [Nm] ≥ Dyn. Torque.								
Dynamic torque, [Nm]	5	11	21	33	44	57	102	167
Max. revolution [min <sup>-1</sup> ] <sup>n</sup> max	1700	1200	1040	920	800	760	600	500
Mx. heat load, [W] P max	70	90	113	135	158	180	271	450
Inertia torque, I <sub>SRA</sub> [kgm <sup>2</sup> ]	12.1x10 <sup>-5</sup>	7.7x10 <sup>-4</sup>	1.08x10 <sup>-3</sup>	1.85x10 <sup>-3</sup>	2.96x10 <sup>-3</sup>	7.27x10 <sup>-3</sup>	14.8x10 <sup>-3</sup>	31.1x10 <sup>-3</sup>
Max. cycling frequency [min <sup>-1</sup> ]	3600	3000	2700	2500	2100	1875	1700	1600
Reaction time t <sub>1</sub> /t <sub>2</sub> [ms]	6	7	7	8	9	10	11	15
Obtainable repeat accuracy, Δt, [ms.]	± 0.1	± 0.1	± 0.1	± 0.1	± 0.1	± 0.1	± 0.1	± 0.1
Ambient temperature* °C	0-40	0-40	0-40	0-40	0-40	0-40	0-40	0-40
Internal volume V <sub>SRA</sub> [10 <sup>-6</sup> m <sup>3</sup> ]	25	50	80	105	115	125	165	230
Nominal work, [J]	80x10 <sup>6</sup>	116x10 <sup>6</sup>	188x10 <sup>6</sup>	232x10 <sup>6</sup>	240x10 <sup>6</sup>	364x10 <sup>6</sup>	544x10 <sup>6</sup>	740x10 <sup>6</sup>
Shaft diameter, [mm]	15	25	25	25	25	40	40	40
Weight, [kg]	2.7	7.65	8.4	9.35	10.2	20.0	22.6	27.0

\*Only at optimum utilisation of the SRA. When not utilised fully, the ambient temperature might be higher.

Technical data  
Permissible shaft loads

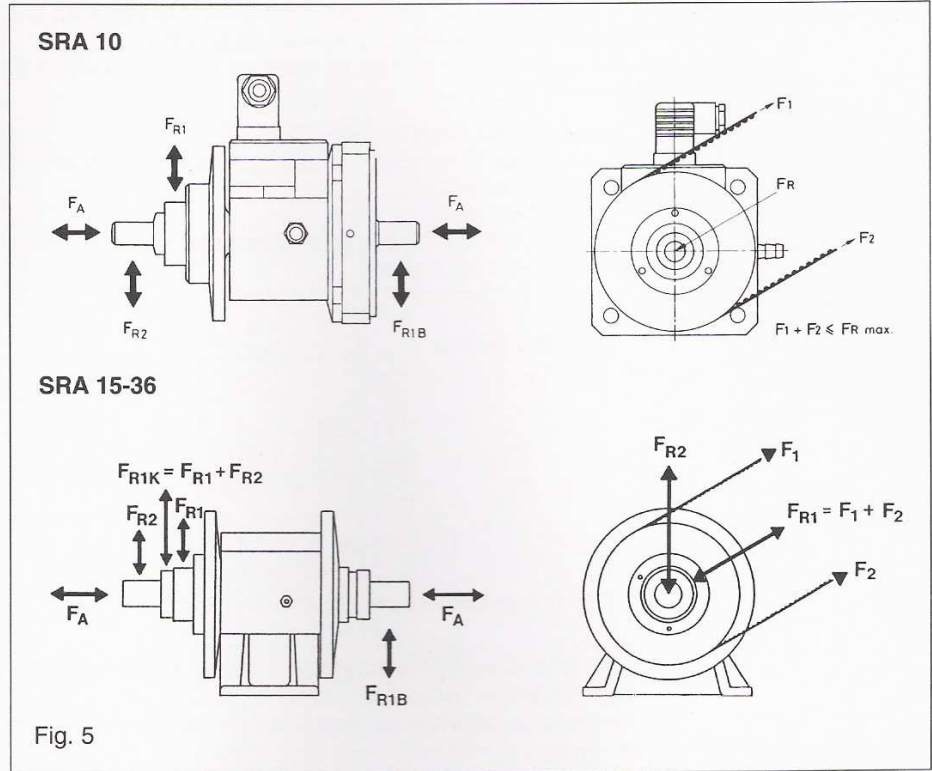

SRA	$F_A$ [N.]	$F_{R1K} \text{max[N.]}$	$F_{R1B} \text{ max[N.]}$
10	250	200	400
15	680	450	900
18	680	450	900
20	680	900	900
23	680	900	900
25	3,630	1,800	1,800
30	3,630	1,800	1,800
36	3,630	1,800	1,800

**Calculation and sizing**

To obtain optimum utilization of the SRA specifications, it is necessary to specify the operation parameters as precisely as possible. The selected SRA unit for an application is based on calculating the necessary dynamic torque.

The calculation must include:

- the masses to be accelerated and decelerated (inertia torque I)
- revolutions/minute
- cycling frequency
- acceleration and deceleration time required
- service interval required

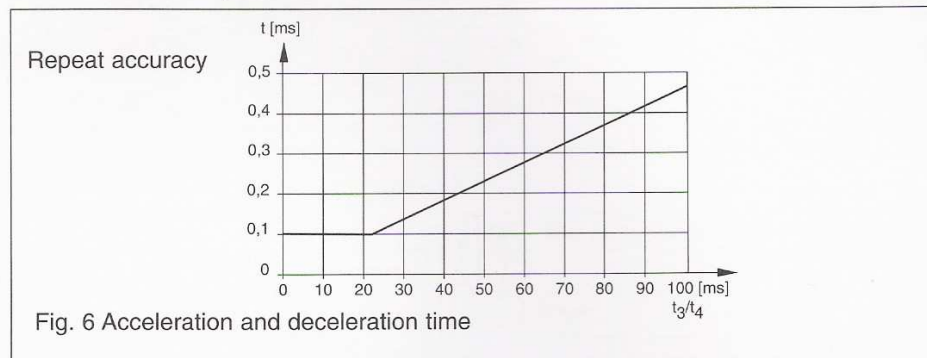

Fig. 6 Acceleration and deceleration time

The obtainable repeat accuracy of the SRA step unit depends on the actual acceleration or deceleration time.

The relation between acceleration or deceleration time and repeat accuracy is shown in fig. 6.

**Sizing of SRA unit**

To select the correct SRA size the following must be known:

- $n$  = revolutions/minute [ $\text{min}^{-1}$ ]
- $I$  = inertia load, [ $\text{kgm}^2$ ]
- $t$  = acceleration or deceleration time [s] (max. 0.025 s when high repeat accuracy is required)
- $F$  = frictional force [N]
- $r$  = radius of feeding roller [m]

Calculation of these data is made on the basis of plant specifications such as measurements of feed rollers, chains etc, cycling frequency, max. feeding length or turning angle and time available per cycle.

The sizing is made according to the torque formula:

$$M = \frac{\sum I \times 2 \times \pi \times n}{60 \times t} + (F \times r) \text{ [Nm]}$$

Repeat accuracy of the SRA is expressed in ms. The tolerance of the required feeding length is the length to be reached in  $\pm 0.1$  ms e.g.: Ex.

$$\begin{aligned} \Delta s &= v \times \Delta t \\ v &= 1 \text{ m/sec} \\ \Delta t &= \pm 0.001 \text{ sec} \\ \Delta s &= (1 \times 0.0001) \text{ m} \\ &= 0.1 \text{ mm} \end{aligned}$$

Hidden tolerance factors that might appear cannot be accumulated in the repeat accuracy calculation.

Sizing examples are available from Laurence Scott & Electromotors Ltd and their engineers are at your service with any required calculation as well as their application experience.

Dimensions SRA 10

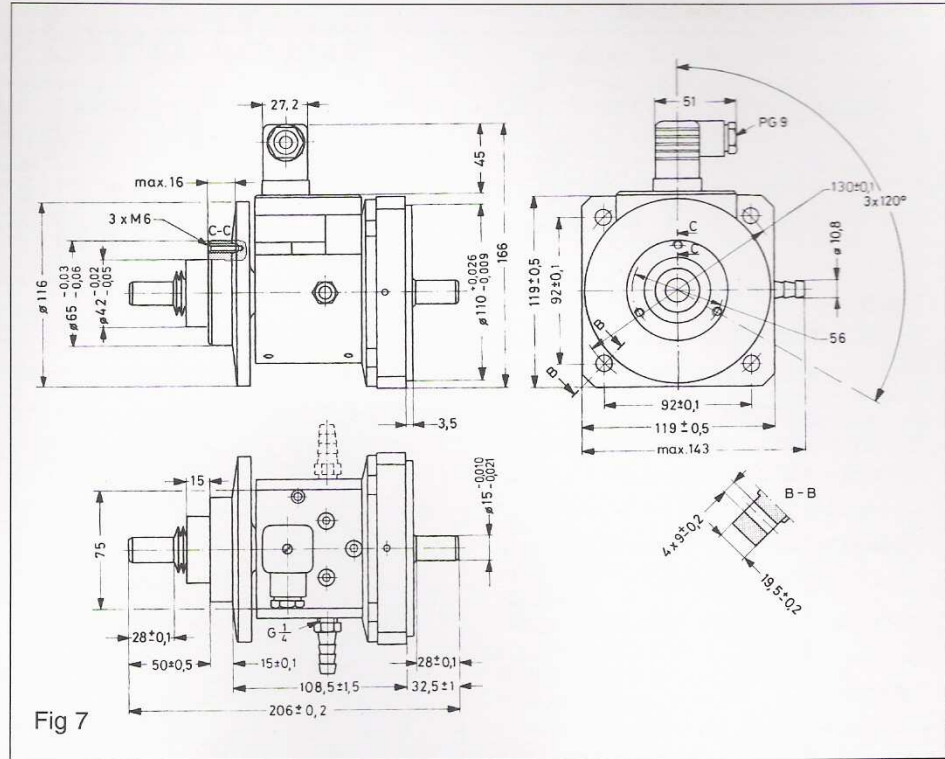

Dimensions SRA 15-36

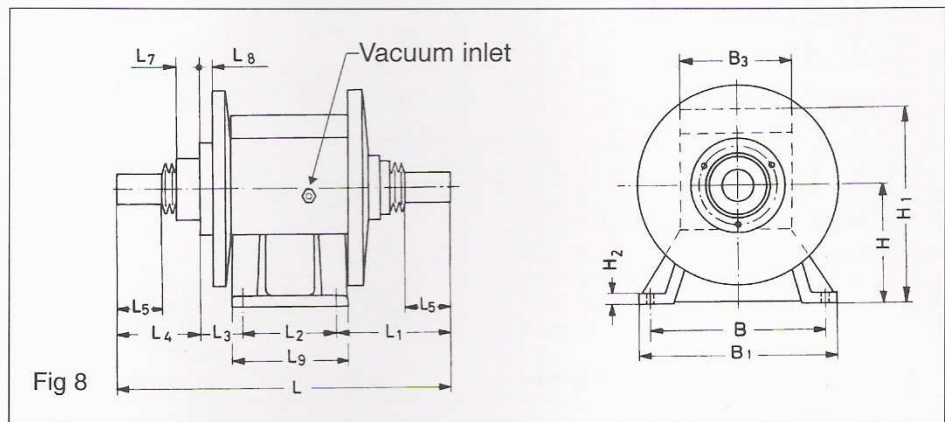

Type	mm												
	H	H1	H <sub>2</sub>	B	B <sub>1</sub>	L	L <sub>1</sub>	L <sub>2</sub>	L <sub>3</sub>	L <sub>4</sub>	L <sub>5</sub>	L <sub>7</sub>	L <sub>8</sub>
SRA 15	100	195	6.5	140	162	326	112	90	50	74	44	19	14.0
SRA 18	100	195	6.5	140	162	326	112	90	50	74	44	19	14.0
SRA 20	125	220	9.0	140	162	326	112	90	50	74	44	19	14.0
SRA 23	125	220	9.0	140	162	326	112	90	50	74	44	19	14.0
SRA 25	160	270	12.5	230	261	437	149	125	58	105	62	27	16.8
SRA 30	160	270	12.5	230	261	437	149	125	58	105	62	27	16.5
SRA 36	200	310	12.5	230	261	437	149	125	58	105	62	27	16.5

Data sheet

SRA

Shaft dimensions SRA 15-36

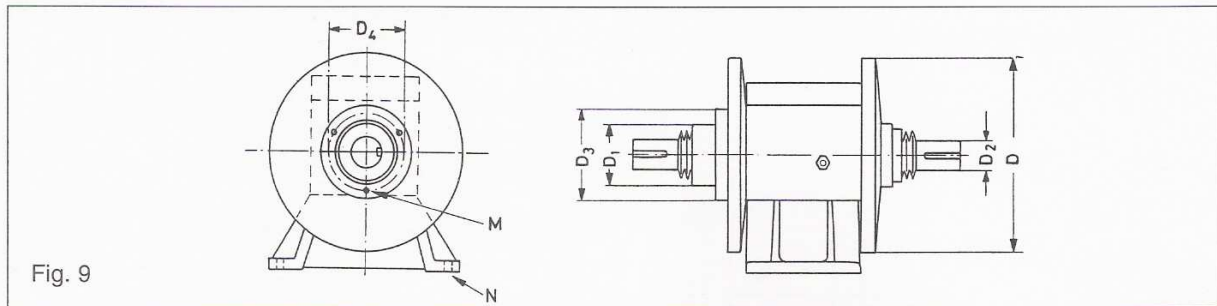

Type	mm								M	N
	ø D	ø D <sub>1</sub>	ø D <sub>2</sub>	ø D <sub>3</sub>	ø D <sub>4</sub>	ø D <sub>5</sub>				
SRA 15	160	70 -0.02 -0.05	25 -0.012 -0.023	100	85	54	3 x M 8 x 20 120° ⊕ ø 0.3	4 x ø 10.5		
SRA 18	186	70 -0.02 -0.05	25 -0.012 -0.023	100	85	54	3 x M 8 x 20 120° ⊕ ø 0.3	4 x ø 10.5		
SRA 20	211	70 -0.02 -0.05	25 -0.012 -0.023	100	85	54	3 x M 8 x 20 120° ⊕ ø 0.3	4 x ø 10.5		
SRA 23	237	70 -0.02 -0.05	25 -0.012 -0.023	100	85	54	3 x M 8 x 20 120° ⊕ ø 0.3	4 x ø 10.5		
SRA 25	263	80 -0.02 -0.05	40 -0.014 -0.025	118	100	89	3 x M10 x 25 120° ⊕ ø 0.3	4 x ø 12.5		
SRA 30	315	80 -0.02 -0.05	40 -0.014 -0.025	118	100	89	3 x M10 x 25 120° ⊕ ø 0.3	4 x ø 12.5		
SRA 36	386	80 -0.02 -0.05	40 -0.014 -0.025	118	100	89	3 x M10 x 25 120° ⊕ ø 0.3	4 x ø 12.5		

Electrical connections  
SRA 10 and SRA 15-36

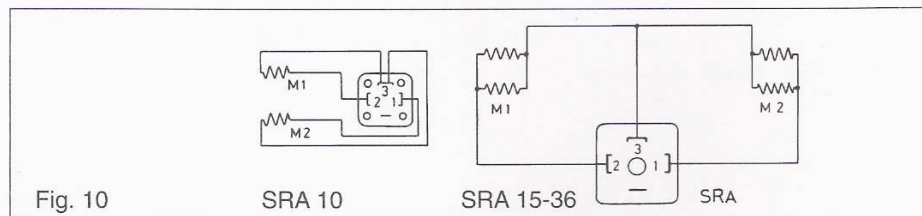

- 1: Solenoid valve, clutch side
- 2: Solenoid valve, brake side
- 3: Junction