

## ERSATZTEILE

## SPARE PARTS

## PIECES DE RECHANGE



## Condaïr CP2

Änderungen vorbehalten!

Subject to change!

Modifications réservées!

Pos.	Artikel Article Article	Typ Type Type	H2-H4 (R1)	N2-N4 (R2)	H5-H8 (S2)	G5-G8 (S3)	F5-F8 (S3)	F9-F15 (S4)	G9-G15 (S5)	F16-F25 (T5)	G16-G21 (T7)	G22-G30 (T7)	F26-F45 (T7)	Art.-/SAP-Nr. Art.-/SAP-No. Art.-/SAP-No.
100	Steuerelektronik ohne Modul Electronics without module Electronique sans module		1	1										1115801
101	Steuerelektronik mit Modul M Electronics with module M Electronique avec module M		1	1										1115802
110	Steuerelektronik ohne Modul Electronics without module Electronique sans module				1	1	1	1	1	1	1	1	1	1115803
111	Modul M3 (kleines Display) Module M3 (small display) Module M3 (display petit)				1	1	1	1	1	1	1	1	1	1115600
112	Modul M4 (grosses Display) Module M4 (large display) Module M4 (display grand)				1	1	1	1	1	1	1	1	1	1115602
113	Relaisprint Relay print Platine à relais	REL			1	1	1	1	1	1	1	1	1	1115604
150	Steuersicherung, Set à 10 Stk. Control fuse, set with 10 pcs. Fusible de commande, set à 10 pcs.	250mAT (5x20mm)	1	1	1	1	1	1	1	1	1	1	1	1115804
200	Anschlussklemmen mit Kabel kpl. Terminal socket with cable cpl. Bloc de bornes avec câble cpl.	KLS KLT			1	1	1	1	1	1	1	1	1	1115606 1115608
201	Erdungsklemme Earth terminal Bloc de terre	16 mm <sup>2</sup> 4 mm <sup>2</sup>	1	1	1	1	1	1	1	1	1	1	1	1115805 1115806
202	Kabeldurchführung Cable glands Passage de câble	PG40 PG60 PG80	1	1	1	1	1	1	1	1	1	1	1	1115609 1101952 1101774
210	Schütz 230V, 50/60Hz Contactor 230V, 50/60Hz Contacteur 230V, 50/60Hz	22 A 35 A 65 A			1	1	1	1	1	1	1	1	1	1115507 1115511 1115809
221	Gummi-Tülle, Set à 2 Stk. Rubber spout, set with 2 pcs. Douille a caoutchouc, set à 2 pcs.		1	1	1	1	1	1	1	1	1	1	1	1102662
230	Erdelektrode Earth electrode Electrode de terre		1	1	1	1	1	1	1	1	1	1	1	1115817 1115818
240	Ventilator Fan Ventilateur	230V, 50/60Hz 24V mit/with/avec Trafo		1										1115819 1119265
—	Transformator für 24V Ventilator Transformer for fan 24V Transformateur pour ventilateur 24V			1										1119266
241	FAN-Gehäuse kpl. FAN case cpl. Boîtier du FAN cpl.			1										1115820
250	Dampfzylinderstecker, 3 Stk. Cylinder plug, 3 pcs. Fiche de connexion du cylindre, 3 pcs.	ø 5mm ø 6mm	1	1	1	1	1	1	1	2	2	2	2	1102495 1101868
	Inbusschlüssel für Dampfzylinderstecker Allan-key for cylinder plug Clé pour pour fiche de connexion du cylindre	ø 5mm ø 6mm	1	1	1	1	1	1	1	1	1	1	1	1115821 1102444



Pos.	Artikel Article Article	Type Type Type	H2-H4	N2-N4	H5-H8	G5-G8	F5-F8	F9-F15	G9-G15	F16-F25	G16-G21	G22-G30	F26-F45	Art.-/SAP-Nr. Art.-/SAP-No. Art.-/SAP-No.
			(R1)	(R2)	(S2)	(S3)	(S3)	(S4)	(S5)	(T5)	(T7)	(T7)	(T7)	
404	Schnapping kompl. Snap-on ring compl. Accouplement à dé clic compl.		1	1	1	1	1	1	1	1	1	1	1	1116602
405	Ventilspule Field coil Bobine de vanne	220-240V, 50Hz 240V, 60Hz	1	1	1	1	1	1	1	1	1	1	1	1106165
406	Hutmutter + Federscheibe (Packung à 10 Stk.) Headscrew + washer (pocket with 10 pcs) Ecrou chapeau + rondelle (paquet à 10 pcs)		1	1	1	1	1	1	1	1	1	1	1	1102383
410	Ablasskanal rund kpl. Drain channel round cpl. Canal d'écoulement rond cpl.		1	1										1115823
411	O-Ring-Set zu Ablasskanal (2 x 1 Stk.) Set o-ring seal for drain channel (2 x 1 pcs.) Set joint o-ring pour canal d'écoulement (2 x 1 pcs.)		1	1										1115824
420	Verschlussplatte Ablasskanal kpl. Trap-cover cpl. Fermeture du canal d'écoulement cpl.				1	1	1	1	1	1	1	1	1	1115825
421	Kerbschraube (Packung à 10 Stk.) Grooved screw (pocket with 10 pcs) Vis à fente (paquet à 10 pcs)	4 x 32mm 4 x 40mm	2	2	2	2	2	2	2	2	2	2	2	1102551 1115826
500	Einlassbecher kpl. Filling cup cpl. Godet de remplissage cpl.		1	1	1	1	1	1	1	1	1	1	1	1115827 1115828
501	Einlassventil Inlet valve Vanne de remplissage	0.45 l/min. 0.45 l/min. 1.2 l/min. 2.5 l/min.	1	1	1	1	1	1	1	1	1	1	1	1115829 1115830 1115831 1115832
510	Gummischlauch-Set kpl. Set rubber hose cpl. Set de tuyau en caoutchouc cpl.		1	1	1	1	1	1	1	1	1	1	1	1115833 1115834 1115835
520	Schlauchklemmen-Set (2xø21mm/2xø16mm) Set hose clip Set serre-joint de tuyau		1	1	1	1	1	1	1	1	1	1	1	1115836
530	Dampfschlauch (per m) Steam hose (per m) Tuyau de vapeur (par m)	DS22 (ø 29/22mm) DS60 (ø 38/30mm) DS80 (ø 54/45mm)	x	x	x	x	x	x	x	x	x	x	x	1105176 1103922 1102878
531	Dampfschlauchbogen kpl. Steam hose bend cpl. Tuyau de vapeur, coudé cpl.			1										1115837
532	Kondensatschlauch (per m) Condensate hose (per m) Tuyau de condensat (par m)	ø 9.5/5mm ø 12/8mm	x	x	x	x	x	x	x	x	x	x	x	1103375 1103350
540	Wasseranschluss kpl. Water supply cpl. Alimentation d'eau cpl.		1	1	1	1	1	1	1	1	1	1	1	1101621
550	Dampfdüse kpl. Steam nozzle cpl. Gicleur de vapeur cpl.	W21	1											1115610
560	Drehverschluss kpl. Catch lock cpl. Fermeture à tournique cpl.		1	1	1	1	1	1	1	1	1	1	1	1102353
600*	Bodenschale Bottom plate Couvercle inférieur		1	1	1	1	1	1	1	1	1	1	1	1114732 1114723 1114724
610*	Gehäusetüre Housing door Porte du boîtier	Standard INOX Standard INOX Standard INOX Standard INOX	1 1 1 1 1 1											1114728 1115848 1114729 1115847 1114718 1115846 1114722 1115845
620	Schlauchplatte Cover plate Plaque de couverture	ø30 mm ø39 mm ø55 mm			1	1	1	1	1	1	1	1	1	1117592 1117593 1117594

\* **Lieferfrist ca. 6 Wochen / delivery time approx. 6 weeks / délai de livraison approx. 6 semaines**

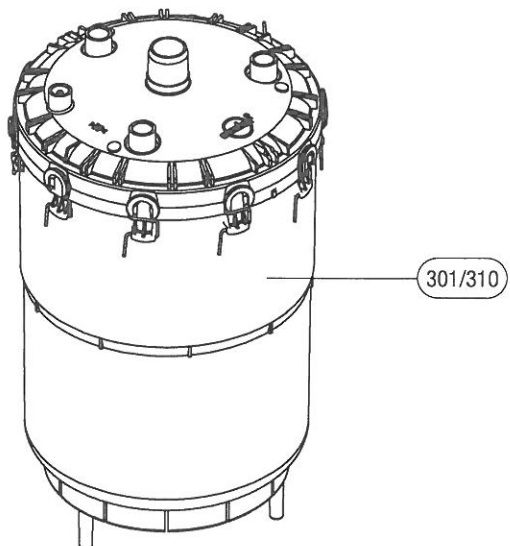
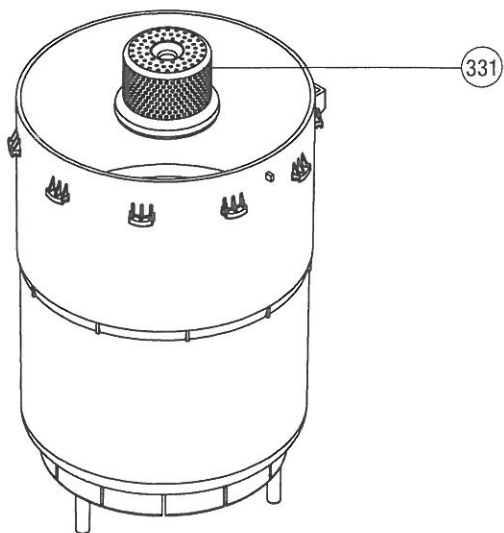
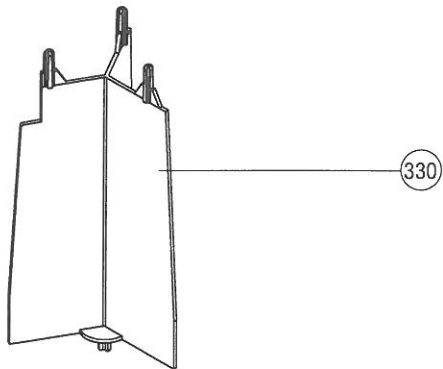
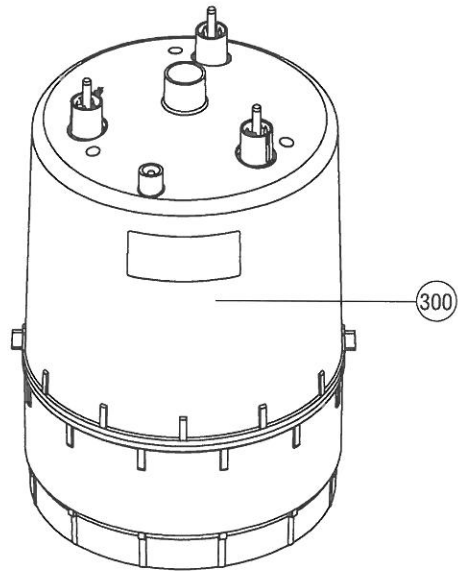
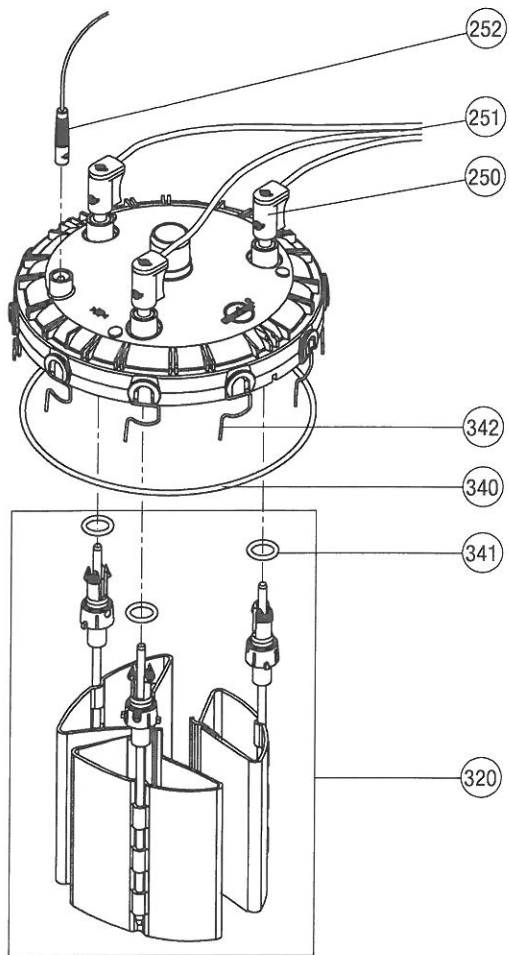

CP2 Typ R mit/ohne FAN  
CP2 Type R with/without FAN  
CP2 Type R avec/sans FAN

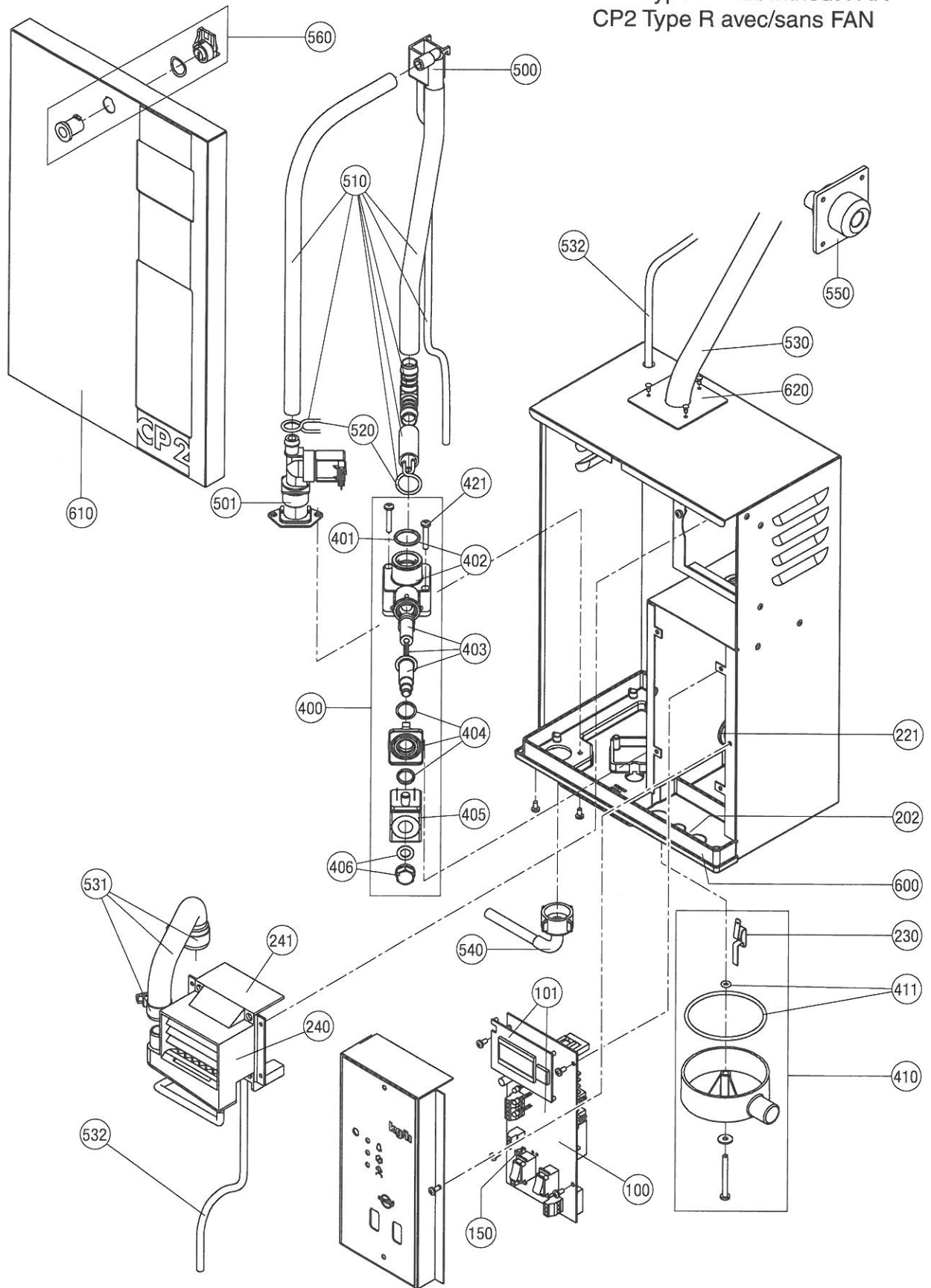

CP2 Typ S und T  
 CP2 Type S and T  
 CP2 Type S et T

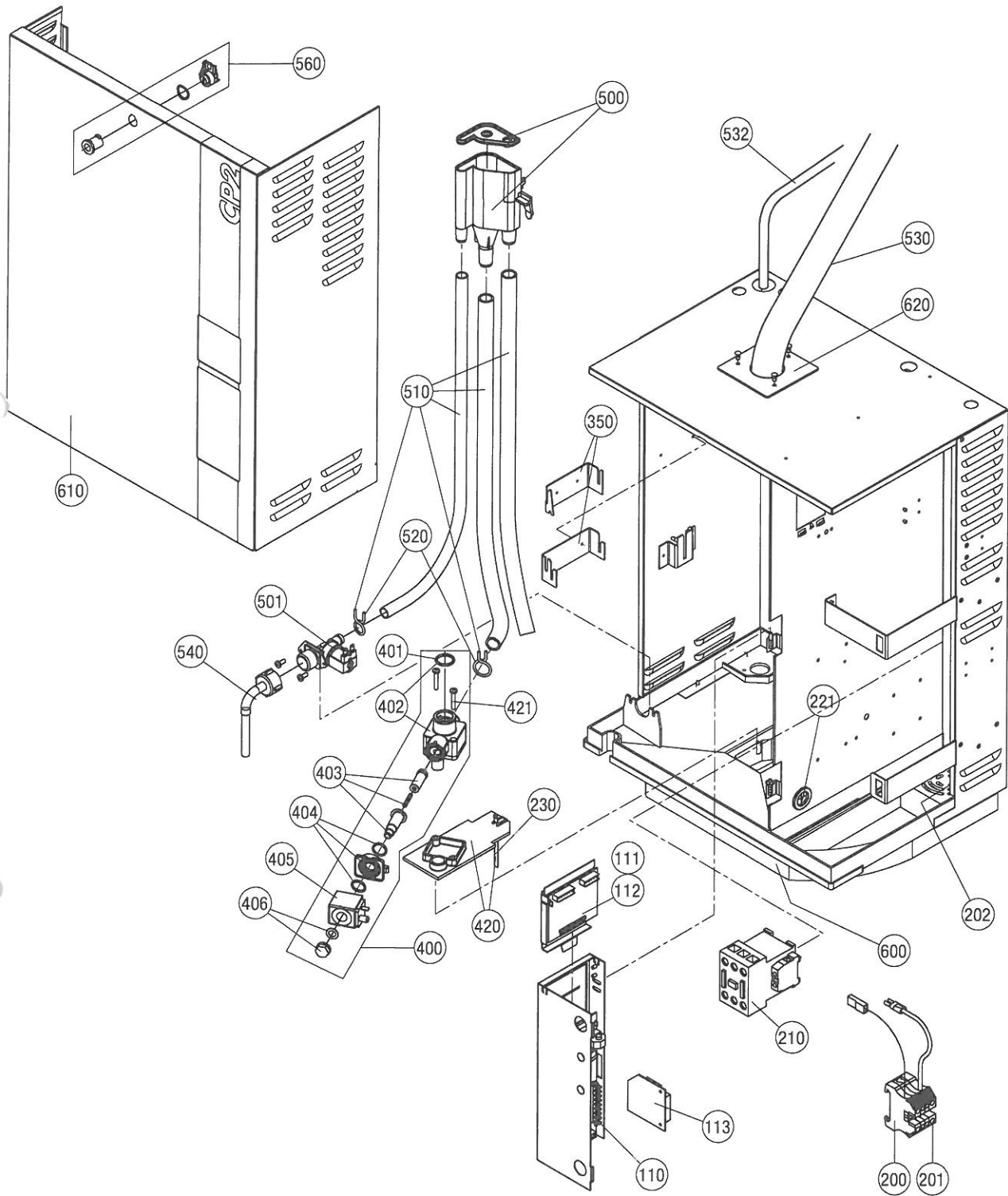

Manufacturer:  
**Axair Ltd.** Systems for Air Treatment  
 A WMH Company  
 CH-8808 Pfäffikon (Switzerland), Talstr. 35-37, P.O. Box  
 Telephone +41 55 416 61 11, Fax +41 55 416 62 62  
 Internet <http://www.axair.ch>, E-Mail [info@axair.ch](mailto:info@axair.ch)

