



Änderungen vorbehalten!

Subject to change!

Modifications réservées!

Pos	Artikel/Article/Article	Pro					Art.-/SAP-No.	
		Heizspannung Heating voltage Tension de chauffage	230V/1	400V/3	400V/3	400V/3		
		Dampfleistung [kg/h] Steam capacity [kg/h] Capacité de vapeur [kg/h]	5-8	5-8	9-15	16-25	26-45	
100	Steuerelektronik Control PCB Unité de commande		1	1	1	1	1	2530130
101	Leistungssprint Power board Platine de puissance		1	1	1	1	1	2530144
102	Bedienpanel kpl. Control panel cpl. Panneau de commande cpl.		1	1	1	1	1	2530143
103	Folientastatur Keypad Clavier		1	1	1	1	1	2530135
104	Netzschalter Power switch Interrupteur du réseau		1	1	1	1	1	2530137
105	Betriebs- und Störungsferrmeldung Remote operation and fault indication Télésignalisation de travail et de dérangement		1	1	1	1	1	2529378
106	Schütz 230V, 50/60Hz Contactor 230V, 50/60Hz Contacteur 230V, 50/60Hz	25 A 50 A 65 A	1	1	1	1	1	1115507 1115511 1115809
107	Erdungsklemme Earth terminal Bloc de terre	10mm ² 16mm ²	1	1	1	1	1	2530794 2530795
108	Schlauchklemme ø21.0-22.0, 5 Stk. Hose clamp ø21.0-22.0, 5 pcs Pince à tuyau ø21.0-22.0, 5 pcs		x	x	x	x	x	2553596
110	Erdelektrode Earth electrode Electrode de terre		1	1	1	1	1	2530139
111	Schlauchset Einlass Hose set inlet Set de tuyau d'alimentation		1	1	1	1	1	2530186 2530187
112	Schlauchset Pumpe Hose set pump Set de tuyau pompe		1	1	1	1	1	2530188 2530189
113	Entleerungsschlauch Draining hose Tuyau de vidange		1	1	1	1	1	2530190 2530191
114	Schlauchklemme ø30.7-31.7, 5 Stk. Hose clamp ø30.7-31.7, 5 pcs Serre-joint pour tuyau ø30.7-31.7, 5 pcs		x	x	x	x	x	2519405
115	Schlauchklemme ø19.0-19.5, 5 Stk. Hose clamp ø19.0-19.5, 5 pcs Serre-joint pour tuyau ø19.0-19.5, 5 pcs		x	x	x	x	x	2519409
116	Schlauchklemme 30/9, 5 Stk. Hose clamp 30/9, 5 pcs Collier de serrage 30/9, 5 pcs		x	x	x	x	x	2522886
117	Einlassventil Inlet valve Vanne de remplissage	0.5 l/min. 1.2 l/min. 2.5 l/min.	1	1	1	1	1	2537275 2537276 2537277
118	Synchronpumpe kpl. Synchronous pump cpl. Pompe synchrone cpl.		1	1	1	1	1	1115532
119	Dichtring Pumpengehäuse Gasket for pump housing Joint pour boîtier de pompe		1	1	1	1	1	2550469

Pos	Artikel/Article/Article	Pro					Art.-/SAP-No.			
		Heizspannung Heating voltage Tension de chauffage			Dampfleistung [kg/h] Steam capacity [kg/h] Capacité de vapeur [kg/h]					
		230V/1~	400V/3~	400V/3~	400V/3~	400V/3~				
			5-8	5-8	9-15	16-25	26-45			
120	Kupplungsmuffe kpl. Coupling sleeve cpl. Manchon d'accouplement cpl.				1	1	1	1	1	2530176
121	O-Ring, 10 Stk. O-ring seal, 10 pcs Joint O-ring, 10 pcs				x	x	x	x	x	1102867
122	Wasserbecher kpl. Water cup cpl. Godet d'eau cpl.				1	1	1	1	1	1115542
123	Ablaufbecher kpl. Drain cup cpl. Godet d'écoulement cpl.				1	1	1	1	1	1115534
124	Dichtung Ablaufbecher Gasket drain cup Joint godet d'écoulement				1	1	1	1	1	2530424
125	Ablaufstutzen kpl. Drain connection cpl. Manchon d'écoulement cpl.				1	1	1	1	1	1103890
126	Schlauchklemmsset Hose clip set Set serre-joint de tuyau				1	1	1	1	1	1115548
127	PEX-Schlauchgarnitur PEX hose Tuyau PEX				1	1	1	1	1	1103857
128	Dampfzylinderhalterung Cylinder fixing Fixation du cylindre		ø 22 mm ø 30 mm ø 45 mm		1	1				2530331 2530332 2530333
130	Ausblasstutzen kpl. Steam outlet hose cpl. Manchon de vaporisation cpl.		ø22/ø33 ø30/ø30 ø42/ø45		1	1				2530206 2530207 2530208
131	Dampfschlauchanschluss kpl. Steam hose connection cpl. Raccord tuyau de vapeur cpl.		SC22 SC60 SC80		1	1				2529363 2529364 2529365
132	Dampfschlauchanschluss Steam hose connection Raccord tuyau de vapeur		ø 22 mm ø 30 mm ø 45 mm		x	1				2530448 2530449 2530450
133	Dampfschlauch Steam hose Tuyau de vapeur		DS22 (ø22/31mm) DS60 (ø30/40mm) DS80 (ø45/57mm)		x	x				1105176 1103922 1102878
134	Schlauchbride, 2 Stk. Screw hose clamp, 2 pcs Collier de serrage, 2 pcs		für / for / pour DS22 für / for / pour DS60 für / for / pour DS80		x	x				1100432 2538894 2538898
---	Kondensatschlauch Condensate hose Tuyau de condensat		KS10 (ø8/12mm)		x	x	x	x	x	1103350
140	Verschluss kpl., 2 Stk. Door lock cpl., 2 pcs Fermeture cpl., 2 pcs				1	1	1	1	1	2530425
141*	Gehäusetüre Housing door Porte du boîtier		Standard Standard INOX INOX		1	1				2552898 2552900 2552903 2552904
---*	Gehäusetüre ohne Displayausschnitt (B-Gerät) Housing door without display cutout (Unit B) Porte du boîtier sans découpe affichage (Appareil B)		Standard INOX							2552901 2552907
142	Montage-Profil Mounting profile Support mural				x	x	x	x	x	2529544
---	Kabel Steuerelektronik -> Leistungsprint Cable control PCB -> power board Câble unité de commande -> platine de puissance				1	1	1	1	1	2530238
---	Kabel Ventil + Pumpe Cable valve + pump Câble vanne + pompe				1	1				2530239 2530240
---	Kabel RFI -> Steuerelektronik Cable RFI -> control PCB Câble RFI -> unité de commande				x	x	x	x	x	2568207

Pos	Artikel/Article/Article	Heizspannung Heating voltage Tension de chauffage	Pro					Art.-/SAP-No.
			230V/1~	400V/3~	400V/3~	400V/3~	400V/3~	
			Dampfleistung [kg/h] Steam capacity [kg/h] Capacité de vapeur [kg/h]	5-8	5-8	9-15	16-25	
--	Sicherung, 3 Stk. Fuse, 3 pcs Fusible, 3 pcs Fusible, 3 pcs	200mA F 6.3A T 100mA T 315mA F	x x x x	x x x x	x x x x	x x x x	2536024 2536025 2543802 2577833	
200	Sensorstecker mit Kabel Sensor plug with cable Fiche de connexion du senseur avec câble	ø 5mm	1	1	1	1	1	1115822
201	Kabelbaum kpl. Cable tree cpl. Faisceau de câble cpl.		1	1	1	1	1	2530830 2530098 2530099 2530100 2530102
202	Dampfzylinderstecker, 3 Stk. Cylinder plug, 3 pcs Fiche de connexion du cylindre, 3 pcs	ø 5mm ø 6mm	1	1	1	2	2	1102495 1101868
203	Klammern zu reinigbarem Dampfzylinder, 4 Stk. Clip to cleanable steam cylinder, 4 pcs Clip pour cyl. à vapeur nettoyable, 4 pcs		x	x	x	x	x	1115790
204	O-Ring zu reinigbarem Dampfzylinder O-ring seal to cleanable steam cylinder O-ring pour cylindre à vapeur nettoyable	D301 D401 D601	x	x	x	x	x	1115787 1115788 1115789
205	Dichtungsring zu reinigbarem Dampfzylinder, 4 Stk. Seal ring to cleanable steam cylinder, 4 pcs Joint ring pour cylindre à vapeur nettoyable, 4 pcs		x	x	x	x	x	1102225
206	Elektroden-Set (ohne Schikane) Set electrodes (without divider) Set electrodes (sans chicane de separation)	E342 (D342) E343 (D343/363) E444 (D444/464) E644 (D644/664) E654 (D654/674)	1	1	1	1	1	1115779 1115780 1115781 1115782 1115783
207	Schikanen zu reinigbarem Dampfzylinder Divider to cleanable steam cylinder Chicane de séparation pour cylindre à vapeur nettoyable	D363 D464 D664/674	x	x	x	x	x	1115784 1115785 1115786
208	Sieb zu reinigbarem Dampfzylinder Strainer to cleanable steam cylinder Filtre de séparation pour cylindre à vapeur nettoyable	3-600	x	x	x	x	x	1106695
209	Austauschzylinder Exchange cylinder Cylindre à échanger	A342 A363 A464 A664 A674	1	1	1	1	1	5020006 5020010 5020014 5020024 5020025
210	Reinigbare Zylinder mit Elektroden Cleanable steam cylinder with electrodes Cylindre nettoyable avec électrodes	D342 D363 D464 D664 D674	x	x	x	x	x	5020032 5020036 5020038 5020041 5020042
211	Reinigbarer Dampfzylinder (leer) Cleanable steam cylinder (empty) Cylindre à vapeur nettoyable (vide)	D301 D401 D601	x	x	x	x	x	1115776 1115777 1115778

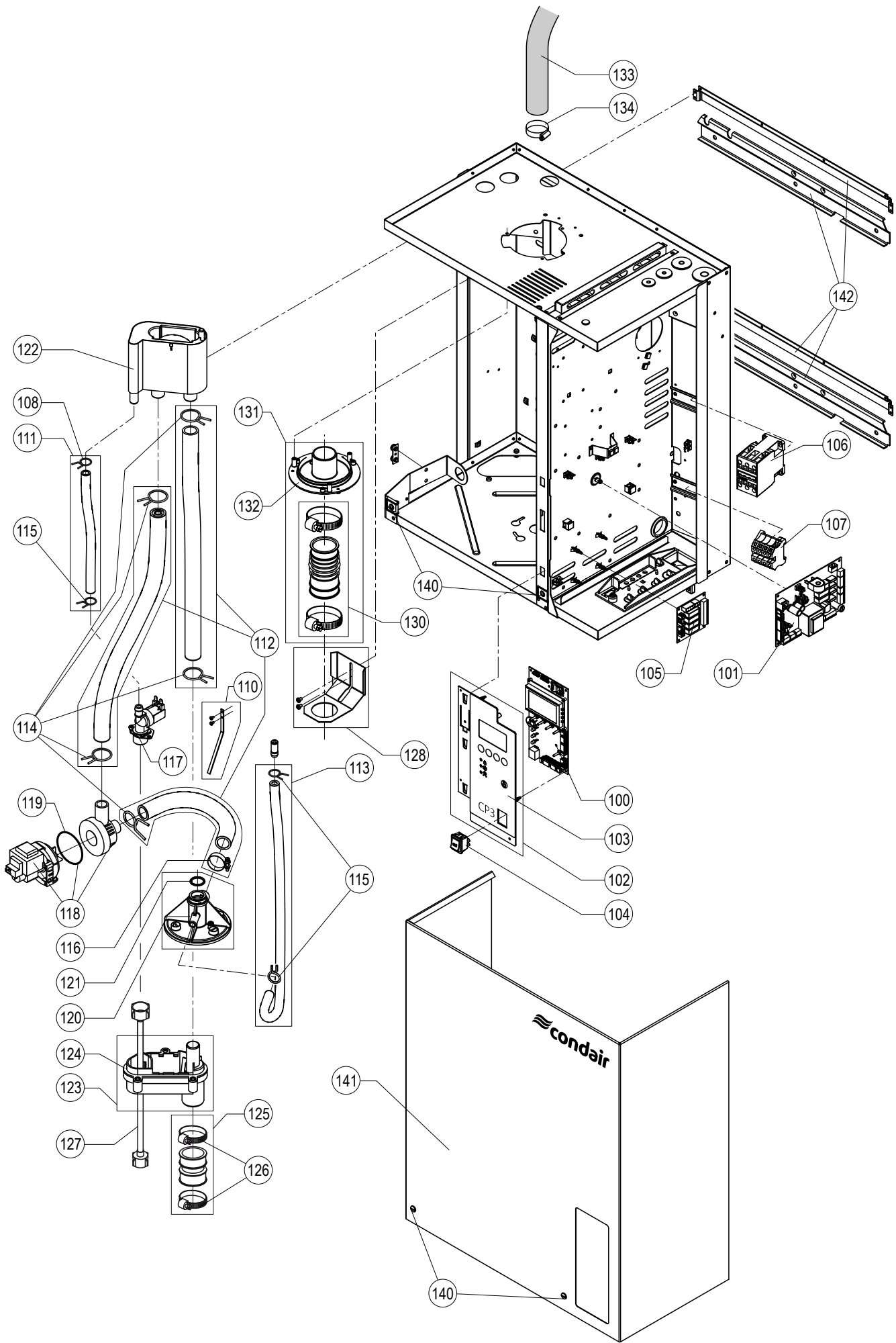

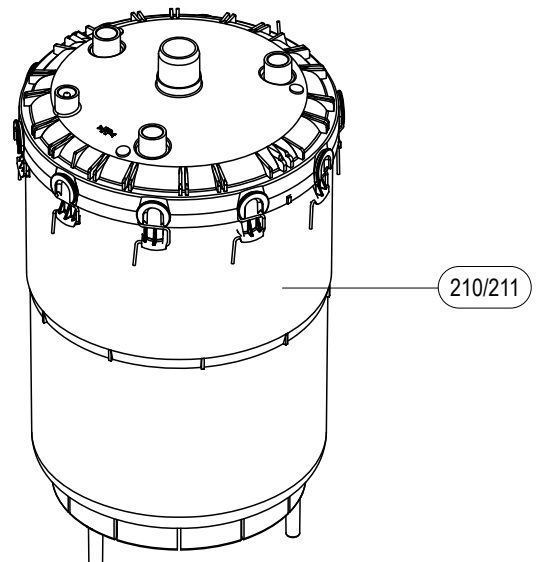
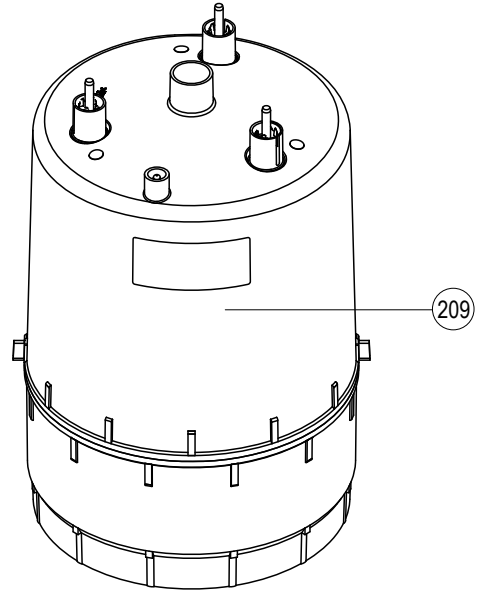
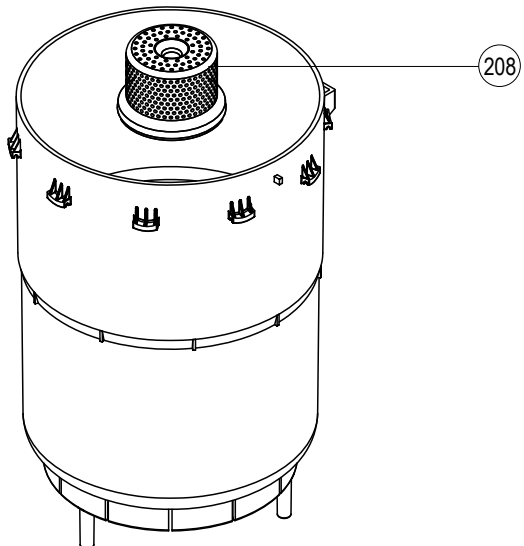
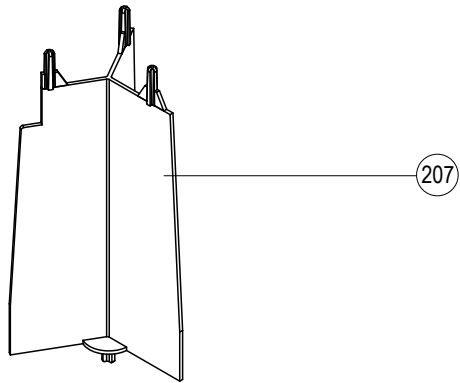
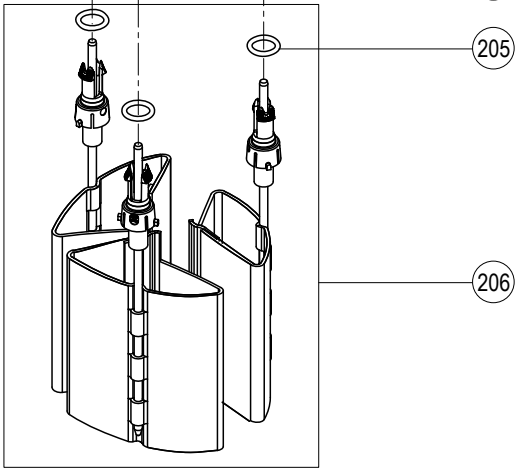
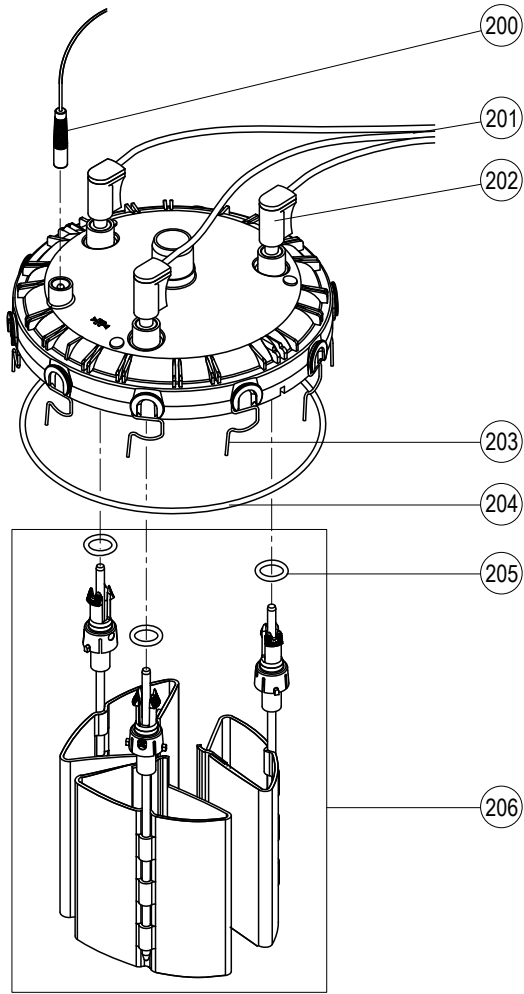

Manufacturer:
Condair Ltd.
Talstrasse 35-37, 8808 Pfäffikon, Switzerland
Ph. +41 55 416 61 11, Fax +41 55 416 62 62
info@condair.com, www.condair.com