

S4560

AUTOMATIC IGNITION CONTROL

INSTRUCTION SHEET

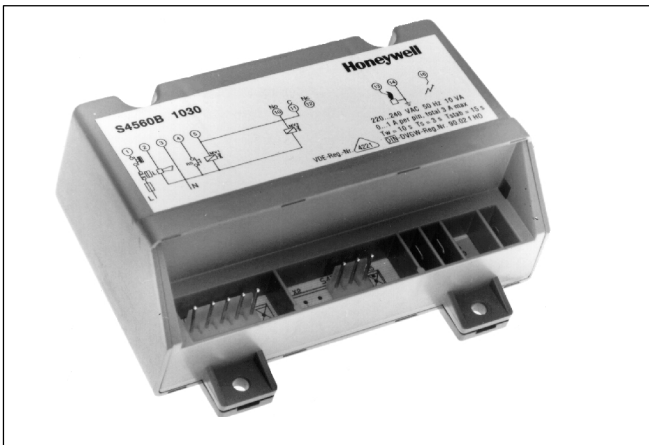

APPLICATION

The S4560 provides automatic ignition and control for burners in accordance with EN 298.

SPECIFICATIONS

Model

S4560: 220 ... 240 V, 50 Hz.

Suffix A: For atmospheric burners. Non volatile lock out in accordance with EN 298.

Suffix B: As suffix A except a built in flame indication relay for modulating applications.

Suffix C: For fan assisted applications. Non volatile lock out in accordance with EN 298.

Suffix D: As suffix C except a built in flame indication relay for modulating applications.

Suffix E: As suffix A except lock-out after flame lost during normal operation.

Suffix P: As suffix A except volatile lock out, reset by interrupting heat demand.

Suffix Q: As suffix B except volatile lock out, reset by interrupting heat demand.

Suffix R: As suffix C except volatile lock out, reset by interrupting heat demand.

Suffix T: As suffix D except volatile lock out, reset by interrupting heat demand.

Dimensions

See fig. 9.

Ambient temperature

0 ... 60 °C

Relative humidity

90% max. at 40 °C (non condensing)

Supply voltage

Line voltage, 220 V (-15%) ... 240 V (+10%), 50 Hz (± 2 Hz)

Power consumption

10 VA max.

Electrical rating

Valve(s) output: 1 A max $\cos \varphi > 0.6$

Fan output (Suffix C, D, R and T): 1 A max $\cos \varphi > 0.6$

Alarm output: 1 A max $\cos \varphi > 0.6$

Flame indication relay: 1 A max $\cos \varphi > 0.6$

External ignition transformer: 1 A max $\cos \varphi > 0.6$

All outputs together: 3 A max.

Electrical connection

High tension spark: 2.8 x 0.5 mm spade terminal.

Flame rod and ground: 6.3 x 0.8 or 4.8 x 0.8 mm spade terminal (depending on O.S. number).

Multiple connector: Molex 3001 series

Timing (depending on O.S. number)

Waiting time (T_w)/Prepurge time (T_p): 0 ... 24 s

Safety time (T_s): 0 ... 250 s

Stabilization time (T_{stab}): 0 ... 15 s

Flame sensing

Flame sensing is based on the rectification principle.

Minimum flame current: 0.7 μ A

Response time "ON": < 200 ms (at 2 μ A flame current)

Response time "OFF": < 1 s

Maximum cable length: 1 m

Not protected against electrical shock.

Ignition

Integral electronic spark generator

Spark voltage: 12 kV at 40 pF load

Repetition rate: 12 Hz

Maximum cable length: 1 m

Not protected against electrical shock.

Contents

English Page 1 ... 10

Deutsch Seite 11 ... 13

Nederlands Bladzijde 14 ... 16

Fusing

Automatic ignition control should be externally fused to prevent damage to automatic ignition control, wiring or peripherals.

External fuse: 16 A slow max.

Enclosure

IP 00

Recommended flame sensor

Q375 Spark igniter or flame sensing electrode

Q354 Flame sensor

Accessories (to be ordered separately)

Multiple connectors including 1 m leads, order number:

3 pole (suffix B, C, Q and R): 45.900.419-002

5 pole(suffix A, B, C, D and E): 45.900.419-003

6 pole (suffix D and T): 45.900.419-004

High voltage cable (500 mm): 45.900.411-001

SYSTEM OPERATION

IMPORTANT

*The automatic ignition controls **S4560P, Q, R, and T** do not have an independant manual reset function. The application of these types is therefore restricted to only those applications where resetting by switching off the heat demand is allowed.*

Automatic ignition control for atmospheric appliances

See fig. 3. and 4. for suffix A, B, P and Q and fig 7. for suffix E

When there is a call for heat, a waiting period (T_w) elapses before built-in or external igniter and gas valve is switched on.

Ignition spark ignites gas and resulting flame is detected by the flame rod.

Internal ignition is switched off immediately after flame is established and -if appropriate- external ignition is switched off after elaps of stabilisation time.

If flame is not established within the safety time (T_s), the automatic ignition control locks-out.

If flame is lost during normal run, the automatic ignition control repeats start sequence (except suffix E).

In case of ignition control with LPG valve connection, gas pressure switch and TTB switch, the ignition control waits for gas pressure before normal sequence is started.

If TTB switch becomes active all valves are de-energized.

The TTB switch has to be reset before sequence will start again.

Automatic ignition control for fan assisted appliances

See fig. 5. and 6. for suffix C, D, R and T

When there is a call for heat, fan is energized if air proven switch is in the "NO AIR" position.

When sufficient air flow is proven by the air proving switch, a prepurge period (T_p) elapses before built-in or external igniter and gas valve is switched on.

Ignition spark ignites gas and resulting flame is detected by the flame rod.

Internal ignition is switched off immediately after flame is established and -if appropriate- external is switched off after elaps of stabilisation time.

If flame is not established within the safety time (T_s), the automatic ignition control locks-out.

If air flow is not proven by air proving switch, automatic ignition control will remain in a waiting mode with fan energized.

If flame is lost during normal run, the automatic ignition control repeats start sequence.



WARNING

If fan/air proving switch response time is ≤ 1 s, an orifice in the air flow switch tube must be mounted in order to avoid cycling.

lock-out reset

The auto ignition control will be reset by either depressing the internal or the external reset button in the external wiring (suffix A, B, C, D and E) or by interrupting the power supply (suffix P, Q, R and T).

If a first reset is not succesful wait at least 15 seconds before making another reset.

INSTALLATION AND CHECKOUT

IMPORTANT

Installer must be a trained experienced service man.

Disconnect power supply to prevent electrical shock and/or equipment damage.

Before installing or replacing any control check that type number is correct for the application. Never use a type with a larger safety time for which the appliance is approved.

The appliance manufacturer's instructions should always be followed when provided. If such instructions are not provided see fig. 11. ... 19. for typical systems.

Ensure combustion chamber is free of gas before start up.

Conduct a thorough check out when installation is completed.

At the first start the automatic ignition control can be in lock-out; reset to free the control.



WARNING

After moving S4560 automatic ignition control from outdoor to indoor conditions, condensation may occur. Do not connect condensated automatic ignition control to mains.

Mounting

The automatic ignition control should be mounted on a flat surface by means of 4 mounting holes (see fig. 9.).

Mounting position

The automatic ignition control functions position independently.

To ensure reliable long term operation mount automatic ignition control at a position in the appliance with a low ambient temperature and low radiation.

Wiring



CAUTION

Wiring must be in accordance with local regulations.
Never combine high tension wiring with other wiring.

- Use untinned receptacles for easier connection.
- Use leadwire which can withstand 105 °C ambient.
- Use leadwire which is proven against moisture.
- Wiring between automatic ignition control and spark sensing electrode should have good quality insulation, suitable for the temperatures encountered.
- Length of wiring for external components: 1 m max.

Wiring to automatic ignition controls (see fig. 1.)

1. Ground wire has large self inductance due to long length.
2. High tension wire has large capacitive coupling to other wire

Results of 1. and 2. :

Sparks and flash over on PCB
Damage of PCB

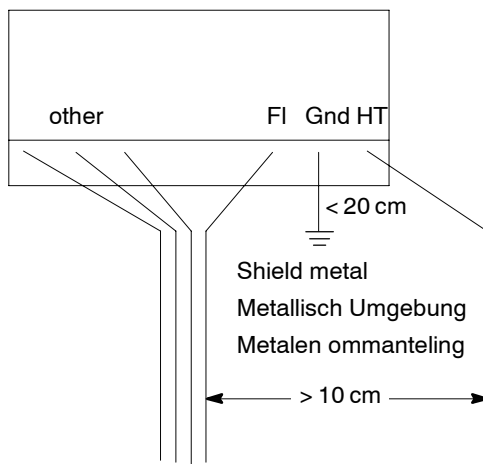
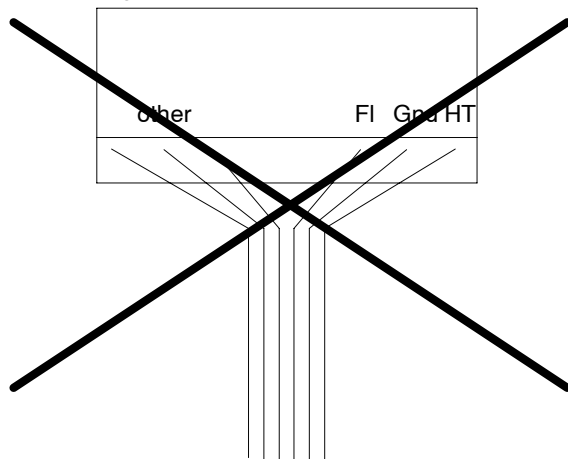

Fig. 1. Wiring to automatic ignition control
Bild 1. Verdrahtung des Gasfeuerungsautomats
Fig. 1. Bedrading van de branderautomaat

Supply voltage polarity



WARNING

If automatic ignition control seems to operate normally but does not detect ignition flame, check for right polarity of power supply (line, neutral).

Spark gap

Refer to the appliance manufacturer's instructions for recommended ignition electrode position.
Maximum allowable spark gap: 3.5 mm.

Checking flame current

- The minimum value should be 0.7 μ A.
- To check flame current connect a DC micro-Ampèremeter between flame sensing wire and flame sensor rod.
- If flame current is insufficient check that flame sensing rod is fully enveloped by the flame and that burner is reliable grounded to automatic ignition control.

Checkout

After installation, set burner system in operation and observe through a complete cycle to ensure that burner system components function correctly.

GENERAL CONSIDERATIONS

The automatic ignition control should be externally fused.

The automatic ignition control contains no serviceable parts. Any attempt of replacement of parts will affect the safety of this device and is therefore not allowed.

High temperatures will affect product life.

When the automatic ignition control is built in an appliance, the total protection must be IP 40 at least.

To ensure reliable long term operation, mount automatic ignition control at a position in the appliance with a low ambient temperature and a low radiation.

For safety a high limit thermostat must be connected in series with the comfort controls to de-energize the automatic ignition control in case of over temperature.

To suppress Radio Frequency Interference (RFI) the spark electrode cabling should be mounted in a sufficient shielded environment.

NOTE: Electrical rating of connected controls and air proving switch should be appropriate for the load that is switched by the automatic ignition control.

NOTE: The emission level in accordance with EN 55014 generated by the electronic ignition is in some applications higher than allowed and need to be checked.
Additional EMC filter may be needed.













	GB	D	NL
	Thermostat	Temperaturregler	Regelthermostaat
	Gas valve	Gasventil	Gasklep
	Ignition	Zündung	Ontsteking
	Flame rod	Ionisationselektrode	Ionisatie-elektrode
	Fan	Gebälse	Ventilator
	Limitier	Begrenzer	Maximaal beveiliging
	Reset switch	Entriegelung	Ontgrendeling
	Flame indication relay	Flammenmelderelais	Vlamindicatierelais
	Alarm	Alarm	Alarm
	Air proving switch	Luftdruckschalter	Luchttransportschakelaar
	External ignition transformer	Externe Zündeinheit	Externe ontstektransformator
	Down draught supervision TTB	Rauchgasüberwachung	Thermische terugslag beveiliging
	Gas pressure switch GPS	Gasdruckwächter	Gasdruckschakelaar

Fig. 2. Legend
Bild 2. Legende
Fig. 2. Legenda

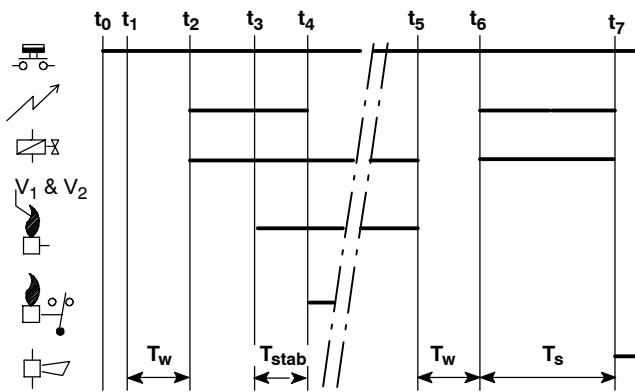

Fig. 3. Functional diagram S4560A, B, P, Q with potential free flame relay connection
Bild 3. Programmablauf S4560A, B, P, Q mit spannungsfreiem Flammenrelais Anschluss
Fig. 3. Functie diagram S4560A, B, P, Q met spanningsvrije vlamrelais aansluiting

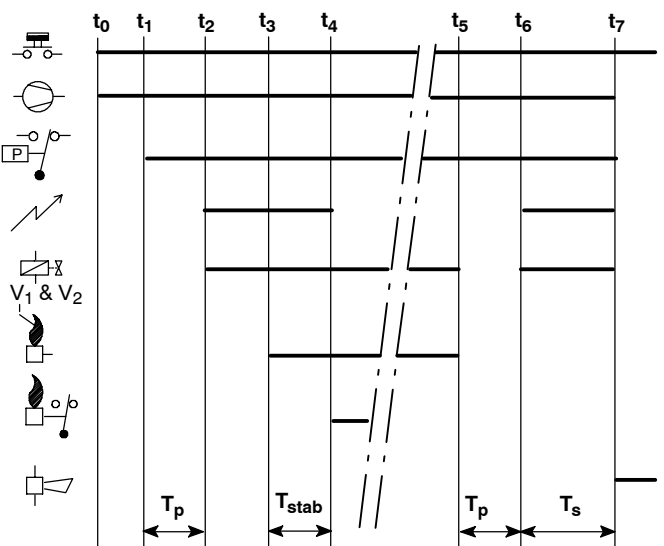

Fig. 5. Functional diagram S4560C, D, R, T with potential free flame relay connection
Bild 5. Programmablauf S4560C, D, R, T mit spannungsfreiem Flammenrelais Anschluss
Fig. 5. Functie diagram S4560C, D, R, T met spanningsvrij vlamrelais aansluiting

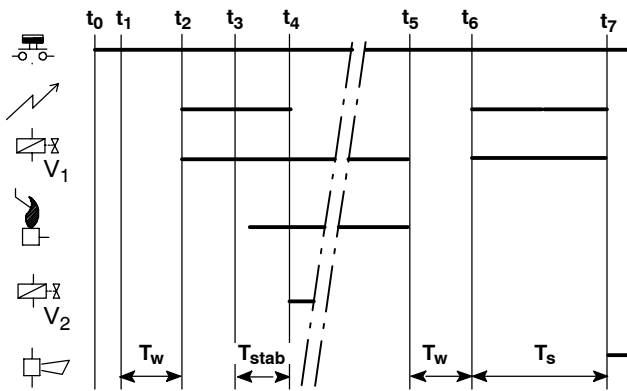

Fig. 4. Functional diagram S4560A, B, P, Q
Bild 4. Programmablauf S4560A, B, P, Q
Fig. 4. Functie diagram S4560A, B, P, Q

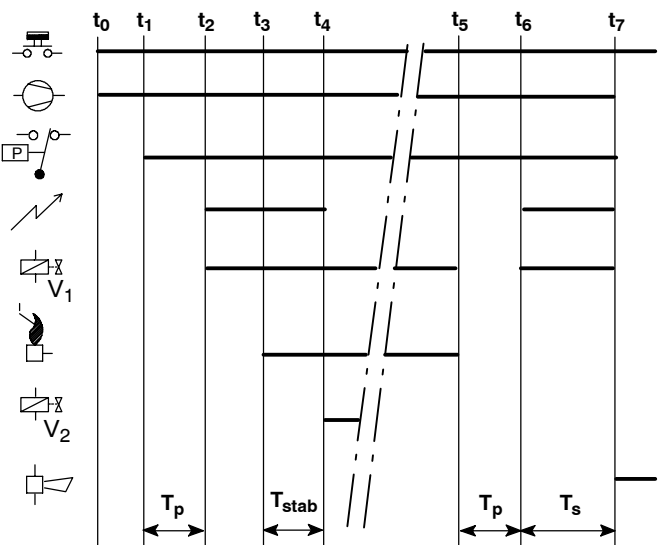

Fig. 6. Functional diagram S4560C, D, R, T
Bild 6. Programmablauf S4560C, D, R, T
Fig. 6. Functie diagram S4560C, D, R, T

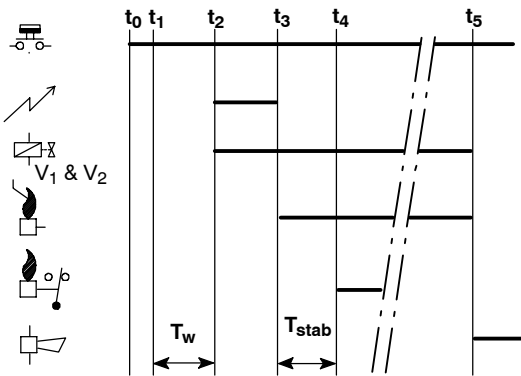
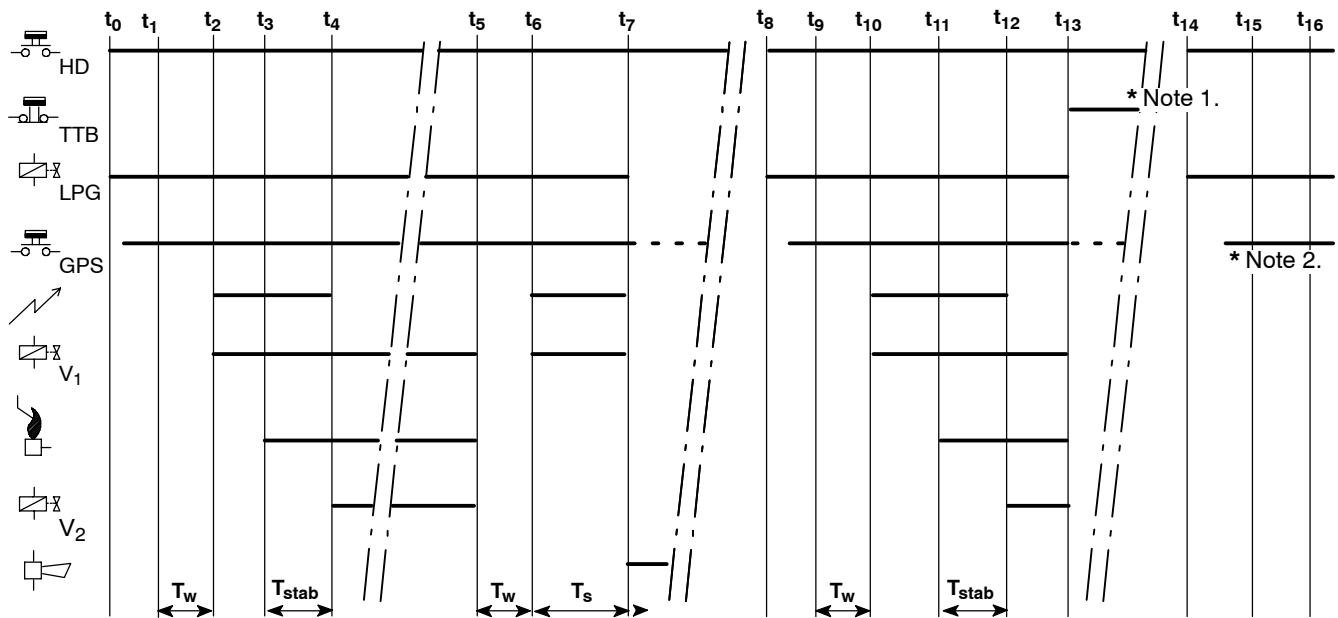

Fig. 7. Functional diagram S4560E
 Bild 7. Programmablauf S4560E
 Fig. 7. Functie diagram S4560E



- * Note 1. : S4560B, Q is waiting for manual reset on TTB switch
 S4560B, Q wartet auf Entriegelung des Rauchgasüberwachungsschalters
 S4560B, Q wacht op ontgrendeling van de TTB schakelaar
- * Note 2. : S4560B, Q is waiting for gas pressure
 S4560B, Q wartet auf Gasdruck
 S4560B, Q wacht op gasdruk

Fig. 8. Functional diagram S4560B,Q with LPG valve, GPS and TTB switch
 Bild 8. Programmanlauf S4560B,Q mit LPG Ventil, Gasdruckwächter und Rauchgasüberwachungsschalter
 Fig. 8. Functie diagram S4560B,Q met LPG gasklep, gasdruk- en TTB schakelaar

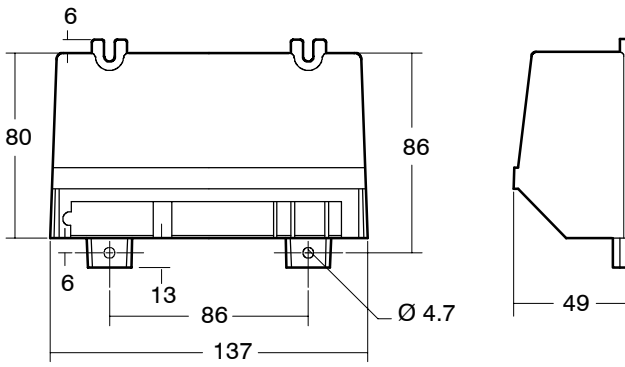

Fig. 9. Dimensions S4560
Bild 9. Abmessungen S4560
Fig. 9. Afmetingen S4560

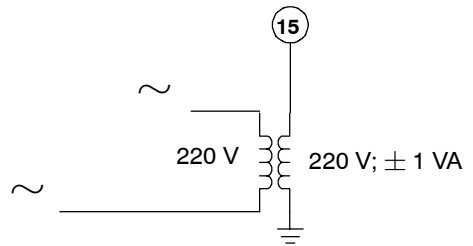

Fig. 10. Application of S4560A ... T to floating mains
Bild 10. Verwendung von S4560A ... T in einer Schwebungsnetz
Fig. 10. Toepassing van S4560A ... T in een zwevend net

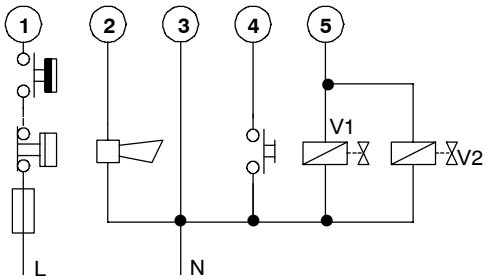
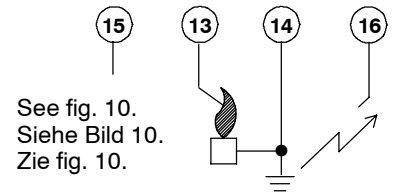

Fig. 11. Connection diagram S4560A, E, P*
Bild 11. Anschlussplan S4560A, E, P*
Fig. 11. Aansluitschema S4560A, E, P*



See fig. 10.
 Siehe Bild 10.
 Zie fig. 10.

* without reset switch
 ohne Entriegelung
 zonder ontgrendeling

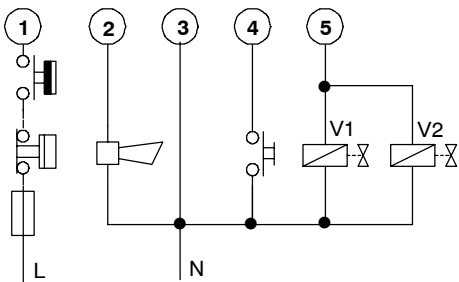
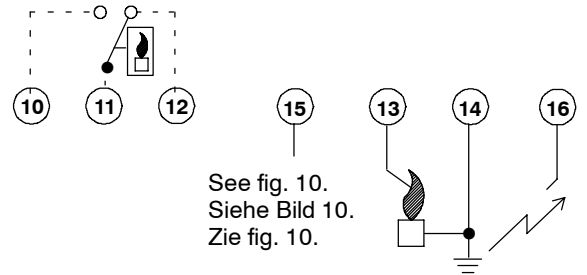

Fig. 12. Connection diagram S4560B, Q* with potential free flame relay connection
Bild 12. Anschlussplan S4560B, Q* mit spannungsfreiem Flammenrelais Anschluss
Fig. 12. Aansluitschema S4560B, Q* met spanningsvrij vlamrelais aansluiting



See fig. 10.
 Siehe Bild 10.
 Zie fig. 10.

* without reset switch
 ohne Entriegelung
 zonder ontgrendeling

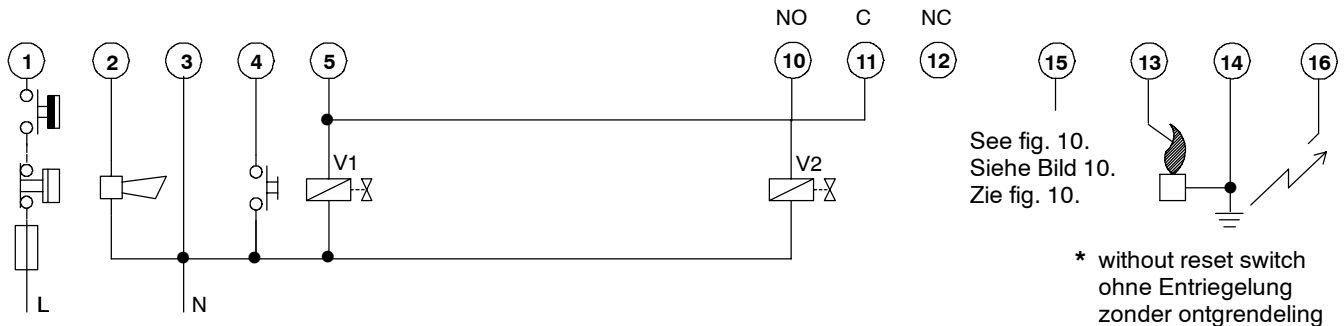

Fig. 13. Connection diagram S4560B, Q*
Bild 13. Anschlussplan S4560B, Q*
Fig. 13. Aansluitschema S4560B, Q*

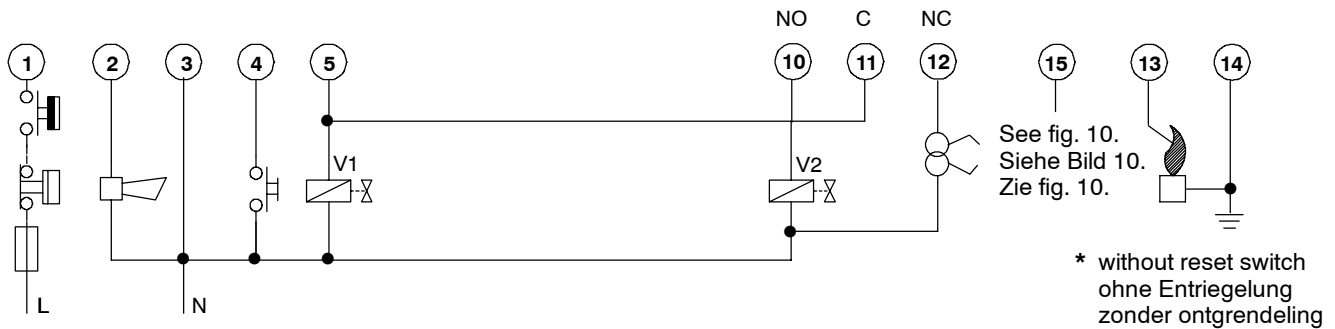
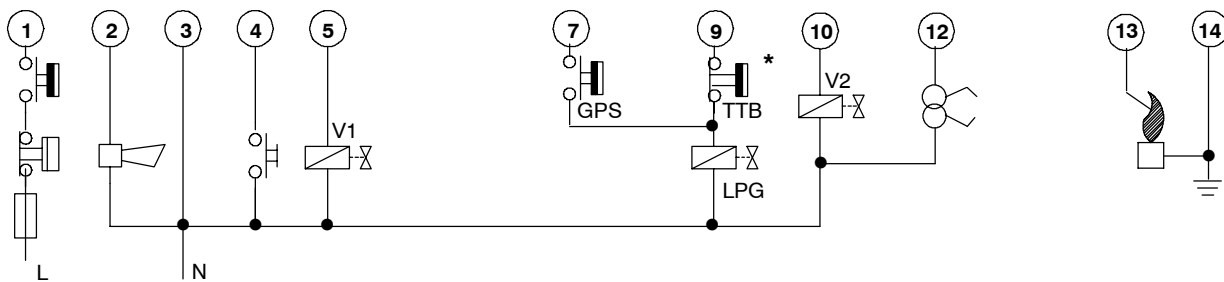
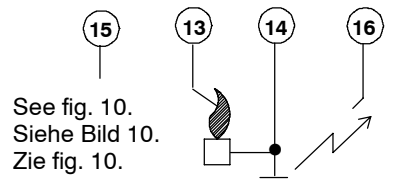
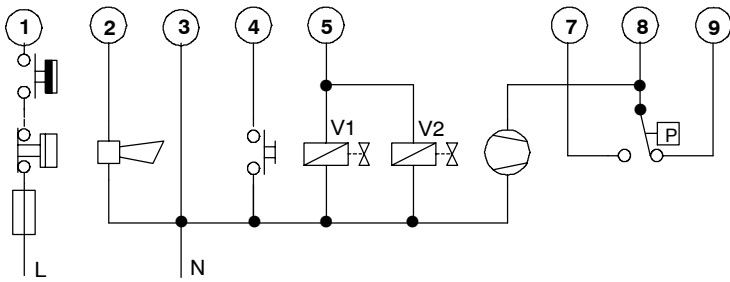

Fig. 14. Connection diagram S4560B, Q* with external ignition transformer
Bild 14. Anschlussplan S4560B, Q* mit externer Zündeinheit
Fig. 14. Aansluitschema S4560B, Q* met externe ontstektransformator



- * TTB switch must be a non volatile type and must be reset by manual operation.
- * Der Rauchgasüberwachungsschalter muss der Type "non volatile" sein und soll nur Rückstellbar sein durch Betätigung der Rückstelltaste.
- * De TTB schakelaar moet een "non volatile" type zijn en mag alleen handmatige ontgrendeld worden.

Fig. 15. Connection diagram S4560B with LPG valve, GPS, TTB switch and external ignition transformer
Bild 15. Anschlussplan S4560B mit LPG Ventil, Gasdruckwächter, Rauchgasüberwachungsschalter und externer Zündeinheit
Fig. 15. Aansluitschema S4560B met LPG gasklep, gasdruk schakelaar, TTB schakelaar en externe ontstektransformator



* without reset switch
ohne Entriegelung
zonder ontgrendeling

Fig. 16. Connection diagram S4560C, R*
Bild 16. Anschlussplan S4560C, R*
Fig. 16. Aansluitschema S4560C, R*

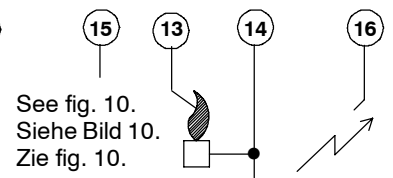
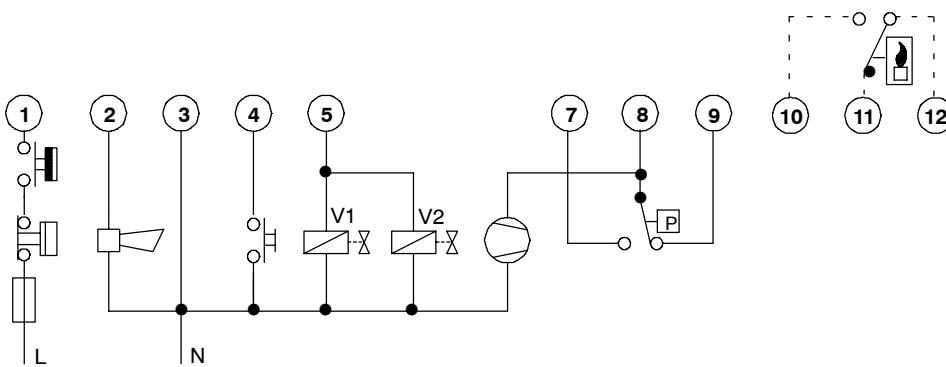

* without reset switch
ohne Entriegelung
zonder ontgrendeling

Fig. 17. Connection diagram S4560D, T* with potential free flame relay connection
Bild 17. Anschlussplan S4560D, T* mit spannungsfreiem Flammenrelais Anschluss
Fig. 17. Aansluitschema S4560D, T* met spanningsvrij vlamrelais aansluiting

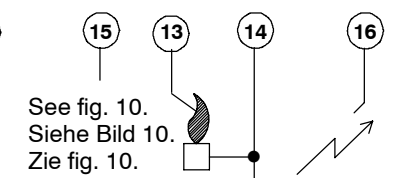
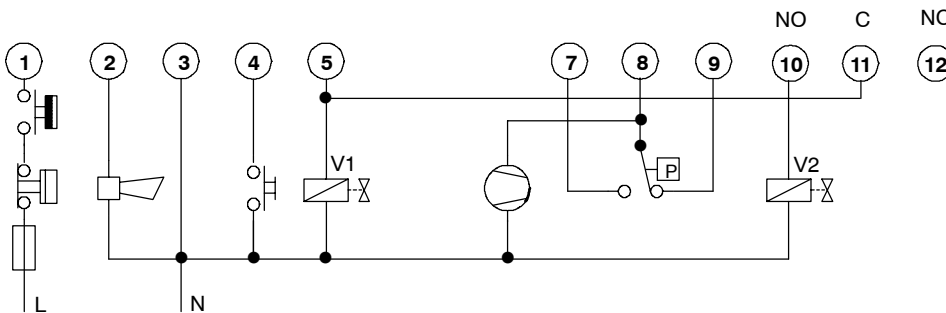

* without reset switch
ohne Entriegelung
zonder ontgrendeling

Fig. 18. Connection diagram S4560D, T*
Bild 18. Anschlussplan S4560D, T*
Fig. 18. Aansluitschema S4560D, T*

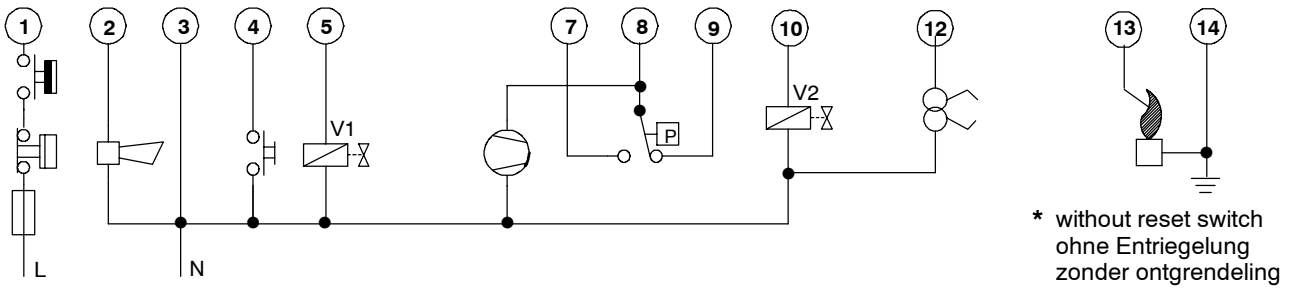

Fig. 19. Connection diagram S4560D, T* with external ignition transformer
Bild 19. Anschlussplan S4560D, T* mit externer Zündeinheit
Fig. 19. Aansluitschema S4560D, T* met externe ontstektransformer