



NJR5-ZX Series Soft Starter

1. General

NJR5-ZX series soft starter is an online soft starter, its input power voltage (main circuit voltage) is AC220V, AC380V, AC460V, AC575V and AC690V, and the rated current specification is from 15A to 1000A. With the characteristics of strong load adaptability, stable and reliable operation, etc., it is widely used in motor transmission equipment in metallurgy, petroleum, fire protection, mining, water supply, municipal, food, cement, petrochemical and other fields. It is the most ideal replacement product for a traditional star-delta starter, auto-coupling starting.

NJR5-ZX series soft starter is an AC asynchronous motor soft starter integrating power electronics technology, microprocessor technology and modern control theory technology. By controlling the three-phase parallel thyristor connected in series between the power supply and the controlled motor, the functions of soft start and soft stop of the three-phase AC asynchronous motor can be realized. This product can effectively control the starting current and the starting torque can be widely used in loads such as fans, water pumps, compressors, ball mills, and crushers.

Standards: IEC60947-4-2

2. Type designation

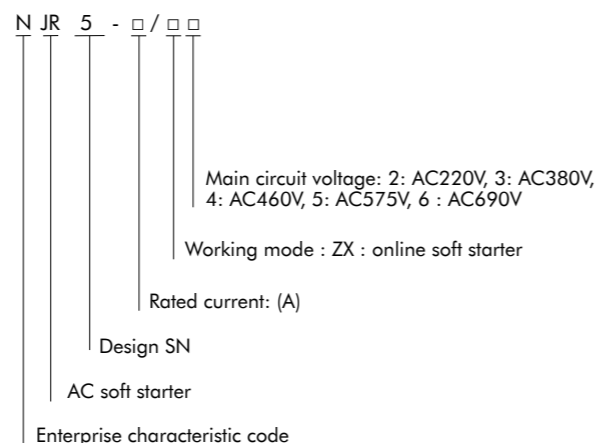

3. Operating conditions

- 3.1 Operation temperature: -10°C~+40°C, +40°C~+50°C should be derated for use, and the current will be derated by 2% for every 1°C increase.
- 3.2 Storage temperature: -25°C~+70°C.
- 3.3 Relative humidity: no more than 95% (20°C~65°C).
- 3.4 Altitude: If it exceeds 1000m, it should be used with corresponding derating. If it is above 1000m and less than 3000m, the current should be derated by 0.5% for each 100m increase. If it is above 3000m, it needs to be customized.
- 3.5 Water and dust proof: No condensation, no flammable, explosive gas, no conductive dust.
- 3.6 Shock and vibration: Do not drop the soft starter to the ground or suffer sudden impact, and do not install the soft starter where it may vibrate frequently.
- 3.7 Ventilation requirements: When the soft starter is installed in the cabinet, it is required to install an exhaust fan on the cabinet to make the cabinet ventilated smoothly.
- 3.8 Long-term storage: When the soft starter is stored for a long time, it should be energized once within two years, and then run after 1 hour.

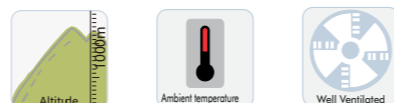

4. Technical parameters and performance

- 4.1 Power supply voltage:
 - 1) NJR5-□ / ZX2: AC220V (range: AC198V~AC264V);
 - 2) NJR5-□ / ZX3: AC380V (range: AC323V~AC437V);
 - 3) NJR5-□ / ZX4: AC460V (range: AC414V~AC504V);
 - 4) NJR5-□ / ZX5: AC575V (range: AC517V~AC633V);
 - 5) NJR5-□ / ZX6: AC690V (range: AC621V~AC759V).
- 4.2 Main power frequency: 50HZ ± 1.5Hz, 60Hz ± 1.8Hz.
- 4.3 Applicable motor: common squirrel-cage three-phase asynchronous motor
- 4.4 Pollution level: Level 3
- 4.5 Rated insulation voltage:
 - 1) NJR5-□ / ZX2 and NJR5-□ / ZX3: AC660V;
 - 2) NJR5-□ / ZX4, NR5-D/ZX5, NJR5-□ / ZX6: AC1000V.
- 4.6 Rated impulse withstand voltage: 8kV.
- 4.7 Cooling method: forced air cooling.
- 4.8 Starting frequency: The starting frequency can be set in per hour, and it should be not to exceed 10 times per hour. For the heavier load, starting frequency should be set less.
- 4.9 Soft start time: (2~60) S.
- 4.10 Soft stop time: (2~60) S.
- 4.11 Starting modes: normal current mode, enhanced current mode, normal voltage mode, enhanced voltage mode, linear torque mode, square torque mode and frequency division mode, a total of 6 types.
- 4.12 Stop mode: free stop, brake stop and voltage ramp soft stop, a total of 3 types.
- 4.13 Initial voltage: (30~70)% U_e, where U_e represents the power supply voltage.
- 4.14 Jump time: (0.0~2.0) S.
- 4.15 Jump voltage: (50~100)% U_e, where U_e represents the power supply voltage.
- 4.16 Current limiting multiple: (50~500)% I_e, where I_e represents the rated current of the motor.
- 4.17 Torque limit level: (50.0~300.0)% T_e, where T_e represents the rated torque of the motor.

5. Product features

- 5.1 Performance aspects
 - 6 starting modes: normal current mode, enhanced current mode, normal voltage mode, enhanced voltage mode, linear torque mode, square torque mode and frequency division mode, select different starting modes and starting parameter settings according to load characteristics, It can maximize the motor to achieve the best starting effect.
 - Stable kick start: When switching from the kick process to the normal start mode, the current is seamlessly and smoothly connected without sudden changes, which prolongs the life of the transmission equipment.
 - Equipped with torque control mode: real-time control of the output electromagnetic torque of the soft starter, so that the speed of the

- motor rises more smoothly during the soft start process.
- With light-load energy-saving function: when the energy-saving mode is selected, when the motor is detected to be in a light-load running state, the output voltage of the soft starter will be appropriately reduced, the motor magnetic flux will drop, the excitation current will drop, the iron loss will decrease, the stator current will decrease, and the stator copper loss will decrease. Decrease - the output power of the soft starter decreases, thereby realizing energy saving.
- Possess low-speed forward rotation and reverse rotation functions: By adjusting the trigger angle of the thyristor, the product has the switching function of low-speed forward rotation and low-speed reverse rotation, which meets some application functions, such as water pump cleaning.
- With brake stop function: by injecting direct current into the motor, it can realize fast stop and meet some occasions that require fast braking.
- Wide power supply frequency: In current mode, the power supply frequency ranges from 35Hz to 60Hz, which is more suitable for generator power supply occasions.

5.2 Functional aspects

- With secondary current limiting function: in some heavy load occasions, when the motor cannot start after the primary current limiting is adopted, the secondary current limiting can be selected (the secondary current limiting multiple is larger than the primary current limiting multiple) to start the motor, and finally the motor reaches run at full speed.
- With the function of the 2nd and 3rd motor parameters: when starting 2-3 motors in sequence, through the logic input control of the external control terminal signal IN1IN2, if the 2nd and 3rd motor parameters are selected, start and stop according to the 2nd and 3rd motor parameters And running overload protection, especially suitable for one-to-two, one-to-three applications and the application of two-speed motors.
- With a variety of protections: input phase loss, output phase loss, three-phase unbalance, operating overload, starting current limit overtime, main circuit overvoltage, main circuit undervoltage, load stall/short circuit, excessive starting time, starting times Too many faults, \ etc., effectively protect the soft starter and the motor it carries.
- It has 4 kinds of analog current output: 4mA~20mA, 0mA, 20mA, 2mA~10mA and 0mA~10mA, which are better compatible with industrial automation equipment or instrumentation equipment.
- Built-in 485 communication interface: standard Modbus protocol is adopted to realize the communication between the soft starter and the upper computer.
- The optional built-in PROFINET high-speed bus communication protocol realizes the high-speed communication function between the soft starter and the upper computer.

5.3 User aspects

- Save user cost: no need to configure bypass contactor, save cabinet space, save cable, and reduce user overall cost.
- User-friendly debugging: When the load type is selected (see F2.00 or F3.00 or F4.00), the relevant starting parameters will be automatically configured, which is convenient for user debugging.
- User-friendly installation: The wiring method is three-in and three-out, which is convenient for cabinet formation and easy installation.
- Strong operability: Chinese LCD display, friendly interface, easy parameter setting and easy operation.

5.4 Stability aspects

- The PCBA is comprehensively protected by thickened conformal paint, which greatly improves the stability of the product.



6. Selection table

Model	Rated Voltage	Rated Current	Rated Power
NJR5-15/ZX2	AC220V	15A	4kw
NJR5-22/ZX2	AC220V	22A	5.5kw
NJR5-30/ZX2	AC220V	29A	7.5kw
NJR5-37/ZX2	AC220V	36A	11kw
NJR5-44/ZX2	AC220V	42A	11kw
NJR5-60/ZX2	AC220V	57A	15kw
NJR5-74/ZX2	AC220V	70A	18.5kw
NJR5-90/ZX2	AC220V	84A	22kW
NJR5-110/ZX2	AC220V	103A	30kw
NJR5-150/ZX2	AC220V	140A	37kW
NJR5-180/ZX2	AC220V	167A	45kw
NJR5-220/ZX2	AC220V	207A	55kw
NJR5-264/ZX2	AC220V	248A	75kw
NJR5-320/ZX2	AC220V	300A	90kw
NJR5-370/ZX2	AC220V	349A	110kw
NJR5-440/ZX2	AC220V	404A	110kw
NJR5-500/ZX2	AC220V	459A	132kw
NJR5-560/ZX2	AC220V	514A	160kw
NJR5-630/ZX2	AC220V	579A	160kw
NJR5-710/ZX2	AC220V	634A	200kw
NJR5-800/ZX2	AC220V	720A	200kw
NJR5-900/ZX2	AC220V	810A	250kw
NJR5-1000/ZX2	AC220V	900A	250kw

Model	Rated Voltage	Rated Current	Rated Power
NJR5-15/ZX4	AC460V	15A	9kw
NJR5-22/ZX4	AC460V	22A	15kw
NJR5-30/ZX4	AC460V	29A	18.5kw
NJR5-37/ZX4	AC460V	36A	22kw
NJR5-44/ZX4	AC460V	42A	30kw
NJR5-60/ZX4	AC460V	57A	37kw
NJR5-74/ZX4	AC460V	70A	45kw
NJR5-90/ZX4	AC460V	84A	55kw
NJR5-110/ZX4	AC460V	103A	75kw
NJR5-150/ZX4	AC460V	140A	90kw
NJR5-180/ZX4	AC460V	167A	110kw
NJR5-220/ZX4	AC460V	207A	132kw
NJR5-264/ZX4	AC460V	248A	150kw
NJR5-320/ZX4	AC460V	300A	185kw
NJR5-370/ZX4	AC460V	349A	220kw
NJR5-440/ZX4	AC460V	404A	250kw
NJR5-500/ZX4	AC460V	459A	280kw
NJR5-560/ZX4	AC460V	514A	315kw
NJR5-630/ZX4	AC460V	579A	355kw
NJR5-710/ZX4	AC460V	634A	400kw
NJR5-800/ZX4	AC460V	720A	450kw
NJR5-900/ZX4	AC460V	810A	560kw
NJR5-1000/ZX4	AC460V	900A	560kw

Model	Rated Voltage	Rated Current	Rated Power
NJR5-15/ZX3	AC380V	15A	7.5kw
NJR5-22/ZX3	AC380V	22A	11kw
NJR5-30/ZX3	AC380V	29A	15kw
NJR5-37/ZX3	AC380V	36A	18.5kw
NJR5-44/ZX3	AC380V	42A	22kw
NJR5-60/ZX3	AC380V	57A	30kw
NJR5-74/ZX3	AC380V	70A	37kw
NJR5-90/ZX3	AC380V	84A	45kw
NJR5-110/ZX3	AC380V	103A	55kw
NJR5-150/ZX3	AC380V	140A	75kw
NJR5-180/ZX3	AC380V	167A	90kw
NJR5-220/ZX3	AC380V	207A	110kw
NJR5-264/ZX3	AC380V	248A	132kw
NJR5-320/ZX3	AC380V	300A	160kw
NJR5-370/ZX3	AC380V	349A	185kw
NJR5-440/ZX3	AC380V	404A	220kw
NJR5-500/ZX3	AC380V	459A	250kw
NJR5-560/ZX3	AC380V	514A	280kw
NJR5-630/ZX3	AC380V	579A	315kw
NJR5-710/ZX3	AC380V	634A	355kw
NJR5-800/ZX3	AC380V	720A	400kw
NJR5-900/ZX3	AC380V	810A	450kw
NJR5-1000/ZX3	AC380V	900A	500kw

Model	Rated Voltage	Rated Current	Rated Power
NJR5-15/ZX5	AC575V	15A	11kW
NJR5-22/ZX5	AC575V	22A	18.5kw
NJR5-30/ZX5	AC575V	29A	22kw
NJR5-37/ZX5	AC575V	36A	30kw
NJR5-44/ZX5	AC575V	42A	30kw
NJR5-60/ZX5	AC575V	57A	45kw
NJR5-74/ZX5	AC575V	70A	55kw
NJR5-90/ZX5	AC575V	84A	75kw
NJR5-110/ZX5	AC575V	103A	90kw
NJR5-150/ZX5	AC575V	140A	110kw
NJR5-180/ZX5	AC575V	167A	132kw
NJR5-220/ZX5	AC575V	207A	160kw
NJR5-264/ZX5	AC575V	248A	185kw
NJR5-320/ZX5	AC575V	300A	250kw
NJR5-370/ZX5	AC575V	349A	280kw
NJR5-440/ZX5	AC575V	404A	315kw
NJR5-500/ZX5	AC575V	459A	355kw
NJR5-560/ZX5	AC575V	514A	400kw
NJR5-630/ZX5	AC575V	579A	450kw
NJR5-710/ZX5	AC575V	634A	500kw
NJR5-800/ZX5	AC575V	720A	560kw
NJR5-900/ZX5	AC575V	810A	630kw
NJR5-1000/ZX5	AC575V	900A	800kw



Model	Rated Voltage	Rated Current	Rated Power
NJR5-15/ZX6	AC690V	15A	11kw
NJR5-22/ZX6	AC690V	22A	18.5kw
NJR5-30/ZX6	AC690V	29A	22kw
NJR5-37/ZX6	AC690V	36A	30kw
NJR5-44/ZX6	AC690V	42A	37kw
NJR5-60/ZX6	AC690V	57A	55kw
NJR5-74/ZX6	AC690V	70A	75kw
NJR5-90/ZX6	AC690V	84A	90kw
NJR5-110/ZX6	AC690V	103A	110kw
NJR5-150/ZX6	AC690V	140A	132kw
NJR5-180/ZX6	AC690V	167A	160kw
NJR5-220/ZX6	AC690V	207A	200kw
NJR5-264/ZX6	AC690V	248A	250kw
NJR5-320/ZX6	AC690V	300A	315kw
NJR5-370/ZX6	AC690V	349A	355kw
NJR5-440/ZX6	AC690V	404A	400kw
NJR5-500/ZX6	AC690V	459A	400kw
NJR5-560/ZX6	AC690V	514A	500kw
NJR5-630/ZX6	AC690V	579A	560kw
NJR5-710/ZX6	AC690V	634A	630kw
NJR5-800/ZX6	AC690V	720A	710kw
NJR5-900/ZX6	AC690V	810A	800kw
NJR5-1000/ZX6	AC690V	900A	900kw

7. Basic Wiring Diagram

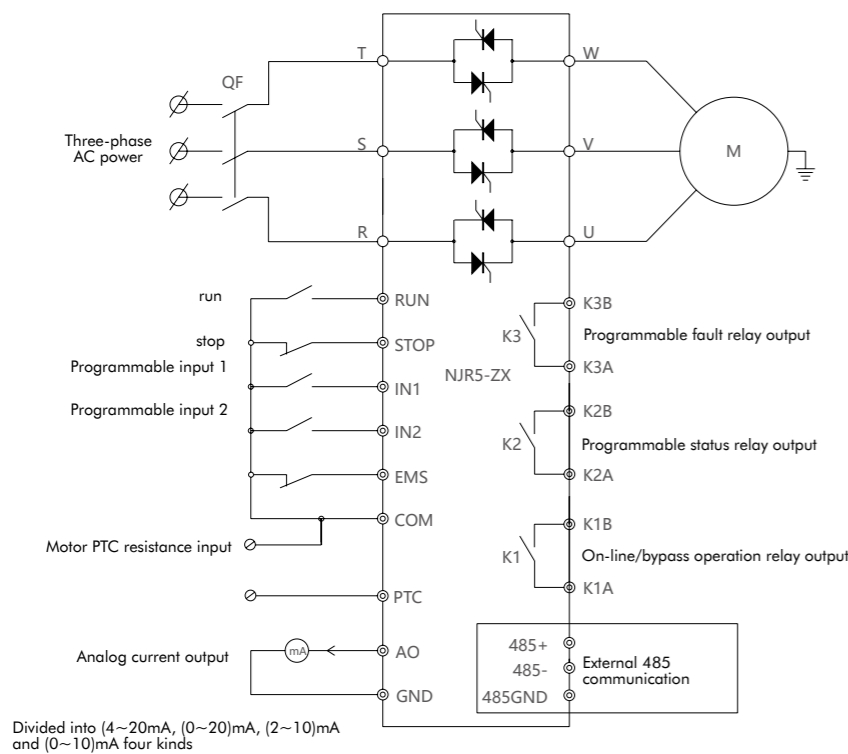

Note: When using the external control terminal to control start and stop, when the STOP terminal and the COM terminal are in the closed state, after the product is powered on, it must be detected that the RUN terminal and the COM terminal have changed from open to closed before it is considered to have received a valid signal. Start command, if the RUN terminal and COM terminal are always in the closed state when the power is turned on, the effective start command cannot be received.

8. Terminal definition

8.1 Definition of main circuit terminals

R / S / T	The input terminal of the three-phase AC power supply is also the input terminal of the soft starter
U/V/W	The output terminal of the soft starter is also the input terminal of the three-phase asynchronous motor

8.2 Definition of external control terminals

Terminal name	Terminal definition	Description
K1A, K1B	On-line/bypass relay K1 (normally open)	Contact capacity: 5A/250VAC. K1A, K1B terminals become closed when the soft starter switches to online operation or bypass operation state.
K2A, K2B	Programmable status relay K2 (normally open)	Contact capacity: 3A/250VAC. determined by function parameters F5.00 and F5.13. When the tens digit of F5.00 is 0, it means that the terminal K2A and K2B are in the active state when they are closed; when it is 1, it means that the terminal K2A and K2B are in the active state when they are disconnected. for example: If the tens place of F5.00 is set to 0, and F5.13 is set to 2 (online/bypass state), when the soft starter enters on-line/bypass operation state, K2A and K2B terminals are closed, while in other working states Both K2A and K2B terminals are disconnected; when the tens place of F5.00 is set to 1, F5.13 is set to 2 (online/bypass state), when the soft starter enters on-line/bypass operation state, K2A and K2B terminals Open, and in any other working state, K2A, K2B terminals are closed.
K3A, K3B	Programmable status relay K3 (normally open)	Contact capacity: 3A/250VAC. This function is determined by function parameters F5.00 and F5.14. When the ones digit of F5.00 is 0, it means that the terminal K3A and K3B are in the active state; when it is 1, it means that the terminal K3A and K3B are in the active state. for example: If the unit digit of F5.00 is set to 0, and F5.14 is set to 0 (any fault or alarm), when any fault or alarm occurs to the soft starter, K3A and K3B terminals are closed, and when there is no fault or alarm, K3A, K3B terminal is disconnected; when F5.00 When the ones place is set to 1, F5.14 is set to 0 (any fault or alarm), when the soft starter has any fault or alarm, K3A and K3B terminals are disconnected, and when there is no fault or alarm, both K3A and K3B terminals are closed.
RUN	Start terminal RUN	Use COM as the reference point. When the external control start is allowed, when the RUN terminal and the STOP terminal are closed at the same time, and the closing time is greater than the setting value of F5.07 and F5.09, a start command will be issued; when the STOP terminal is disconnected, and the disconnection time is greater than F5. When the value of 10 is set, a shutdown command will be issued. Note: This terminal is a dry contact, and AC signals cannot be connected or introduced.
STOP	Stop terminal STOP	
IN1	Programmable input terminal IN1	Take COM as the reference point. The function is determined by parameter F5.01, and the factory default value is 1 (external fault) Note: This terminal is a dry contact, and AC signals cannot be connected or introduced.
IN2	Programmable input terminal IN2	Take COM as the reference point. The function is determined by parameter F5.02, and the factory default value is 4 (fault reset). Note: This terminal is a dry contact, and AC signals cannot be connected or introduced.
EMS	Momentary stop terminal EMS	Take COM as the reference point. When it is detected that the EMS terminal is disconnected from the COM terminal, it will report a "momentary power failure terminal open circuit" fault. Note: This terminal is a dry contact, and AC signals cannot be connected or introduced.
COM	External control common terminal COM	Signal input common for terminals RUN, STOP, IN1, IN2, EMS and PTC
PTC	Motor input terminal PTC	Used for thermal protection of motors. The total resistance of the motor temperature sensor circuit: 2000~750Ω at 25°C, when the total resistance is greater than 3.1kΩ, it will report "motor overheating failure", and when the total resistance is less than 1.5kΩ, the motor is overheated and the product returns to the ready state.
AO	Analog output terminal AO	Use GND as a reference point. The analog AO output type is determined by F6.00, including four output types of 4mA~20mA, 0mA~20mA, 2mA~10mA and 0mA~10mA. The factory default value is 4mA~20mA. The analog AO output function is determined by F6.01, including motor current Max=500%le, motor current Max=200%le, motor current Max=100%le, main circuit voltage V, soft starter temperature °C, power factor and electromagnetic torque [100%], the factory default value is motor current Max=200%le.
GND	Internal chip working ground GND	The working ground of the main chip is also the ground of the analog output AO.
485+ 485- 485GND	485 communication terminal 485+ 485 communication terminal 485- 485 communication terminal 485GND	485+ is connected to the differential positive end of the host computer; 485-Connect to the differential negative terminal of the host computer; 485GND is connected to the ground of the differential power supply of the upper computer, so that the communication ground of the soft starter is directly connected with the communication ground of the upper computer, making the communication more reliable.

9. Outline and installation dimensions

9.1 Outline and installation dimensions of the operation panel



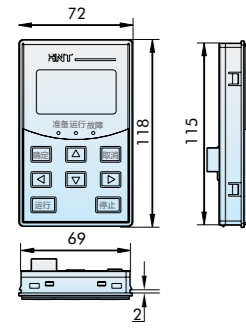

9.2 Outline and installation dimensions of the support plate of the operation panel

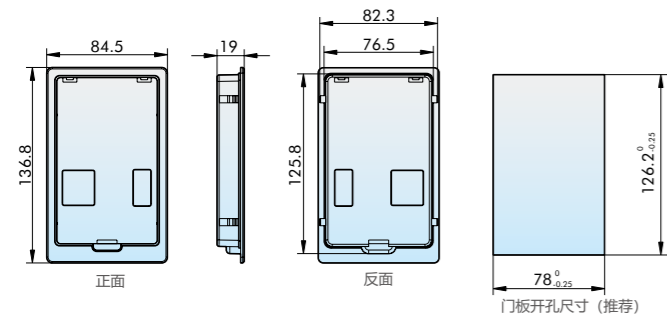

Note: NJR5-ZX products with a rated current greater than 90A are equipped with a support plate for the operation panel

9.3 Outline and installation dimensions of the whole machine

9.3.1 NJR5-15/ZX2~NJR5-90/ZX2, NJR5-15/ZX3~NJR5-90/ZX3, NJR5-15/ZX4~NJR5-90/ZX4, NJR5-15/ZX5~NJR5-90/ZX5 And NJR5-15/ZX6~NJR5-90/ZX6 overall appearance and installation dimensions.

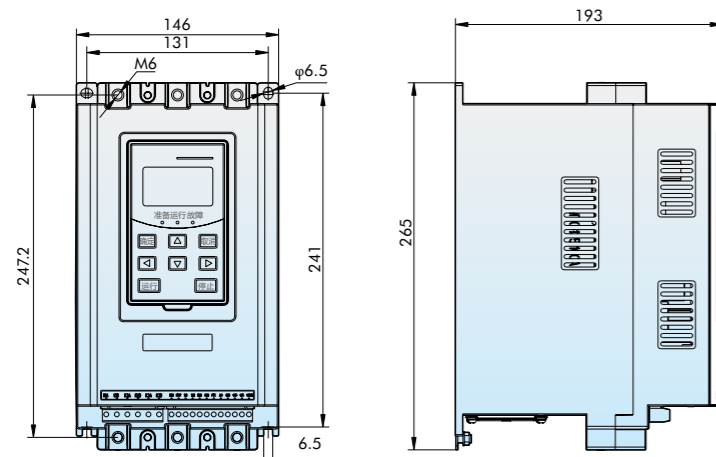

Model	Rated Voltage	Rated Current	Matched Motor Power	Net Weight(Kg)	Gross Weight(Kg)
NJR5-15/ZX2	AC220V	15A	4kw	6.2	6.7
NJR5-22/ZX2	AC220V	22A	5.5kw	6.2	6.7
NJR5-30/ZX2	AC220V	29A	7.5kw	6.2	6.7
NJR5-37/ZX2	AC220V	36A	11kw	6.2	6.7
NJR5-44/ZX2	AC220V	42A	11kw	6.2	6.7
NJR5-60/ZX2	AC220V	57A	15kw	6.2	6.7
NJR5-74/ZX2	AC220V	70A	18.5kw	6.2	6.7
NJR5-90/ZX2	AC220V	84A	22kW	6.2	6.7
NJR5-15/ZX3	AC380V	15A	7.5kw	6.2	6.7
NJR5-22/ZX3	AC380V	22A	11kw	6.2	6.7
NJR5-30/ZX3	AC380V	29A	15kw	6.2	6.7
NJR5-37/ZX3	AC380V	36A	18.5kw	6.2	6.7
NJR5-44/ZX3	AC380V	42A	22kw	6.2	6.7
NJR5-60/ZX3	AC380V	57A	30kw	6.2	6.7
NJR5-74/ZX3	AC380V	70A	37kw	6.2	6.7
NJR5-90/ZX3	AC380V	84A	45kw	6.2	6.7
NJR5-15/ZX4	AC460V	15A	9kw	6.2	6.7
NJR5-22/ZX4	AC460V	22A	15kw	6.2	6.7
NJR5-30/ZX4	AC460V	29A	18.5kw	6.2	6.7
NJR5-37/ZX4	AC460V	36A	22kW	6.2	6.7
NJR5-44/ZX4	AC460V	42A	30kw	6.2	6.7
NJR5-60/ZX4	AC460V	57A	37kw	6.2	6.7
NJR5-74/ZX4	AC460V	70A	45kw	6.2	6.7
NJR5-90/ZX4	AC460V	84A	55kw	6.2	6.7
NJR5-15/ZX5	AC575V	15A	11kW	6.2	6.7
NJR5-22/ZX5	AC575V	22A	18.5kw	6.2	6.7
NJR5-30/ZX5	AC575V	29A	22kw	6.2	6.7
NJR5-37/ZX5	AC575V	36A	30kw	6.2	6.7
NJR5-44/ZX5	AC575V	42A	30kw	6.2	6.7
NJR5-60/ZX5	AC575V	57A	45kw	6.2	6.7
NJR5-74/ZX5	AC575V	70A	55kw	6.2	6.7
NJR5-90/ZX5	AC575V	84A	75kw	6.2	6.7
NJR5-15/ZX6	AC690V	15A	11kw	6.2	6.7
NJR5-22/ZX6	AC690V	22A	18.5kw	6.2	6.7
NJR5-30/ZX6	AC690V	29A	22kw	6.2	6.7
NJR5-37/ZX6	AC690V	36A	30kw	6.2	6.7
NJR5-44/ZX6	AC690V	42A	37kw	6.2	6.7
NJR5-60/ZX6	AC690V	57A	55kw	6.2	6.7
NJR5-74/ZX6	AC690V	70A	75kw	6.2	6.7
NJR5-90/ZX6	AC690V	84A	90kw	6.2	6.7

9.3.2 NJR5-110/ZX2~NJR5-150/ZX2, NJR5-110/ZX3~NJR5-150/ZX3, NJR5-110/ZX4~NJR5-150/ZX4, NJR5-110/ZX5~NJR5-150/ZX5 And NJR5-110/ZX6~NJR5-150/ZX6 overall appearance and installation dimensions.

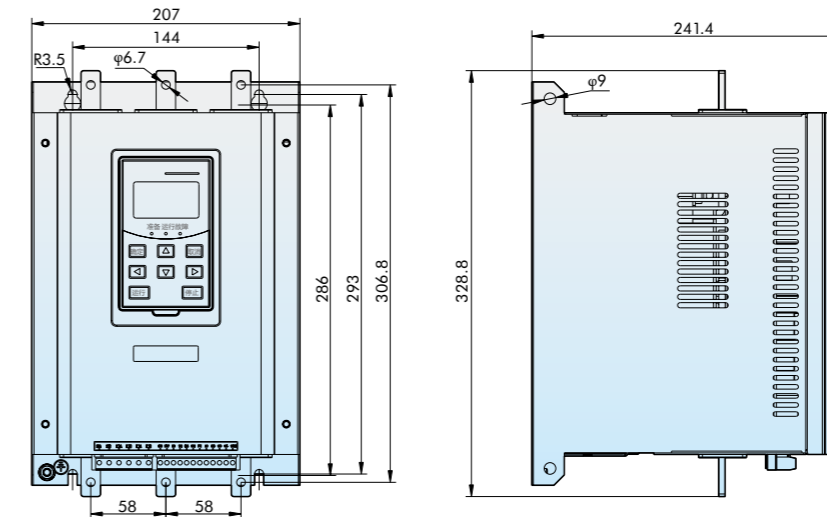

Model	Rated Voltage	Rated Current	Matched Motor Power	Net Weight(Kg)	Gross Weight(Kg)
NJR5-110/ZX2	AC220V	103A	30kw	10.2	10.7
NJR5-150/ZX2	AC220V	140A	37kW	10.2	10.7
NJR5-110/ZX3	AC380V	103A	55kw	10.2	10.7
NJR5-150/ZX3	AC380V	140A	75kw	10.2	10.7
NJR5-110/ZX4	AC460V	103A	75kw	10.2	10.7
NJR5-150/ZX4	AC460V	140A	90kw	10.2	10.7
NJR5-110/ZX5	AC575V	103A	90kw	10.2	10.7
NJR5-150/ZX5	AC575V	140A	110kw	10.2	10.7
NJR5-110/ZX6	AC690V	103A	110kw	10.2	10.7
NJR5-150/ZX6	AC690V	140A	132kw	10.2	10.7

9.3.3 NJR5-180/ZX2~NJR5-370/ZX2 , NJR5-180/ZX3~NJR5-370/ZX3 , NJR5-180/ZX4~NJR5-370/ZX4 , NJR5-180/ZX5~NJR5-370/ Outline and installation dimensions of ZX5 and NJR5-180/ZX6~NJR5-370/ZX6.

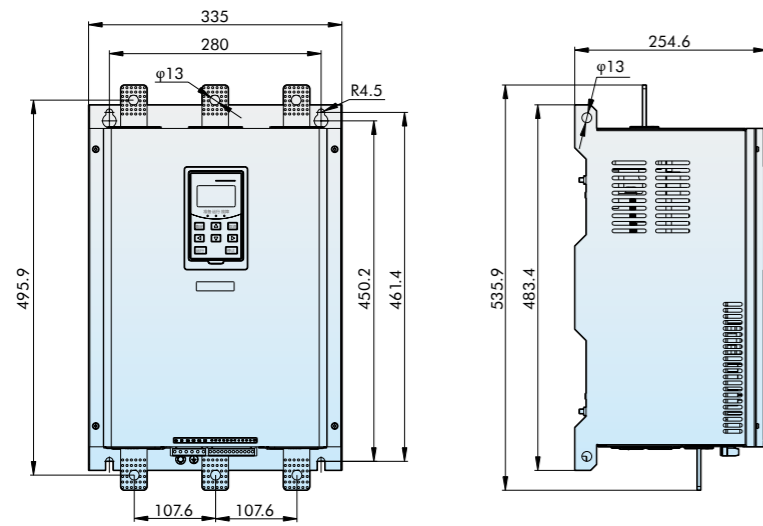

Model	Rated Voltage	Rated Current	Matched Motor Power	Net Weight(Kg)	Gross Weight(Kg)
NJR5-180/ZX2	AC220V	167A	45kw	24.5	26.5
NJR5-220/ZX2	AC220V	207A	55kw	24.5	26.5
NJR5-264/ZX2	AC220V	248A	75kw	24.5	26.5
NJR5-320/ZX2	AC220V	300A	90kw	24.5	26.5
NJR5-370/ZX2	AC220V	349A	110kw	24.5	26.5
NJR5-180/ZX3	AC380V	167A	90kw	24.5	26.5
NJR5-220/ZX3	AC380V	207A	110kw	24.5	26.5
NJR5-264/ZX3	AC380V	248A	132kw	24.5	26.5
NJR5-320/ZX3	AC380V	300A	160kw	24.5	26.5
NJR5-370/ZX3	AC380V	349A	185kw	24.5	26.5
NJR5-180/ZX4	AC460V	167A	110kw	24.5	26.5
NJR5-220/ZX4	AC460V	207A	132kw	24.5	26.5
NJR5-264/ZX4	AC460V	248A	150kw	24.5	26.5
NJR5-320/ZX4	AC460V	300A	185kw	24.5	26.5
NJR5-370/ZX4	AC460V	349A	220kw	24.5	26.5
NJR5-180/ZX5	AC575V	167A	132kw	24.5	26.5
NJR5-220/ZX5	AC575V	207A	160kw	24.5	26.5
NJR5-264/ZX5	AC575V	248A	185kw	24.5	26.5
NJR5-320/ZX5	AC575V	300A	250kw	24.5	26.5
NJR5-370/ZX5	AC575V	349A	280kw	24.5	26.5
NJR5-180/ZX6	AC690V	167A	160kw	24.5	26.5
NJR5-220/ZX6	AC690V	207A	200kw	24.5	26.5
NJR5-264/ZX6	AC690V	248A	250kw	24.5	26.5
NJR5-370/ZX6	AC690V	300A	315kw	24.5	26.5
NJR5-370/ZX6	AC690V	349A	355kw	24.5	26.5

9.3.4 NJR5-440/ZX2~NJR5-710/ZX2 , NJR5-440/ZX3~NJR5-710/ZX3 , NJR5-440/ZX4~NJR5-710/ZX4 , NJR5-440/ZX5~NJR5-710 /ZX5 and NJR5-440/ZX6~NJR5-710/ZX6 overall appearance and installation dimensions.

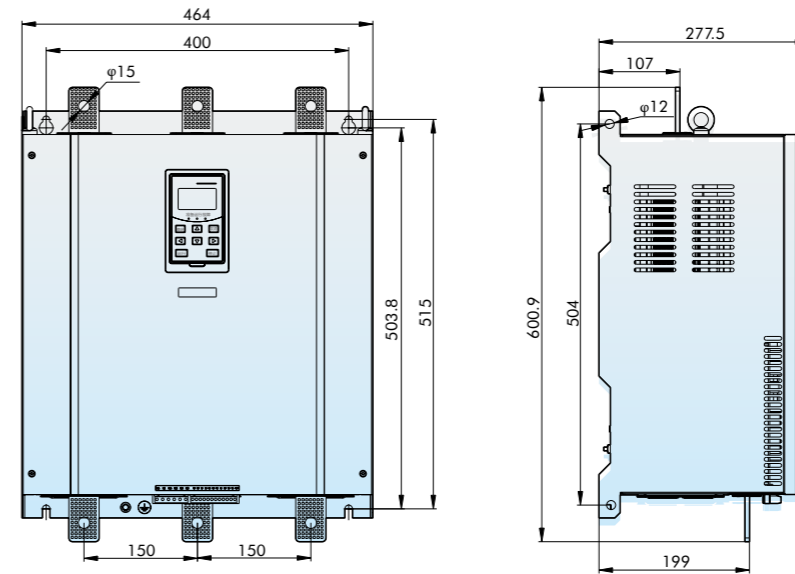

Model	Rated Voltage	Rated Current	Matched Motor Power	Net Weight(Kg)	Gross Weight(Kg)
NJR5-440/ZX2	AC220V	404A	110kw	39.6	42.6
NJR5-500/ZX2	AC220V	459A	132kw	39.6	42.6
NJR5-560/ZX2	AC220V	514A	160kw	39.6	42.6
NJR5-630/ZX2	AC220V	579A	160kw	39.6	42.6
NJR5-710/ZX2	AC220V	634A	200kw	39.6	42.6
NJR5-440/ZX3	AC380V	404A	220kw	39.6	42.6
NJR5-500/ZX3	AC380V	459A	250kw	39.6	42.6
NJR5-560/ZX3	AC380V	514A	280kw	39.6	42.6
NJR5-630/ZX3	AC380V	579A	315kw	39.6	42.6
NJR5-710/ZX3	AC380V	634A	355kw	39.6	42.6
NJR5-440/ZX4	AC460V	404A	250kw	39.6	42.6
NJR5-500/ZX4	AC460V	459A	280kw	39.6	42.6
NJR5-560/ZX4	AC460V	514A	315kw	39.6	42.6
NJR5-630/ZX4	AC460V	579A	355kw	39.6	42.6
NJR5-710/ZX4	AC460V	634A	400kw	39.6	42.6
NJR5-440/ZX5	AC575V	404A	315kw	39.6	42.6
NJR5-500/ZX5	AC575V	459A	355kw	39.6	42.6
NJR5-560/ZX5	AC575V	514A	400kw	39.6	42.6
NJR5-630/ZX5	AC575V	579A	450kw	39.6	42.6
NJR5-710/ZX5	AC575V	634A	500kw	39.6	42.6
NJR5-440/ZX6	AC690V	404A	400kw	39.6	42.6
NJR5-500/ZX6	AC690V	459A	400kw	39.6	42.6
NJR5-560/ZX6	AC690V	514A	500kw	39.6	42.6
NJR5-630/ZX6	AC690V	579A	560kw	39.6	42.6
NJR5-710/ZX6	AC690V	634A	630kw	39.6	42.6

9.3.5 NJR5-800/ZX2~NJR5-1000/ZX2 , NJR5-800/ZX3~NJR5-1000/ZX3 , NJR5-800/ZX4~NJR5-1000/ZX4 , NJR5-800/ZX5~NJR5-1000/ZX5 And NJR5-800/ZX6~NJR5-1000/ZX6 overall appearance and installation dimensions.



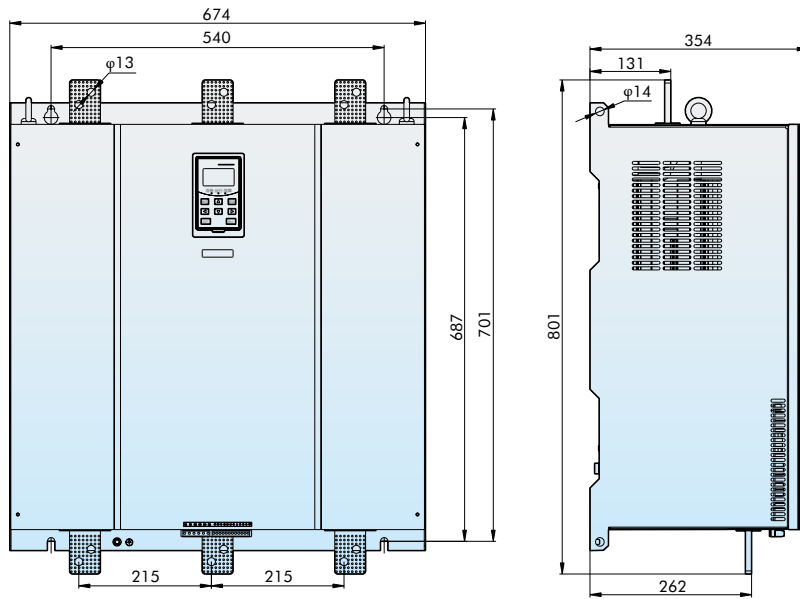

Model	Rated Voltage	Rated Current	Matched Motor Power	Net Weight(Kg)	Gross Weight(Kg)
NJR5-800/ZX2	AC220V	720A	200kw	80	84
NJR5-900/ZX2	AC220V	810A	250kw	80	84
NJR5-1000/ZX2	AC220V	900A	250kw	80	84
NJR5-800/ZX3	AC380V	720A	400kw	80	84
NJR5-900/ZX3	AC380V	810A	450kw	80	84
NJR5-1000/ZX3	AC380V	900A	500kw	80	84
NJR5-800/ZX4	AC460V	720A	450kw	80	84
NJR5-900/ZX4	AC460V	810A	560kw	80	84
NJR5-1000/ZX4	AC460V	900A	560kw	80	84
NJR5-800/ZX5	AC575V	720A	560kw	80	84
NJR5-900/ZX5	AC575V	810A	630kw	80	84
NJR5-1000/ZX5	AC575V	900A	800kw	80	84
NJR5-800/ZX6	AC690V	720A	710kw	80	84
NJR5-900/ZX6	AC690V	810A	800kw	80	84
NJR5-1000/ZX6	AC690V	900A	900kw	80	84

10. Ordering Information

10.1 When ordering, please select the required model and specification according to the description of the model and its meaning.

Example: The power level of the grid is AC380V, the power of the controlled motor is 45kW, and the rated current is 84A. It is necessary to use the soft starter together with the soft starter cabinet or power distribution cabinet.

The order model is: NJR5-90/ZX3

Example: The power level of the grid is AC690V, the power of the controlled motor is 90kw, and the rated current is 84A. It is necessary to use the soft starter together with the soft starter cabinet or power distribution cabinet.

The order model is: NJR5-90/ZX 6

10.2 When using a soft starter for a motor with more than four poles, it is recommended to use a larger size.

10.3 When using a soft starter for a two-pole motor, due to the large starting current, please set the parameters correctly according to the instruction manual before using it.

10.4 For occasions with heavy loads, it is recommended to use a soft starter with a larger gear.