

G5-series AC Servo Drives with Built-in EtherCAT Communications

R88D-KN□-ECT

Contents



- Ordering Information
- Specifications
 - General Specifications
 - Characteristics
 - Servo Drives with Single-phase 100 VAC Input Power
 - Servo Drives with Single-phase or Three-phase 200 VAC Input Power
 - Servo Drives with Three-phase 400 VAC Input Power
 - EtherCAT Communication Specifications
- Version Information
- Names and Functions
 - Servo Drive Part Names
 - Functions
- Dimensions

Ordering Information

Refer to the Ordering Information.

Specifications

General Specifications

Item		Specifications	
Ambient operating temperature and operating humidity		0 to 55°C, 85% max. (with no condensation)	
Storage ambient temperature and humidity		-20 to 65°C, 85% max. (with no condensation)	
Operating and storage atmosphere		No corrosive gases	
Vibration resistance		10 to 60 Hz and at an acceleration of 5.88 m/s ² or less (Not to be run continuously at a resonance point)	
Insulation resistance		Between power supply terminals/power terminals and FG terminal: 0.5 MΩ min. (at 500 VDC)	
Dielectric strength		Between power supply/power line terminals and FG terminal: 1,500 VAC for 1 min at 50/60 Hz	
Protective structure		Built into panel	
International standard	EU Directives and UK legislation	EMC	EN 55011, EN 61000-6-2, IEC 61800-3
		Low Voltage	EN 61800-5-1
		Machinery	EN954-1 (Cat.3), EN ISO 13849-1: 2008 (Category 3) (PLc,d), ISO 13849-1: 2006 (Category 3) (PLc,d), EN61508 (SIL2), EN62061 (SIL2), EN61800-5-2 (STO), IEC61326-3-1 (SIL2)
	UL standards		UL 508C
	CSA standards		CSA C22.2 No. 14
Korean Radio Regulations (KC)		Certified	

Note: 1. The above items reflect individual evaluation testing. The results may differ under compound conditions.

Note: 2. Always disconnect all connections to the Servo Drive before you perform insulation resistance tests on it. If you perform an insulation resistance test while the Servo Drive is connected, the Servo Drive may be damaged. Never perform dielectric strength tests on the Servo Drive. Failure to follow this precaution may result in damaging internal elements.

Note: 3. Some Servo Drive parts will require maintenance. For details, refer to the G5 series USER'S MANUAL. Confirm the Manual No. that is listed in Related Manuals.

Characteristics

● Servo Drives with 100 VAC Input Power for Single-phase input type

Item			R88D-KNA5L-ECT	R88D-KN01L-ECT	R88D-KN02L-ECT	R88D-KN04L-ECT
Continuous output current (rms)			1.2A	1.7A	2.5A	4.6A
Input power supply	Main circuit	Power supply capacity	0.4KVA	0.4KVA	0.5KVA	0.9KVA
		Power supply voltage	Single-phase 100 to 120 VAC (85 to 132 V) 50/60 Hz			
		Rated current	1.7A	2.6A	4.3A	7.6A
		Heat value*1	11W	16.6W	21W	25W
	Control circuit	Power supply voltage	Single-phase 100 to 120 VAC (85 to 132 V) 50/60 Hz			
		Heat value*1	4W	4W	4W	4W
Weight			Approx. 0.8kg	Approx. 0.8kg	Approx. 1.0kg	Approx. 1.6kg
Maximum applicable motor capacity			50W	100W	200W	400 W
Applicable Servomotor (R88M-)	3,000 r/min Servomotors	INC	K05030H	K10030L	K20030L	K40030L
		ABS	K05030T	K10030S	K20030S	K40030S
	2,000 r/min Servomotors	ABS	-	-	-	-
		ABS	-	-	-	-

*1. The heat value is given for rated operation.

● Servo Drives with 200 VAC Input Power for Single-phase/Three-phase input type

Item			R88D-KN01H-ECT	R88D-KN02H-ECT	R88D-KN04H-ECT	R88D-KN08H-ECT	R88D-KN10H-ECT	R88D-KN15H-ECT
Continuous output current (rms)			1.2A	1.6A	2.6A	4.1A	5.9A	9.4A
Input power supply	Main circuit	Power supply capacity	0.5KVA	0.5KVA *1	0.9KVA	1.3KVA	1.8KVA	2.3KVA
		Power supply voltage	Single-phase or 3-phase 200 to 240 VAC (170 to 264 V) 50/60 Hz					
		Rated current	1.6/0.9A *1	2.4/1.3A *1	4.1/2.4A *1	6.6/3.6A *1	9.1/5.2A *1	14.2/8.1A *1
		Heat value*2	14.3/13.7W*1	23/19W *1	33/24W *1	30/35.5W *1	57/49W *1	104/93W*1
	Control circuit	Power supply voltage	Single-phase 200 to 240 VAC (170 to 264 V) 50/60 Hz					
		Heat value*2	4W	4W	4W	4W	7W	7W
Weight			Approx. 0.8kg	Approx. 0.8kg	Approx. 1.0kg	Approx. 1.6kg	Approx. 1.8kg	Approx. 1.8kg
Maximum applicable motor capacity			100W	200W	400W	750W	1kW	1.5kW
Applicable Servomotor (R88M-)	3,000 r/min Servomotors	INC	K05030H K10030H	K20030H	K40030H	K75030H	-	K1K030H K1K530H
		ABS	K05030T K10030T	K20030T	K40030T	K75030T	-	K1K030T K1K530T
	2,000 r/min Servomotors	INC	-	-	-	-	K1K020H	K1K520H
		ABS	-	-	-	-	K1K020T	K1K520T
	1,000 r/min Servomotors	INC	-	-	-	-	-	K90010H
		ABS	-	-	-	-	-	K90010T

*1. The first value is for single-phase input power and the second value is for 3-phase input power.

*2. The heat value is given for rated operation.

AC Servomotor/Drive G5-series

● Servo Drives with 200 VAC Input Power for Three-phase input type

Item			R88D-KN20H-ECT	R88D-KN30H-ECT	R88D-KN50H-ECT	R88D-KN75H-ECT	R88D-KN150H-ECT	
Continuous output current (rms)			13.4A	18.7A	33.0A	44.0A	66.1A	
Input power supply	Main circuit	Power supply capacity	3.3KVA	4.5KVA	7.5KVA	11.0KVA	22.0KVA	
		Power supply voltage	3-phase 200 to 230 VAC (170 to 253 V) 50/60 Hz				3-phase 200 to 230 VAC (170 to 253V) 50/60Hz 280 to 325 VDC (238 to 357V)	
		Rated current	11.8A	15.1A	21.6A	32.0A	58.0A	
		Heat value*1	139W	108W	328W	381W	720W	
	Control circuit	Power supply voltage	Single-phase 200 to 230 VAC (170 to 253 V) 50/60 Hz				Single-phase 200 to 230 VAC (170 to 253V) 50/60Hz 280 to 325 VDC (238 to 357V)	
		Heat value*1	10W	13W	13W	15W	17W	
Weight			Approx. 2.7kg	Approx. 4.8kg	Approx. 4.8kg	Approx. 13.5kg	Approx. 21.0kg	
Maximum applicable motor capacity			2kW	3kW	5kW	7.5kW	15kW	
Applicable Servomotor (R88M-)	3,000 r/min Servomotors	INC	K2K030H	K3K030H	K4K030H K5K030H	-	-	
		ABS	K2K030T	K3K030T	K4K030T K5K030T	-	-	
	2,000 r/min, 1,500 r/min Servomotors	INC	K2K020H	K3K020H	K4K020H K5K020H	-	-	
		ABS	K2K020T	K3K020T	K4K020T K5K020T	K7K515T	K11K015T K15K015T	
	1,000 r/min Servomotors	INC	-	K2K010H	K3K010H	-	-	
		ABS	-	K2K010T	K3K010T K4K510T	K6K010T	-	

*1. The heat value is given for rated operation.

● Servo Drives with 400 VAC Input Power for Three-phase input type

Item			R88D-KN06F-ECT	R88D-KN10F-ECT	R88D-KN15F-ECT	R88D-KN20F-ECT	R88D-KN30F-ECT	R88D-KN50F-ECT	R88D-KN75F-ECT	R88D-KN150F-ECT	
Continuous output current (rms)			1.5A	2.9A	4.7A	6.7A	9.4A	16.5A	22.0A	33.1A	
Input power supply	Main circuit	Power supply capacity	1.2KVA	1.8KVA	2.3KVA	3.8KVA	4.5KVA	6.0KVA	11.0KVA	22.0KVA	
		Power supply voltage	3-phase 380 to 480 VAC (323 to 528 V) 50/60 Hz								
		Rated current	2.1A	2.8A	4.7A	5.9A	7.6A	12.1A	16.0A	29.0A	
		Heat value*1	32.2W	48W	49W	65W	108W	200W	300W	590W	
	Control circuit	Power supply voltage	24 VDC (20.4 to 27.6 V)								
		Heat value*1	7W	7W	7W	10W	13W	13W	15W	22W	
Weight			Approx. 1.9kg	Approx. 1.9kg	Approx. 1.9kg	Approx. 2.7kg	Approx. 4.7kg	Approx. 4.7kg	Approx. 13.5kg	Approx. 21.0kg	
Maximum applicable motor capacity			600W	1kW	1.5kW	2kW	3kW	5kW	7.5kW	15kW	
Applicable Servomotor (R88M-)	3,000 r/min Servomotors	INC	-	K75030F	K1K030F K1K530F	K2K030F	K3K030F	K4K030F K5K030F	-	-	
		ABS	-	K75030C	K1K030C K1K530C	K2K030C	K3K030C	K4K030C K5K030C	-	-	
	2,000 r/min, 1,500 r/min Servomotors	INC	K40020F K60020F	K1K020F	K1K520F	K2K020F	K3K020F	K4K020F K5K020F	-	-	
		ABS	K40020C K60020C	K1K020C	K1K520C	K2K020C	K3K020C	K4K020C K5K020C	K7K515C	K11K015C K15K015C	
	1,000 r/min Servomotors	INC	-	-	K90010F	-	K2K010F	K3K010F	-	-	
			-	-	K90010C	-	K2K010C	K3K010C K4K510C	K6K010C	-	

*1. The heat value is given for rated operation.

EtherCAT Communications Specifications

Item	Specification
Communications standard	IEC 61158 Type 12, IEC 61800-7 CiA 402 Drive Profile
Physical layer	100BASE-TX (IEEE802.3)
Connectors	RJ45 × 2 (shielded) ECAT IN: EtherCAT input ECAT OUT: EtherCAT output
Communications media	Ethernet Category 5 (100BASE-TX) or higher (twisted-pair cable with double, aluminum tape and braided shielding) is recommended.
Communications distance	Distance between nodes: 100 m max.
Process data	Fixed PDO mapping
Mailbox (CoE)	Emergency messages, SDO requests, SDO responses, and SDO information
Distributed clock (DC)	Synchronization in DC mode. DC cycle: 250 μs, 500 μs, 1 ms, 2 ms, 4 ms
LED indicators	L/A IN (Link/Activity IN) × 1 L/A OUT (Link/Activity OUT) × 1 RUN × 1 ERR × 1
CiA402 Drive Profile	<ul style="list-style-type: none"> • Cyclic synchronous position mode • Cyclic synchronous velocity mode • Cyclic synchronous torque mode • Profile position mode • Homing mode • Touch probe function (Latch function) • Torque limit function

Version Information

Unit Versions

Unit	Model	Unit version		
		Unit version 1.0	Unit version 2.0	Unit version 2.1
AC Servo Drives G5-Series built-in EtherCAT Communications	R88D-KN□-ECT-R *1	Supported		
	R88D-KN□-ECT		Supported	Supported
Sysmac Studio version (At the time of the controller NJ series and connection)		Version 1.00 or higher *2	Version 1.00 or higher *3	Version 1.00 or higher
Sysmac Studio support version (At the time of the controller NX series and connection)		Ver. 1.13 or higher *2	Ver. 1.13 or higher *3	Ver. 1.13 or higher
Compatible CX-Drive version		Version 2.2 or higher	Version 2.3 or higher	Version 2.4 or higher

*1. Production was discontinued.

*2. The function that was enhanced by the upgrade for Unit version 2.0 can not be used. For detail, refer to "Function Support by Unit Version".

*3. The function that was enhanced by the upgrade for Unit version 2.1 can not be used. For detail, refer to "Function Support by Unit Version".

Function Support by Unit Version

Unit		AC Servo Drives G5-Series built-in EtherCAT Communications		
Model		R88D-KN□-ECT-R *1	R88D-KN□-ECT	
Unit version		Unit version 1.0	Unit version 2.0	Unit version 2.1
Sysmac Products Features	Sysmac Error Status	No supported		Supported
	Saving the Node Address Setting	No supported		Supported
	Serial Number Display *2	No supported		Supported
	ESI Specification (Version 1.0)	No supported		Supported
	SII Data Check	No supported		Supported
Fixed PDO mapping		No supported	Supported	
Variable PDO mapping (1600 hex, 1A00 hex)		No supported		Supported
Available operation modes	csp: Cyclic synchronous position mode	Supported		
	csv: Cyclic synchronous velocity mode	No supported	Supported	
	cst: Cyclic synchronous torque mode	No supported	Supported	
	pp: Profile position mode	No supported		Supported
	hm: Homing mode	No supported	Supported	
FIR filter function		No supported	Supported *3 (Available when the communications cycle is 1 ms or above)	
Error detection function	Excessive Speed Deviation Error	No supported	Supported	
	Interruptions Error	No supported	Supported	
Electronic gear function		Supported	No supported *4 (only to 1:1)	Supported

AC Servomotor/Drive G5-series

Unit Model	AC Servo Drives G5-Series built-in EtherCAT Communications		
	R88D-KN□-ECT-R *1	R88D-KN□-ECT	
Item	Unit version	Unit version 2.0	Unit version 2.1
Fully-closed Control *5	Supported	Available when the communications cycle is 500 μs or above in csp and 1 ms or above in hm.	Available when the communications cycle is 1 ms or above at an electronic gear ratio of 1:1 and 2 ms or above at a gear ratio other than 1:1. *6
Torque limit objects	PDO mapping to 60E0/60E1 hex is not possible.	PDO mapping to 60E0/60E1 hex is possible. *7	
Positioning Completion Range	No supported		Supported
Reference Position for CSP (4020 hex)	No supported		Supported
Data Setting Warning Detection Setting (3781)	No supported		Supported *8
Version indication on the unit label	No supported	Supported	

*1. Production was discontinued.

*2. The function to show the serial number controlled by OMRON in 1018h-04 hex.

*3. Setting the communications cycle to 500 μs or less does not enable the FIR filter function, although doing so does not cause any error.

*4. Setting this to an electronic gear ratio other than 1:1 simply causes the G5-series AC Servo Drive to operate at 1:1 without any errors.

*5. If Fully-closed Control is not available, a Function Setting Error (Error No. 93.4) will occur.

*6. This is applicable only when the total size of the objects mapped to RxPDO is 12 bytes or less. For details, refer to the USER'S MANUAL.

*7. There are objects added (3013 hex/3522 hex) to or renamed (3525 hex/3526 hex) from unit version 1.0.

For details of these objects, refer to Torque Limit Selection (3521 hex) in Extended Objects of each manual.

*8. Only the following Servo Drive models support DC power input:

- R88D-KN75H-ECT • R88D-KN150H-ECT

Components and Functions

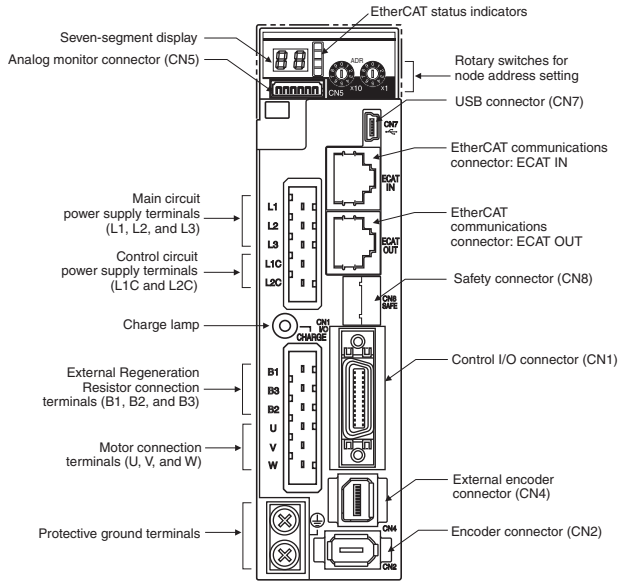

Display

A 2-digit 7-segment display shows the node address, error codes, and other Servo Drive status.

Charge Lamp

Lights when the main circuit power supply is turned ON.

EtherCAT Status Indicators

These indicators show the status of EtherCAT communications. For details, refer to the G5 series USER'S MANUAL (Cat.No.I576).

Control I/O Connector (CN1)

Used for command input signals and I/O signals.

Encoder Connector (CN2)

Connector for the encoder installed in the Servomotor.

External Encoder Connector (CN4)*

Connector for an encoder signal used during fully-closed control.

EtherCAT Communications Connectors (ECAT IN and ECAT OUT)

These connectors are for EtherCAT communications.

Analog Monitor Connector (CN5)

You can use a special cable to monitor values, such as the motor rotation speed, torque command value, etc.

USB Connector (CN7)

Communications connector for the computer.

Safety Connector (CN8)

Connector for safety devices.

If no safety devices are used, keep the factory-set safety bypass connector installed.

AC Servomotor/Drive G5-series

*External Encoder

Contact the encoder manufacturer to find out the detailed specifications such as operating environment before use.

External encoder type	Maker	Example of External encoder	Supported speed *1	Resolution *4 [μ m]	Maximum speed *4 [m/s]
90° phase difference output type *2 *3	–	Phase A/B type	0 to 4 Mpps (Multiplication \times 4)	–	–
Serial communications type (Incremental type) *3	Magnescale Co., Ltd	SL700+PL101RP/RHP SL710+PL101RP/RHP	0 to 400 Mpps	0.1	10
		SR75/SR85		0.01 to 1	3.3
		BF1		0.001/0.01	0.4/1.8
		SQ10+PQ11 SQ10+PQ10+MQ10		0.05/0.1/0.5/1	3
	NIDEC SANKYO CORPORATION	PSLH041+PSLG		0.1	6
Serial communications type (Absolute type) *3	HEIDENHAIN CORPORATION	LIC2197P/LIC2199P	0 to 400 Mpps	0.05/0.1	10
		LIC4193P/LIC4195P LIC4197P/LIC4199P		0.001/0.005/ 0.01	0.4/2/4
		LC195P/LC495P		0.001/0.01	3
	FAGOR AUTOMATION	SAP/SVAP/GAP		0.05	2.5
		S2AP/SV2AP/G2AP		0.01/0.05	3
		LAP		0.05/0.1	2
	Magnescale Co., Ltd	SR77/SR87		0.01 to 1	3.3
	Mitutoyo Corporation	AT573□		0.05	2.5
		ST77□□		0.1	5
		ST137□□		0.001/0.01	8
	Renishaw Co.	RESOLUTE		0.001	0.4
				0.05	20
				0.1	40

*1. The supported speed is the internal feedback pulse speed [external encoder pulse/s] of the external encoder that can be processed by the Servo Drive.

Check the instruction manual of the external encoder for the speed range supported by your external encoder.

*2. These are the directions that the Drive counts a 90° phase difference output.

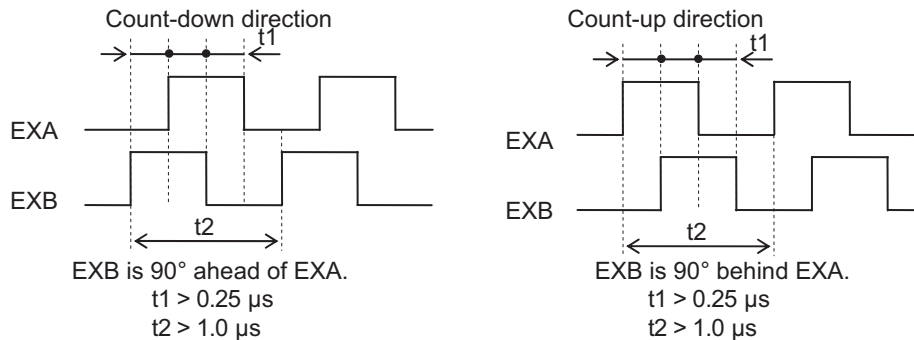

*3. For the external encoder connection direction, set the direction so that count-up occurs when the motor shaft is rotating counterclockwise, and count-down occurs when the motor shaft is rotating clockwise. If the connection direction cannot be selected due to installation conditions or any other reason, the count direction can be reversed using External Feedback Pulse Direction Switching (3326 hex).

*4. The resolution and maximum speed are the values for the G5-series Servo Drive. The resolution and maximum speed may be different from the specifications of the feedback encoder due to restriction on the maximum pulse frequency of the Servo Drive.

Dimensions

<Wall Mounting>

Single-phase 100 VAC R88D-KNA5L-ECT/-KN01L-ECT (50 to 100 W)
R88D-KN01L-ECT-L (100 W)

Single-phase/Three-phase 200 VAC R88D-KN01H-ECT/-KN02H-ECT (100 to 200 W)
R88D-KN01H-ECT-L/-KN02H-ECT-L (100 to 200 W)

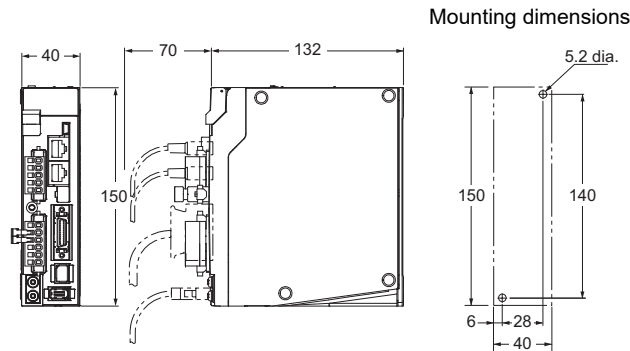

Single-phase 100 VAC R88D-KN02L-ECT (200 W)
R88D-KN02L-ECT-L (200 W)

Single-phase/Three-phase 200 VAC R88D-KN04H-ECT (400 W)
R88D-KN04H-ECT-L (400 W)

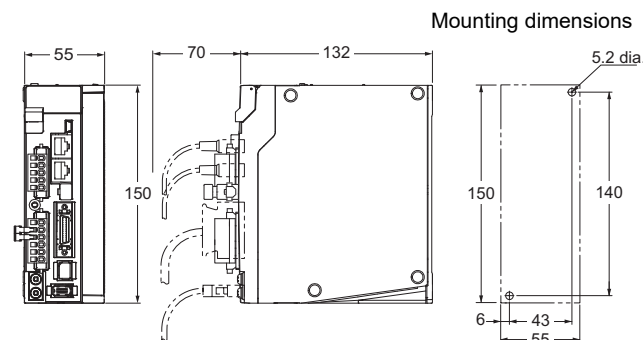

Single-phase 100 VAC R88D-KN04L-ECT (400 W)
R88D-KN04L-ECT-L (400 W)

Single-phase/Three-phase 200 VAC R88D-KN08H-ECT (750 W)
R88D-KN08H-ECT-L (750 W)

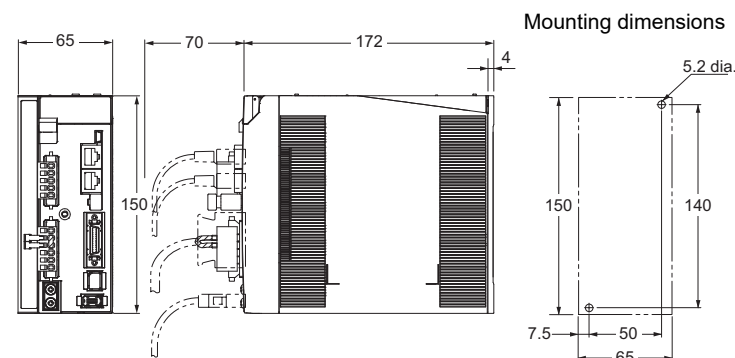

Note: R88D-KN□-ECT-L is the AC Servo Drives with Built-in EtherCAT Communications type.

Single-phase/Three-phase 200 VAC R88D-KN10H-ECT/-KN15H-ECT (900 W to 1.5 kW)
R88D-KN10H-ECT-L/-KN15H-ECT-L (1 kW to 1.5 kW)

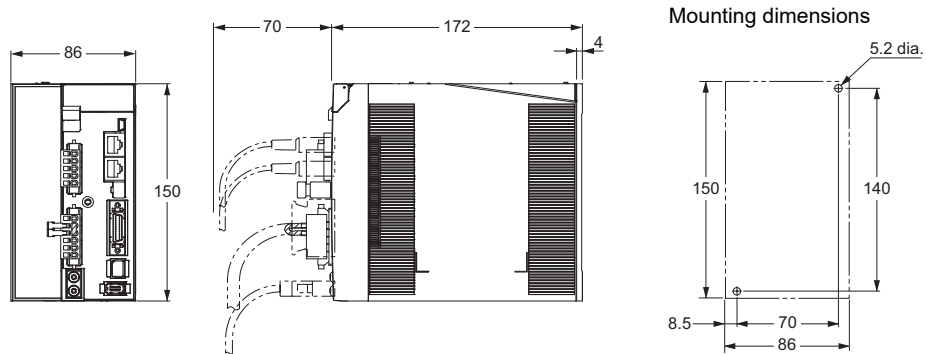

Three-phase 200 VAC R88D-KN20H-ECT (2 kW)

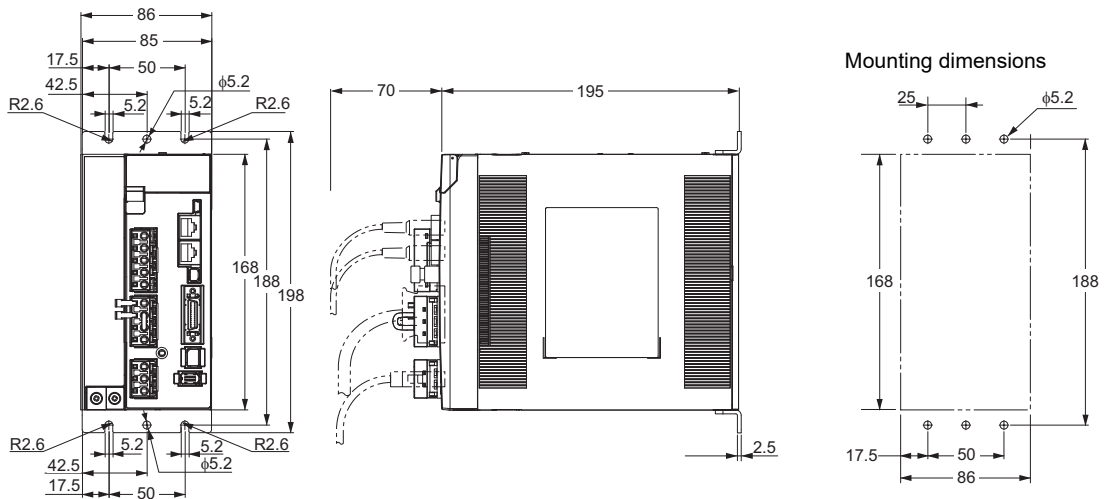

Three-phase 200 VAC R88D-KN30H-ECT/-KN50H-ECT (3 to 5 kW)

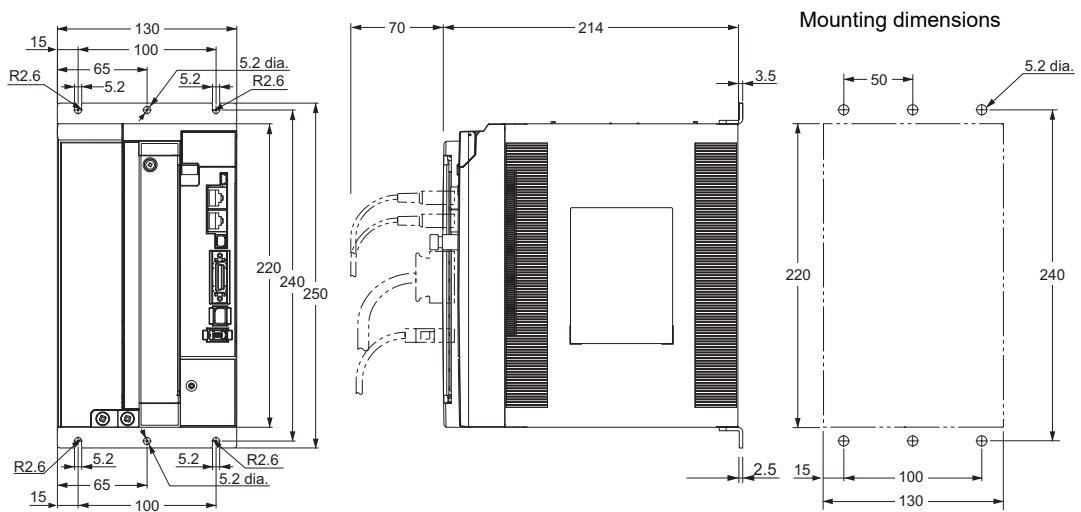

Three-phase 200 VAC R88D-KN75H-ECT (7.5 kW)

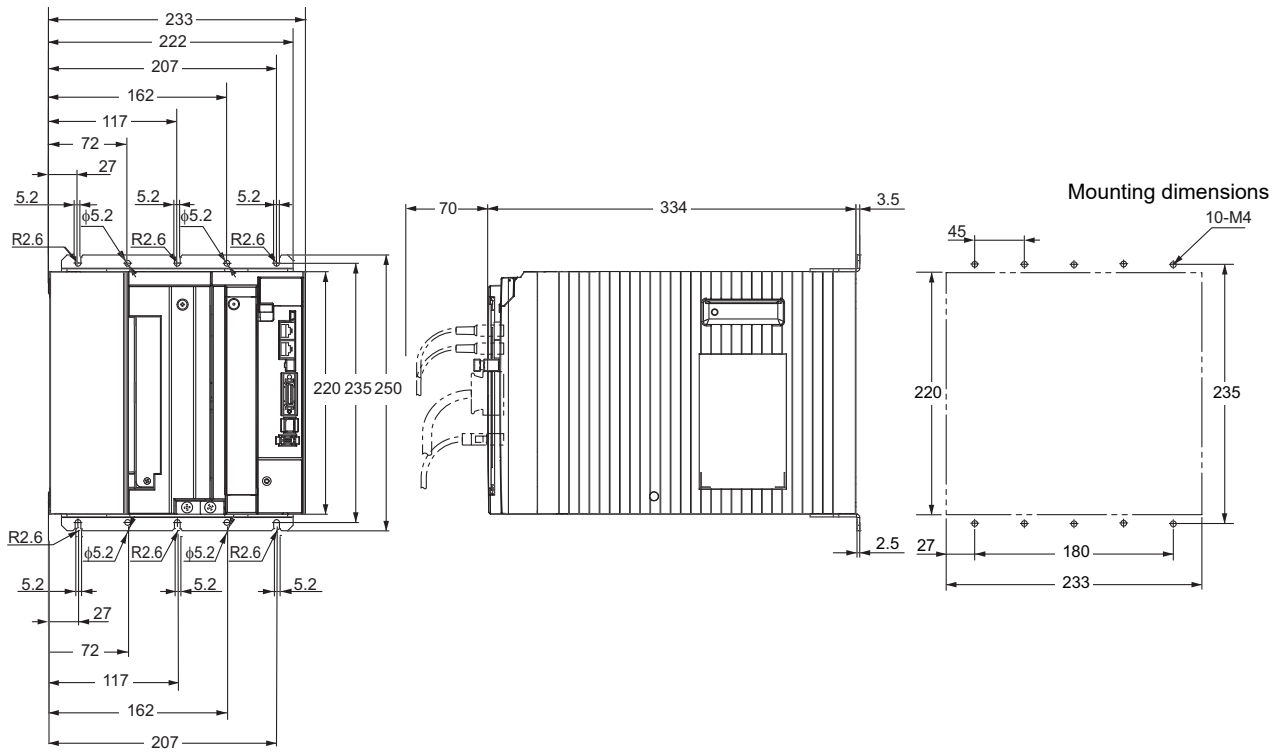

Three-phase 200 VAC R88D-KN150H-ECT (15 kW)

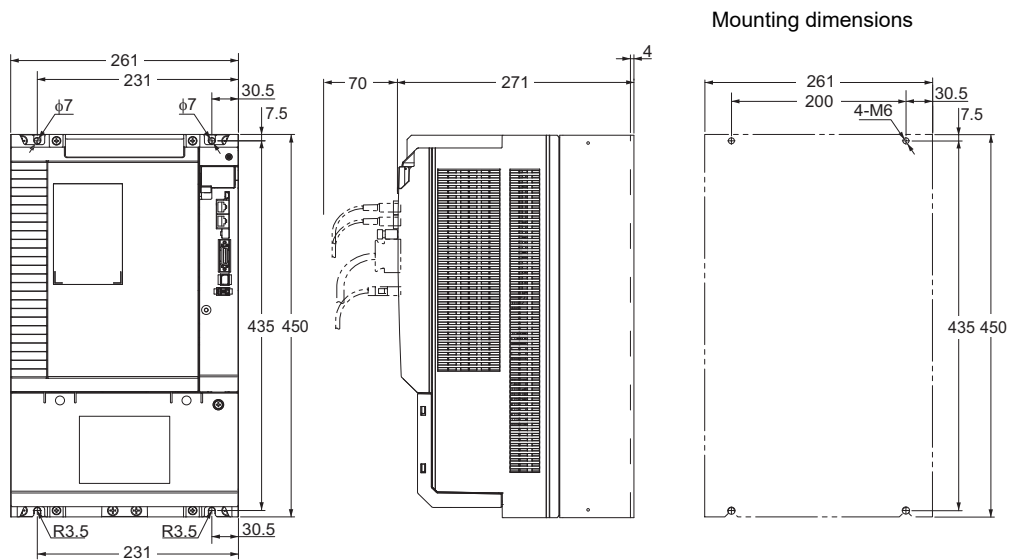

G5-Series
System Configuration

EtherCAT Communications
AC Servo Drive

EtherCAT Communications
Linear Motor Type
AC Servo Drive

General-purpose Inputs
AC Servo Drive

ML-II Type
AC Servo Drive

AC Servomotors

Linear Motor

Decelerator

Three-phase 400 VAC R88D-KN06F-ECT/-KN10F-ECT (600 W to 1.0 kW)
R88D-KN06F-ECT-L/-KN10F-ECT-L (600 W to 1.0 kW)
Three-phase 400 VAC R88D-KN15F-ECT (1.5 kW)
R88D-KN15F-ECT-L (1.5 kW)

Mounting dimensions

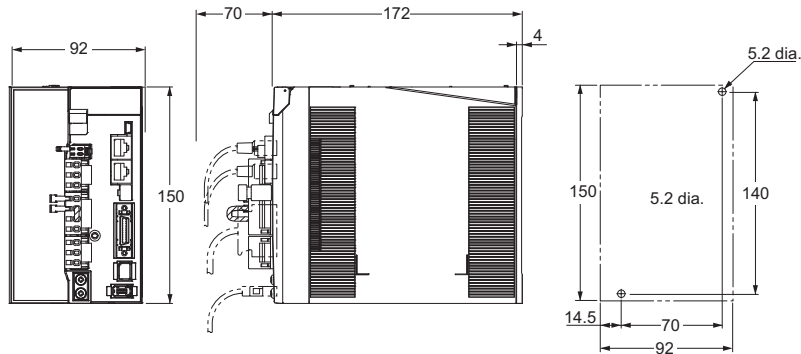

Three-phase 400 VAC R88D-KN20F-ECT (2 kW)
R88D-KN20F-ECT-L (2 kW)

Mounting dimensions

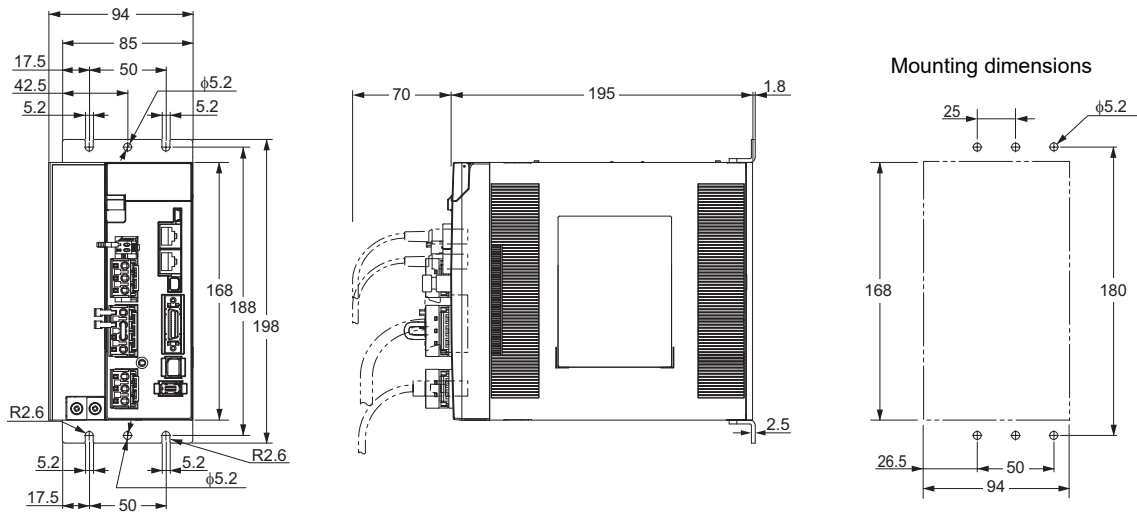

Three-phase 400 VAC R88D-KN30F-ECT/-KN50F-ECT (3 to 5 kW)
R88D-KN30F-ECT-L (3 kW)

Mounting dimensions

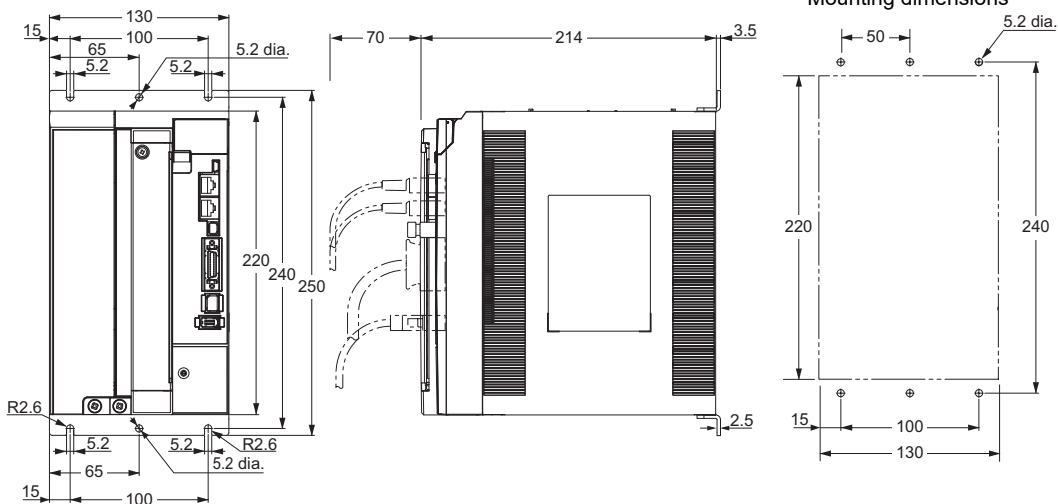

Three-phase 200 VAC R88D-KN75H-ECT (7.5 kW)

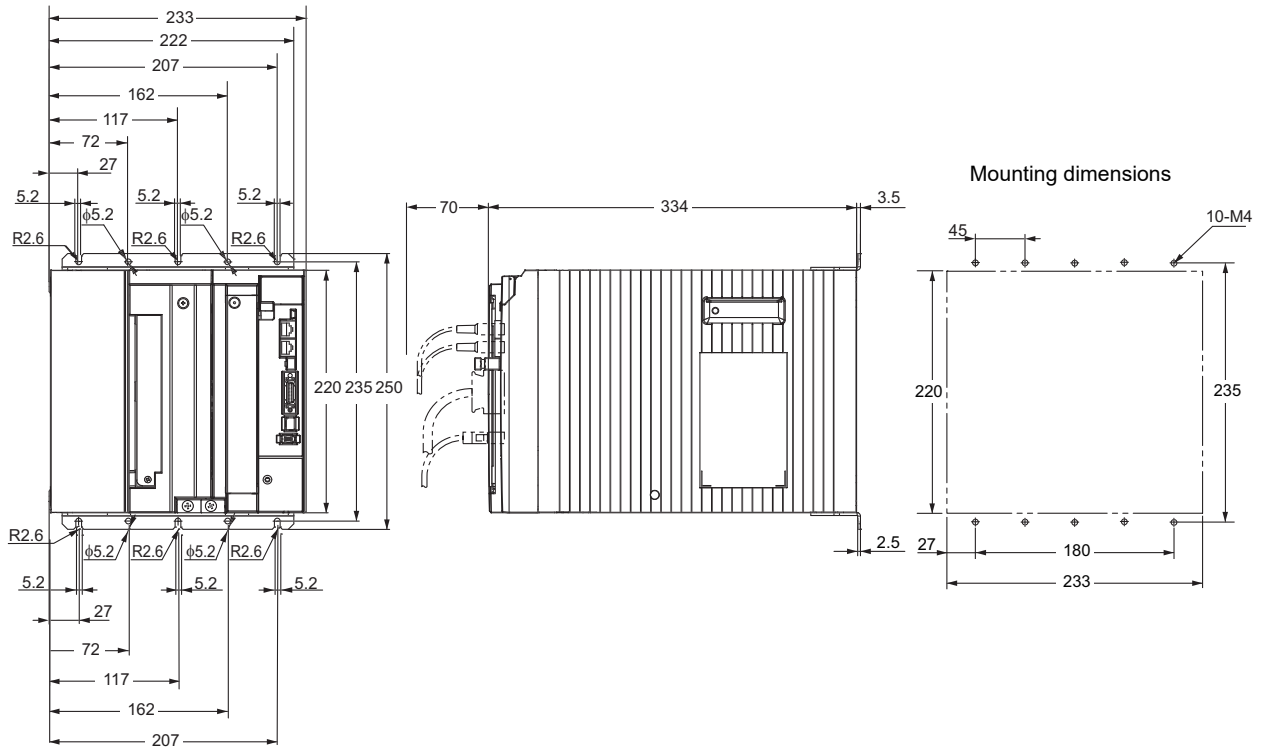

Three-phase 400 VAC R88D-KN150F-ECT (15kW)

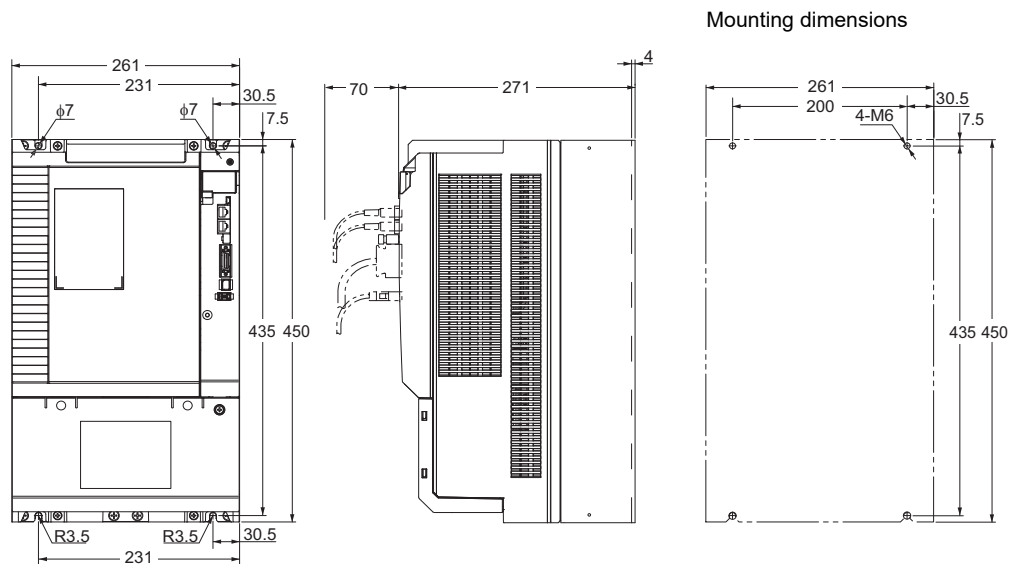

G5-Series
System Configuration

EtherCAT Communications
AC Servo Drive

EtherCAT Communications
Linear Motor Type
AC Servo Drive

General-purpose Inputs
AC Servo Drive

ML-II Type
AC Servo Drive

AC Servomotors

Linear Motor

Decelerator