



■ Some of the photos may include optional equipment.

HYUNDAI MATERIAL HANDLING **Applied Tier 4 Engine**

25/30/33L-7A



NEW criteria of Forklift Trucks

Hyundai introduces a new line of 7A series
LPG forklift trucks.
Excellent power and performance make your
business more profitable.



OPSS (Operator Presence Sensing System)

Control of mast tilting, lifting and lowering is not possible through operation of the appropriate control when the operator is not in the seated position. **Option**



■ Some of the photos may include optional equipment.

The new master on the job-site!

Smooth running, efficient and ergonomically designed, 25/30/33L-7A are made to meet your needs.

44kW/2,300rpm

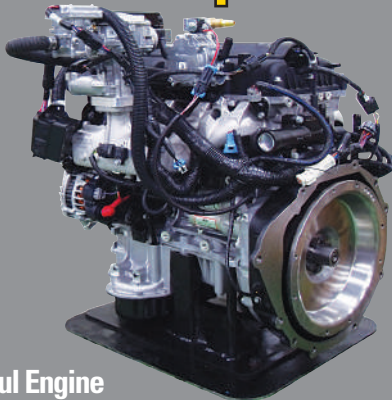

Powerful Engine HMC L4KB(2.4L) Engine

Market approved quality of HMC L4KB engine ensures incomparable performance, durability and additional value to the machine. Powerful and efficient engine provides excellent fuel consumption and excellent torque improved operator's comfort.

(EPA/CARB Tier-IV Certified)

Fast and Stable Performance

Being able to quickly raise and lower the mast, as well as tilt it forward and backward, provides the best operational conditions during unloading.

When the truck is fully loaded, mast lowering speed is carefully controlled to ensure safety by the down control valve.

Mast(Lift and Tilt) Look System. **Option**

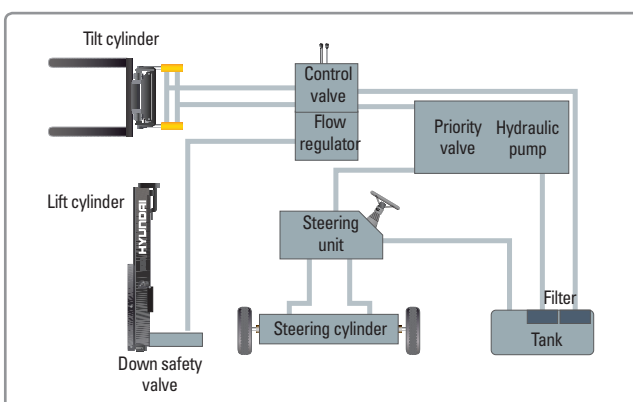

State-of-the-art Hydraulic System

The latest large-capacity hydraulic system reacts quickly during operation, and a low-noise control valve increases both efficiency and durability.



Fully Hydrostatic Power Steering

A hydraulic steering system always guarantees smooth and flexible steering, preventing overrun and kick-back.



**High Power
Low Noise**

■ Some of the photos may include optional equipment.

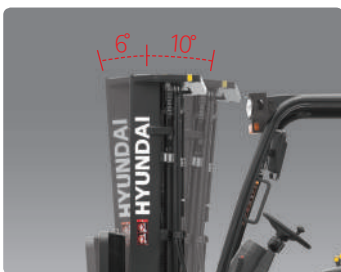

Increased Mast Tilting Angle

Utilizing the mast tilting angle of 6 degrees forward and 10 degrees backward, the operator can safely and rapidly perform loading and unloading jobs.

Faster Travel Speed & Better Gradability

The powerful high-output engine provides greater acceleration, better gradability and faster travel speed on any tough terrains or slopes.



Gradability(Loaded)

25L-7A : 20.4°

30L-7A : 16.6°

33L-7A : 15.4°

Travel Speed(Unloaded)

25L-7A : 17.7 km/h

30L-7A : 18.6 km/h

33L-7A : 18.6 km/h

Ergonomic operator friendly compartment design!

A design based on human engineering relieves fatigue and increases operator's efficiency.

Operator Friendly Gauges and Water-resistant Monitor Panel

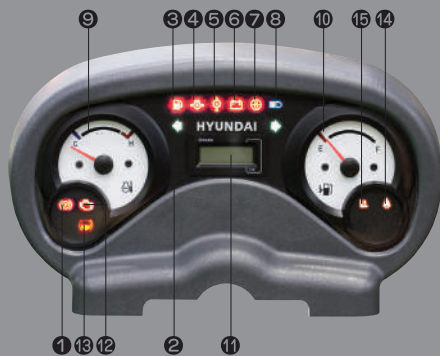

- | | | |
|---|------------------------------------|--------------------------|
| ① Parking brake lamp | ⑥ Battery charging warning lamp | ⑫ Engine check lamp |
| ② Directional indicators | ⑦ Air cleaner filter warning light | ⑬ Brake oil warning lamp |
| ③ Fuel warning lamp | ⑧ Working light indicator | ⑭ Seat belt warning |
| ④ Engine oil warning lamp | ⑨ Water temperature gauge | ⑮ OPS warning |
| ⑤ Transmission oil temperature warning lamp | ⑩ Fuel gauge | |
| | ⑪ Hour meter | |



New High Visibility for Safe Operation

The operator is able to work with increased safety and accuracy due to a wider view mast.

Full suspension seat



An attractive and adjustable seat, based on a human engineering design, provides great comfort, safety and durability.

Grammer Seat Option



- Quick Achievement of the Ergonomically Best Sitting Position
- Asymmetrical Backrest
- Movable Armrests
- Seat Heating
- Practical Document Box



Ergonomically Positioned Pedals

Based on human engineering, the accelerator, brake and inching pedals are optimally positioned for convenience while operating the equipment.



Cup Holder & Console Box

Additional storage spaces are located inside the operating space for operator's convenience.



Quick Response of Operating Control Levers

Only minimal operator's effort is required for precise, safe and productive control.



Travel Speed Control System Option



← In-Door : Max. Travel Speed (5 ~ 16 km/h)

← Out-Door : Max Travel Speed (Max Vehicle Speed)

■ Some of the photos may include optional equipment.



Adjustable Steering Wheel

Steering wheel with horn button can be adjusted by a lever on the right-hand side for the most comfortable operator position.



Easy and Safe Shift Lever

A single lever on the left side of the steering column gives the operator fast, easy control of direction. The lever must be in the neutral position before the engine can be started.



Secondary Horn

Secondary Horn gives access to lights and horn

Danger-free through high durability!

Safety and durability are priorities in design of the equipment.



Strong Overhead Guard

The safety overhead guard meets ISO 6055 regulation and protects the operator during hazardous jobs.

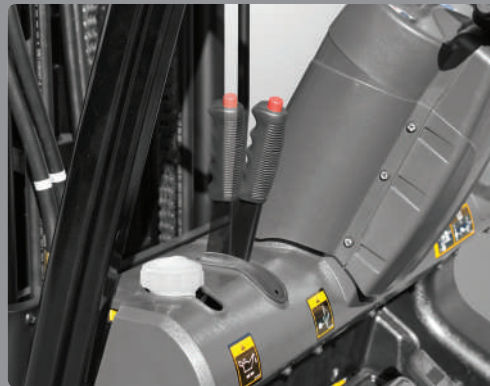

Parking Brake

Ratchet type parking brake requires less effort from the operator to set.

Highly Durable Split Type Drive Axle

The bevel gear set and hub reduction axle smoothly delivers desired torque to the drive wheels.

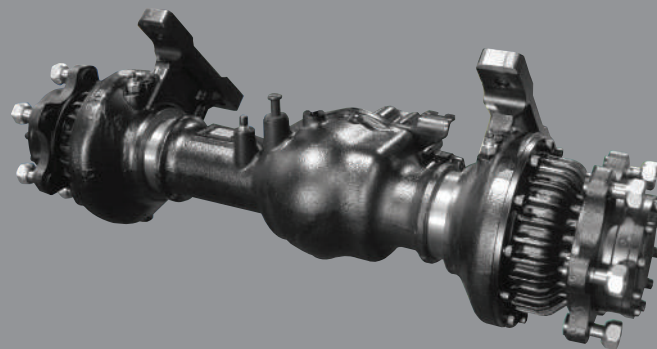

Large Footboard & Hand Grip

Wide "open" step offers convenience and safety when entering and exiting truck.



Expansion Bellows

The expansion bellows absorbs vibration and reduces noise generated from the exhaust gas system and also extends the life cycle of exhaust gas system.



Electrically Monitored Air Filter

Air cleaner sensor alerts the operator of a restricted air filter and allows replacement before damage.

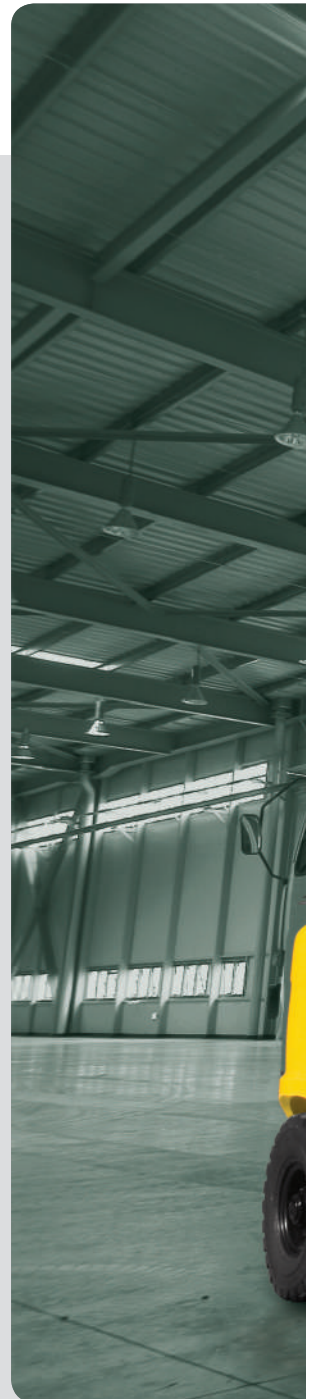



■ Some of the photos may include optional equipment.

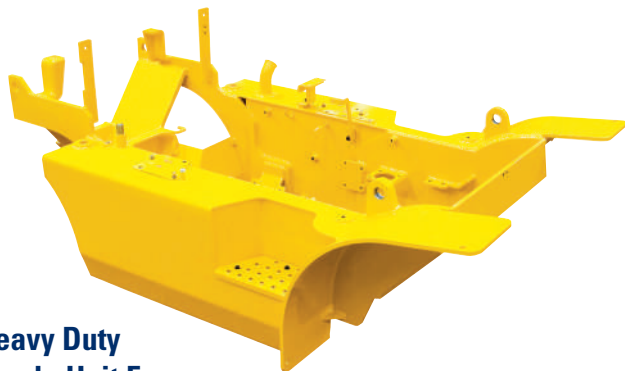

Heavy Duty Single Unit Frame

Heavy duty single unit type frame, designed on the basis of accurate structural analysis, guarantees durability and safety.



Bright, Protected Headlights

Bright, Protected head lights are positioned for exceptional visibility.

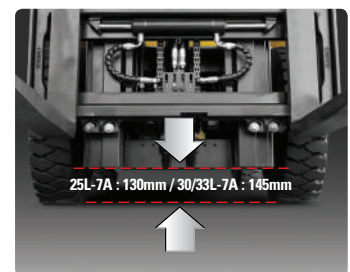

Ground Clearance

The engine and transmission are assembled horizontally and positioned high in the frame to protect major components during operation on rugged surface.

Designed for quick and easy service!

An ideal arrangement of component parts ensures easy access and convenience for maintenance.



Easy Change Air Cleaner

The air filter is readily accessible for cleaning or replacement. (6inch Cyclone Type)



Fast Service Access for Daily Fluids Check



Rotational Battery Installation



One Touch, No Tool Floor Plate



Removable Side Panels for Ease of Service



Improvement in Maintenance of Electric Parts

Various electric parts are centralized in dash board resulting in effortless troubleshooting.

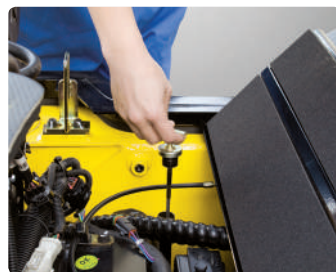

Easy Maintenance Oil Check

The T/M oil level can be checked easily without any disassembly.



Brake Fluid Reservoir with Level Switch

When brake oil level become lower than Min. the warning lamp on the cluster lights on.



An Accessible, Compact Fuse Box for Easy Inspection

Mast Specification - 25L-7A

Mast Type	Maximum Fork Height		Overall Height Lowered				FREE LIFT						Tilt Angle		Load capacity w/o integral side shift				Load capacity w/integral side shift				TRUCK WEIGHT UNLOAD			
							SINGLE		SINGLE		Fwd	Bwd	Single Tire		Double Tire		Single Tire		Double Tire		Single Tire		Double Tire			
	with bkr		w/o bkr		w/o bkr (3/4-SPOOL)		24 in LC	500mm LC	24 in LC	500mm LC			24 in LC	500mm LC	24 in LC	500mm LC	lb	kg	lb	kg						
	in	mm	in	mm	in	mm	in	mm	in	mm	deg	deg	lb	kg	lb	kg	lb	kg	lb	kg	lb	kg	lb	kg		
2-STAGE LIMITED FREE LIFT	V300	118.1	3,000	79.7	2,025	6.1	155	6.1	155	6.1	155	6	10	5,000	2,500	5,000	2,500	5,000	2,410	5,000	2,430	8,127	3,687	8,560	3,883	
	*V330	129.9	3,300	85.6	2,175	6.1	155	6.1	155	6.1	155	6	10	5,000	2,500	5,000	2,500	5,000	2,380	5,000	2,400	8,171	3,706	8,603	3,902	
	V350	137.8	3,500	89.6	2,275	6.1	155	6.1	155	6.1	155	6	10	5,000	2,500	5,000	2,500	5,000	2,350	5,000	2,370	8,208	3,723	8,641	3,919	
	V370	145.7	3,700	95.5	2,425	6.1	155	6.1	155	6.1	155	6	10	5,000	2,500	5,000	2,500	4,820	2,320	5,000	2,340	8,257	3,745	8,689	3,941	
	V400	157.4	4,000	101.4	2,575	6.1	155	6.1	155	6.1	155	6	10	4,930	2,450	5,000	2,500	4,750	2,270	4,820	2,310	8,323	3,775	8,755	3,971	
V450	177.2	4,500	113.2	2,875	6.1	155	6.1	155	6.1	155	6	6	4,740	2,350	4,938	2,420	4,560	2,180	4,758	2,230	8,485	3,849	8,918	4,045		
2-STAGE FULL	VF325	127.9	3,250	85.6	2,175	39.2	995	60.1	1,527	54.0	1,371	6	6	5,000	2,500	5,000	2,500	5,000	2,350	5,000	2,500	8,302	3,766	8,737	3,963	
3-STAGE FULL FREE LIFT	TF430	169.3	4,300	79.7	2,025	33.3	845	54.2	1,377	53.0	1,346	6	6	4,710	2,350	4,850	2,420	4,530	2,180	4,670	2,230	8,521	3,865	8,955	4,062	
	TF450	177.2	4,500	83.7	2,125	37.2	945	58.1	1,477	58.1	1,477	6	6	4,540	2,300	4,760	2,370	4,360	2,130	4,580	2,180	8,569	3,887	9,004	4,084	
	TF470	185.0	4,700	85.6	2,175	39.2	995	60.1	1,527	58.9	1,496	6	6	4,400	2,250	4,670	2,350	4,220	2,080	4,490	2,160	8,599	3,900	9,033	4,097	
	TF500	196.9	5,000	89.6	2,275	43.1	1,095	64.1	1,627	62.8	1,596	6	6	3,520	2,200	4,580	2,270	3,340	2,040	4,400	2,090	8,648	3,923	9,082	4,120	
	TF550	216.5	5,500	97.4	2,475	51.0	1,295	71.9	1,827	71.9	1,827	6	6	2,640	1,550	4,400	2,200	2,460	1,420	4,220	2,020	8,734	3,962	9,168	4,159	
	TF600	236.2	6,000	105.3	2,675	58.9	1,495	79.8	2,027	79.8	2,027	6	6	1,760	1,400	3,520	2,100	1,580	1,280	3,340	1,930	8,877	4,027	9,311	4,224	
	TS430	169.3	4,300	79.7	2,025	33.3	845	54.2	1,377	49.3	1,253	6	6	4,710	2,350	4,850	2,420	4,530	2,180	4,670	2,230	8,521	3,865	8,955	4,062	
	TS450	177.2	4,500	83.7	2,125	37.2	945	58.1	1,477	55.2	1,403	6	6	4,540	2,300	4,760	2,370	4,360	2,130	4,580	2,180	8,569	3,887	9,004	4,084	
	TS470	185.0	4,700	85.6	2,175	39.2	995	60.1	1,527	55.2	1,403	6	6	4,400	2,250	4,670	2,350	4,220	2,080	4,490	2,160	8,599	3,900	9,033	4,097	
	TS500	196.9	5,000	89.6	2,275	43.1	1,095	64.1	1,627	59.2	1,503	6	6	3,520	2,200	4,580	2,270	3,340	2,040	4,400	2,090	8,648	3,923	9,082	4,120	
	TS550	216.5	5,500	97.4	2,475	51.0	1,295	71.9	1,827	69.0	1,753	6	6	2,640	1,550	4,400	2,200	2,460	1,420	4,220	2,020	8,734	3,962	9,168	4,159	
TS600	236.2	6,000	105.3	2,675	58.9	1,495	79.8	2,027	76.9	1,953	6	6	1,760	1,400	3,520	2,100	1,580	1,280	3,340	1,930	8,877	4,027	9,311	4,224		
4-STAGE FULL FREE LIFT	QF610	240.7	6,115	85.0	2,160	39.3	997	59.5	1,512	57.6	1,462	3	3	3,310	1,600	3,810	1,850	3,170	1,470	3,520	1,700	9,341	4,237	9,773	4,433	
	QF700	276.2	7,015	96.8	2,460	51.1	1,297	71.3	1,812	69.4	1,762	3	3	2,910	1,400	3,510	1,700	2,780	1,280	3,310	1,550	9,539	4,327	9,971	4,523	

* TS-Mast : Wide Visible 3 Stage Full Free Lift Mast with 2 Free Lift Cylinders.

Mast Specification - 30L-7A

Mast Type	Maximum Fork Height		Overall Height Lowered		FREE LIFT						Tilt Angle		Load capacity w/o integral side shift				Load capacity w/integral side shift				TRUCK WEIGHT UNLOAD							
					with bkr		w/o bkr		w/o bkr (3/4-SPOOL)		Fwd	Bwd	Single Tire		Double Tire		Single Tire		Double Tire		Single Tire		Double Tire					
	in	mm	in	mm	in	mm	in	mm	in	mm	deg	deg	24 in LC	500mm LC	24 in LC	500mm LC	24 in LC	500mm LC	24 in LC	500mm LC	lb	kg	lb	kg	lb	kg	lb	kg
2-STAGE LIMITED FREE LIFT	V300	118.1	3,000	80.3	2,040	6.1	155	6.1	155	6.1	155	6	10	6,000	3,000	6,000	3,000	6,000	2,890	6,000	2,900	9,205	4,175	9,555	4,334			
	*V330	129.9	3,300	86.2	2,190	6.1	155	6.1	155	6.1	155	6	10	6,000	3,000	6,000	3,000	6,000	2,860	6,000	2,870	9,250	4,196	9,599	4,354			
	V350	137.8	3,500	90.2	2,290	6.1	155	6.1	155	6.1	155	6	10	6,000	3,000	6,000	3,000	6,000	2,830	6,000	2,840	9,289	4,213	9,638	4,372			
	V370	145.7	3,700	96.1	2,440	6.1	155	6.1	155	6.1	155	6	10	6,000	3,000	6,000	3,000	6,000	2,800	6,000	2,810	9,339	4,236	9,689	4,395			
	V400	157.4	4,000	102.0	2,590	6.1	155	6.1	155	6.1	155	6	10	6,000	3,000	6,000	3,000	5,920	2,770	6,000	2,780	9,407	4,267	9,757	4,426			
V450	177.2	4,500	113.8	2,890	6.1	155	6.1	155	6.1	155	6	6	5,730	2,870	1,900	2,950	5,550	2,650	1,720	2,710	9,573	4,342	9,923	4,501				
2-STAGE FULL	VF325	127.9	3,250	86.2	2,190	39.8	1,010	57.6	1,464	57.6	1,464	6	6	6,000	3,000	6,000	3,000	6,000	2,850	6,000	3,000	9,371	4,251	9,720	4,409			
3-STAGE FULL FREE LIFT	TF430	169.3	4,300	80.3	2,040	33.9	860	51.7	1,314	46.3	1,175	6	6	5,730	2,850	5,880	2,920	5,670	2,630	5,780	2,680	9,638	4,372	9,986	4,530			
	TF450	177.2	4,500	84.3	2,140	37.8	960	55.7	1,414	52.2	1,325	6	6	5,660	2,800	5,760	2,870	5,560	2,580	5,670	2,630	9,694	4,397	10,042	4,555			
	TF470	185.0	4,700	86.2	2,190	39.8	1,010	57.6	1,464	52.2	1,325	6	6	5,400	2,770	5,660	2,820	5,220	2,550	5,480	2,580	9,725	4,411	10,073	4,569			
	TF500	196.9	5,000	90.2	2,290	43.7	1,110	61.6	1,564	56.1	1,425	6	6	4,630	2,700	5,510	2,770	4,450	2,490	5,330	2,540	9,774	4,434	10,123	4,592			
	TF550	216.5	5,500	98.0	2,490	51.6	1,310	69.4	1,764	65.9	1,675	6	6	3,040	1,750	5,290	2,670	2,860	1,590	5,110	2,440	9,871	4,478	10,220	4,636			
	TF600	236.2	6,000	105.9	2,690	59.4	1,510	77.3	1,964	73.8	1,875	6	6	2,020	1,450	4,630	2,570	1,840	1,310	4,450	2,350	10,026	4,548	10,374	4,706			
	TS430	169.3	4,300	80.3	2,040	33.9	860	51.7	1,314	49.3	1,253	6	6	5,730	2,850	5,880	2,920	5,670	2,630	5,780	2,680	9,638	4,372	9,986	4,530			
	TS450	177.2	4,500	84.3	2,140	37.8	960	55.7	1,414	55.2	1,403	6	6	5,660	2,800	5,760	2,870	5,560	2,580	5,670	2,630	9,694	4,397	10,042	4,555			
	TS470	185.0	4,700	86.2	2,190	39.8	1,010	57.6	1,464	55.2	1,403	6	6	5,400	2,770	5,660	2,820	5,220	2,550	5,480	2,580	9,725	4,411	10,073	4,569			
	TS500	196.9	5,000	90.2	2,290	43.7	1,110	61.6	1,564	59.2	1,503	6	6	4,630	2,700	5,510	2,770	4,450	2,490	5,330	2,540	9,774	4,434	10,123	4,592			
TS550	216.5	5,500	98.0	2,490	51.6	1,310	69.4	1,764	69.0	1,753	6	6	3,040	1,750	5,290	2,670	2,860	1,590	5,110	2,440	9,871	4,478	10,220	4,636				
TS600	236.2	6,000	105.9	2,690	59.4	1,510	77.3	1,964	76.9	1,953	6	6	2,020	1,450	4,630	2,570	1,840	1,310	4,450	2,350	10,026	4,548	10,374	4,706				
4-STAGE FULL FREE LIFT	QF610	240.7	6,115	85.6	2,175	37.6	955	57.0	1,449	57.0	1,449	3	3	3,730	1,800	4,850	2,350	3,550	1,640	4,590	2,150	10,351	4,695	10,701	4,854			
	QF700	276.2	7,015	97.4	2,475	51.0	1,295	68.9	1,749	68.9	1,749	3	3	3,110	1,500	4,430	2,150	2,950	1,360	4,190	1,960	10,549	4,785	10,899	4,944			

* TS-Mast : Wide Visible 3 Stage Full Free Lift Mast with 2 Free Lift Cylinders.

Mast Specification - 33L-7A

Mast Type		Maximum Fork Height		Overall Height Lowered		FREE LIFT						Tilt Angle		Load capacity w/o integral side shift				Load capacity w/integral side shift				TRUCK WEIGHT UNLOAD					
						with bkr		w/o bkr		w/o bkr (3/4-SPOOL)		Fwd	Bwd	Single Tire		Double Tire		Single Tire		Double Tire		Single Tire		Double Tire			
		in	mm	in	mm	mm	in	mm	in	mm	in	deg	deg	24 in LC	500mm LC	24 in LC	500mm LC	24 in LC	500mm LC	24 in LC	500mm LC	lb	kg	lb	kg	lb	kg
2-STAGE LIMITED FREE LIFT	V300	118.1	3,000	83.1	2,110	155	6.1	155	6.1	155	6.1	6	10	6,500	3,300	6,500	3,300	6,500	3,170	6,500	3,240	9,733	4,415	9,947	4,512		
	*V330	129.9	3,300	89.0	2,260	155	6.1	155	6.1	155	6.1	6	10	6,500	3,300	6,500	3,300	6,500	3,140	6,500	3,210	9,785	4,439	9,999	4,536		
	V350	137.8	3,500	92.9	2,360	155	6.1	155	6.1	155	6.1	6	10	6,500	3,300	6,500	3,300	6,500	3,110	6,500	3,180	9,820	4,454	10,034	4,551		
	V370	145.7	3,700	98.8	2,510	155	6.1	155	6.1	155	6.1	6	10	6,500	3,300	6,500	3,300	6,500	3,080	6,500	3,150	9,872	4,478	10,086	4,575		
	V400	157.4	4,000	104.7	2,660	155	6.1	155	6.1	155	6.1	6	10	6,500	3,300	6,500	3,300	6,500	3,050	6,500	3,120	9,943	4,510	10,157	4,607		
V450	177.2	4,500	116.5	2,960	155	6.1	155	6.1	155	6.1	6	6	6,500	3,150	6,500	3,300	6,500	2,910	6,500	3,060	10,113	4,587	10,327	4,684			
2-STAGE FULL	VF325	127.9	3,250	89.0	2,260	1,080	42.5	1,534	60.4	1,534	60.4	6	6	6,500	3,300	6,500	3,300	6,500	3,150	6,500	3,300	9,908	4,494	10,109	4,585		
3-STAGE FULL FREE LIFT	TF430	169.3	4,300	82.3	2,090	910	35.8	1,269	50.0	1,269	50.0	6	6	6,500	3,100	6,500	3,300	6,500	2,860	6,500	3,030	10,239	4,644	10,440	4,735		
	TF450	177.2	4,500	86.2	2,190	1,010	39.8	1,369	53.9	1,369	53.9	6	6	6,500	3,030	6,500	3,250	6,430	2,800	6,500	2,990	10,287	4,666	10,488	4,757		
	TF470	185.0	4,700	88.2	2,240	1,060	41.7	1,419	55.9	1,419	55.9	6	6	6,500	3,000	6,500	3,200	6,390	2,770	6,500	2,940	10,317	4,680	10,517	4,771		
	TF500	196.9	5,000	92.1	2,340	1,160	45.7	1,519	59.8	1,519	59.8	6	6	6,480	2,940	6,500	3,120	6,260	2,710	6,500	2,870	10,366	4,702	10,567	4,793		
	TF550	216.5	5,500	100	2,540	1,360	53.5	1,719	67.7	1,719	67.7	6	6	4,400	2,200	6,500	3,000	4,190	2,020	6,390	2,750	10,463	4,746	10,664	4,837		
	TF600	236.2	6,000	107.9	2,740	1,560	61.4	1,919	75.6	1,919	75.6	6	6	2,420	1,500	6,390	2,900	2,200	1,360	6,170	2,660	10,623	4,818	10,823	4,909		
	TS430	169.3	4,300	82.3	2,090	910	35.8	1,269	50.0	1,269	50.0	6	6	6,500	3,100	6,500	3,300	6,500	2,860	6,500	3,030	10,239	4,644	10,440	4,735		
	TS450	177.2	4,500	86.2	2,190	1,010	39.8	1,369	53.9	1,369	53.9	6	6	6,500	3,030	6,500	3,250	6,430	2,800	6,500	2,990	10,287	4,666	10,488	4,757		
	TS470	185.0	4,700	88.2	2,240	1,060	41.7	1,419	55.9	1,419	55.9	6	6	6,500	3,000	6,500	3,200	6,390	2,770	6,500	2,940	10,317	4,680	10,517	4,771		
	TS500	196.9	5,000	92.1	2,340	1,160	45.7	1,519	59.8	1,519	59.8	6	6	6,480	2,940	6,500	3,120	6,260	2,710	6,500	2,870	10,366	4,702	10,567	4,793		
TS550	216.5	5,500	100	2,540	1,360	53.5	1,719	67.7	1,719	67.7	6	6	4,400	2,200	6,500	3,000	4,190	2,020	6,390	2,750	10,463	4,746	10,664	4,837			
TS600	236.2	6,000	107.9	2,740	1,560	61.4	1,919	75.6	1,919	75.6	6	6	2,420	1,500	6,390	2,900	2,200	1,360	6,170	2,660	10,623	4,818	10,823	4,909			
4-STAGE FULL FREE LIFT	QF610	240.7	6,115	87.6	2,225	1,045	41.1	1,449	57.0	1,449	57.0	3	3	4,300	1,950	6,240	2,830	4,080	1,790	6,060	2,600	10,786	4,893	10,955	4,969		
	QF700	276.2	7,015	99.4	2,525	1,345	53.0	1,749	68.9	1,749	68.9	3	3	3,300	1,500	5,690	2,580	3,080	1,360	5,420	2,360	10,985	4,983	11,153	5,059		

* TS-Mast : Wide Visible 3 Stage Full Free Lift Mast with 2 Free Lift Cylinders.

Load Capacity

25L-7A

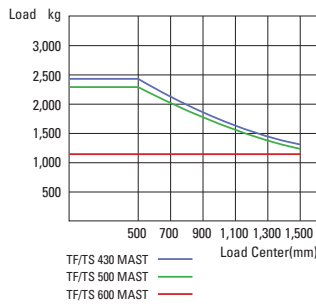
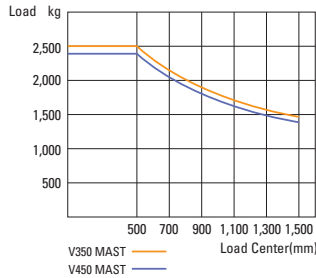

30L-7A

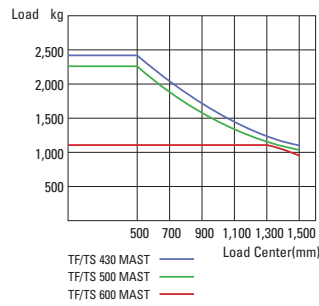
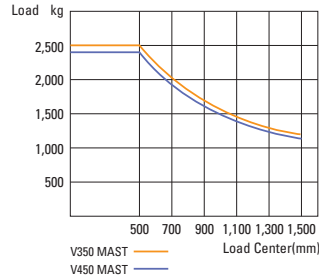

33L-7A

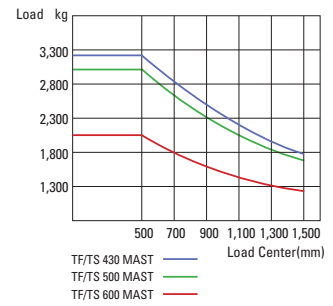
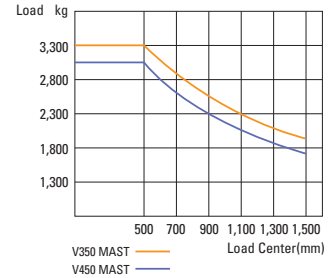

Optional Items

- CABIN & HEATER

- SIDE SHIFT / INTEGRAL SIDE SHIFT

- FORK (L x W x T) (mm)

25L-7A

900 x 100 x 45 1,000 x 100 x 45 1,050 x 100 x 45

1,200 x 100 x 45 1,350 x 100 x 45 1,500 x 100 x 45

1,650 x 100 x 45 1,800 x 100 x 45

30/33L-7A

900 x 122 x 45 1,050 x 122 x 45 1,150 x 122 x 45
 1,200 x 122 x 45 1,350 x 122 x 45 1,500 x 122 x 45
 1,650 x 122 x 45 1,800 x 122 x 45 1,970 x 122 x 45
 2,120 x 122 x 45 2,300 x 122 x 45 2,400 x 122 x 45

- TILTING : 6/6°, 3/3°

- TIRE : No-marking, Double

- SEAT : Pocket, Belt, Arm Rest

- LPG TANK CLAMP : Swing Out, Swing Down

- M.C.V : 4-Spool

- ATTACH PIPING : 3 Spool-piping, 4 Spool-piping

- MASTER SWITCH / HAZARD SWITCH

- BEACON LAMP / WORK LAMP

- TRAVEL SPEED CONTROL SENSOR

- TS-MAST

- PRECLANER

Dimension

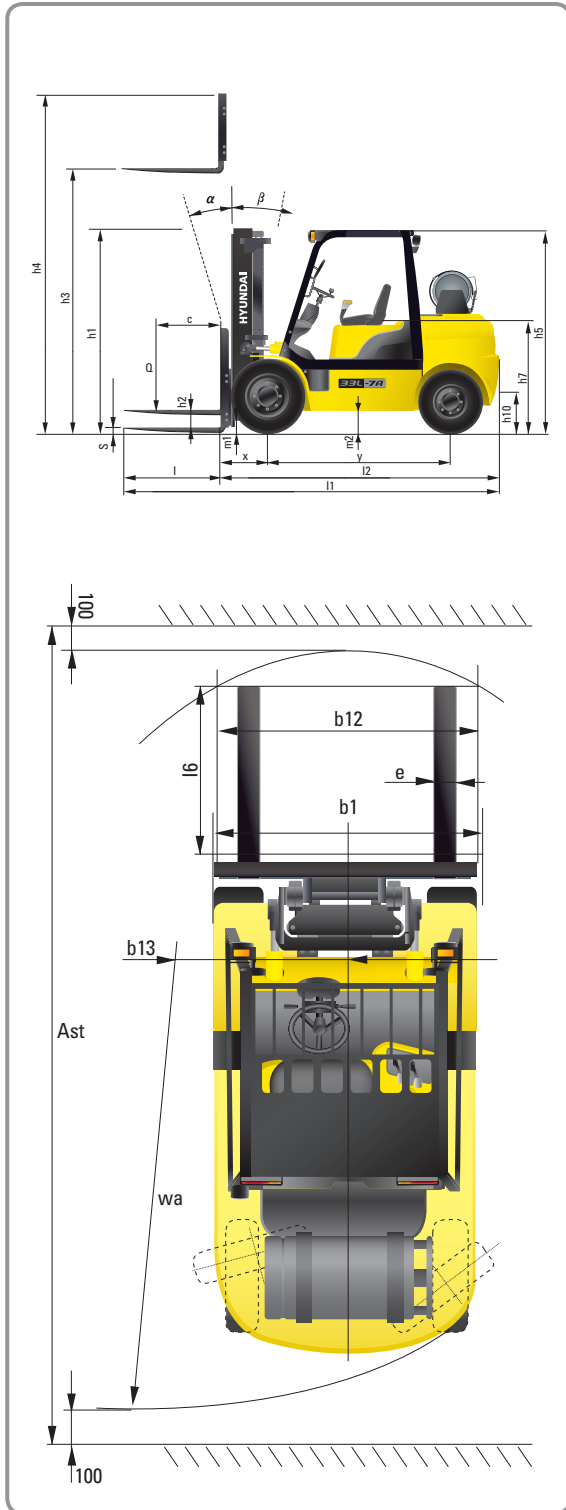

Specification

Identification			
1.1	Manufacturer	Hyundai	Hyundai
1.2	Manufacturer's type designation	25L-7A	30L-7A
1.3	Drive: electric (battery or mains),diesel,petrol,fuel gas,manual	LP	LP
1.4	Type of operation:hand,pedestrian,standing,seated,order-picker	seated	seated
1.5	Load capacity / rated load	Q (kg)	2,500
1.6	Load center distance	c (mm)	500
1.8	Load distance, center of drive axle to fork	x (mm)	468
1.9	Wheelbase	y (mm)	1,650
Weights			
2.1	Service weight	kg	3,706
2.2	Axle loading, loaded front/rear	kg	5,452 / 753
2.3	Axle loading, unloaded front/rear	kg	1,486 / 2,220
Wheels, Chassis			
3.1	Tires:solid rubber, superplastic, pneumatic, polyurethane	Pneumatic	Pneumatic
3.2	Tires size, front	7.00 - 12 - 12PR	8.15 x 15 - 14PR
3.3	Tires size, rear	6.50 - 10 - 12PR	6.50 - 10 - 12PR
3.5	Wheels, number front x rear (x = driven wheels)	2 x 2	2 x 2
3.6	Track width, front	b10 (mm)	965
3.7	Track width, rear	b11 (mm)	980
Basic Dimensions			
4.1	Mast / fork carriage tilt forward / backward(α / β)	degrees	6 / 10
4.2	Lowered mast height	h1 (mm)	2,175
4.3	Free lift	h2 (mm)	155
4.4	Lift height	h3 (mm)	3,300
4.5	Extended mast height	h4 (mm)	4,485
4.7	Overhead load guard (cab) height	h5 (mm)	2,160
4.8	Seat height / standing height	h7 (mm)	1,169
4.12	Coupling height	h10 (mm)	283
4.19	Overall length	l1 (mm)	3,644
4.20	Length to face of forks	l2 (mm)	2,594
4.21	Overall width	b1 (mm)	1,160
4.22	Fork dimensions	l / e / s (mm)	1,050 x 100 x 45
4.23	Fork carriage ISO 2328, class / type A,B	II / A	III / A
4.24	Fork-carriage width	b12 (mm)	1,102
4.31	Ground clearance, loaded, under mast	m1 (mm)	130
4.32	Ground clearance, centre of wheelbase	m2 (mm)	171
4.33	Aisle width for pallets 1000 x 1200 crossways	Ast (mm)	3,966
4.34	Aisle width for pallets 800 x 1200 lengthways	Ast (mm)	4,166
4.35	Turning radius	Wa (mm)	2,298
4.36	Smallest pivot point distance	b13 (mm)	714
Performance Data			
5.1	Travel speed, Unloaded	km/h	17.7
5.2	Lift speed, Loaded/Unloaded	mm/s	600 / 610
5.3	Lowering speed, Loaded/Unloaded	mm/s	500 / 450
5.6	Max. Drawbar pull, Loaded	N	23,660
5.8	Max. Gradeability, Loaded	%	37.1
5.10	Service brake		Hydraulic
Engine			
7.1	Engine manufacturer / type		HMC L4KB
7.2	Engine power acc. to ISO 1585	kW/rpm	44 / 2,300
7.3	Maximum torque	kgf-m/rpm	19.1 / 1,800
7.4	No. of cylinder / cubic capacity	/cm³	4 / 2,359
Other Details			
8.1	Type of drive control		Power Shift
8.2	Operating pressure, system / attachments	bar	217 / 162
8.3	Oil volume for attachments	ℓ / min	30 (60max)
8.4	Sound level at the driver's ear according to DIN 12053	db(A)	79



www.hyundai-mh.com