

## **USER MANUAL**

# **HIGH VOLTAGE INSULATION TESTERS**

**S-24 VLF • S-36 VLF • S-44 VLF • S-57 VLF**





## **USER MANUAL**

# **HIGH VOLTAGE INSULATION TESTERS**

**S-24 VLF • S-36 VLF • S-44 VLF • S-57 VLF**



**SONEL S.A.  
Wokulskiego 11  
58-100 Świdnica  
Poland**

Version 1.04 06.07.2023

The S-24 / 36 / 44 / 57 VLF meters are modern, easy in use and safe testing devices. Please acquaint yourself with this manual in order to avoid measuring errors and prevent possible problems in operation of the testers.

# CONTENTS

<b>1 Safety</b> .....	<b>4</b>
1.1 General safety regulations .....	5
1.2 Warnings .....	6
<b>2 Overview and functions</b> .....	<b>7</b>
2.1 Design of the set .....	7
2.2 Functionality .....	7
2.3 Application .....	8
2.3.1 VLF testing .....	8
2.3.2 DC testing .....	10
2.3.3 Cable Sheath – Testing .....	10
<b>3 Preparation for use</b> .....	<b>11</b>
3.1 Operating requirements .....	11
3.2 Connecting the test equipment .....	12
3.3 Avoiding radio interference .....	14
<b>4 Operating the device</b> .....	<b>15</b>
4.1 Controls and displays .....	15
4.2 Menu control via alphanumerical display .....	16
4.3 Operating procedure .....	17
4.3.1 Testing with alternating voltage (VLF) .....	17
4.3.2 Testing with direct voltage (DC) .....	20
4.3.3 Terminating the test .....	22
4.3.4 Safety measures .....	23
4.3.5 Operating hour counter .....	23
4.3.6 Data Recording (Option) .....	23
<b>5 Maintenance and repair</b> .....	<b>26</b>
5.1 Maintenance and service .....	26
5.1.1 Maintenance by user .....	26
5.1.2 Manufacturer's service .....	26
5.2 Important transport directions .....	27
<b>6 Troubleshooting</b> .....	<b>27</b>
<b>7 Technical specifications</b> .....	<b>28</b>
7.1 S-24 VLF .....	28
7.2 S-36 VLF .....	29
7.3 S-44 VLF .....	30
7.4 S-57 VLF .....	31
<b>8 Accessories</b> .....	<b>32</b>
8.1 Standard accessories .....	32
8.2 Optional accessories .....	32
<b>9 Manufacturer</b> .....	<b>32</b>

# 1 Safety

The cable test set is a device used to generate high voltages. It may be used for voltage proof testing of the insulation of cables, electrical installations and items of equipment. By measuring the current and voltage by means of integrated measuring devices, the insulation resistance of the equipment under test can be determined.

The tester is comprised of an operating unit and a high-voltage unit. Thanks to its small dimensions and a relatively low weight, it is portable and can be used directly at the equipment to be tested. Clearly arranged control elements and indicators as well as a simple menu-prompted operation ensure comfortable handling.

A special ground safety circuit provides for a high degree of safety.

Any person intending to install, operate, maintain or repair this unit must have carefully read this manual and understand the information given therein.

At the time of delivery, the device and its accessory equipment represent the state of the art in the area of safety technology. However, due to the specific nature of operations, there may exist points and parts on the unit and its associated peripheral equipment, which cannot be fully protected without unreasonably affecting its function and operation. Consequently, appropriate personal safety practices are indispensable for preventing harm to personnel and the unit itself.

## **The following safety hints must be duly observed!**

- General instructions
  - ⇒ Only duly qualified, trained and / or instructed personnel shall be allowed to perform work on this unit and its peripheral equipment. Access to the unit and equipment by other persons must be prevented.
  - ⇒ This manual must be kept available to supervising, operating and maintenance personnel for ready reference.
  - ⇒ Using the device in a way which is not in conformity with the intended purpose may be dangerous to health and life, to the unit and associated equipment, and may also affect its appropriate use. The unit may exclusively be used for the purpose for which it has been designed by the manufacturer.
  - ⇒ It is unacceptable to operate:
    - a damaged meter which is completely or partially out of order,
    - leads with damaged insulation,
    - a meter stored for an excessive period of time in disadvantageous conditions (e.g. excessive humidity).
  - ⇒ Carry out checks on a regular basis to make sure that safety regulations are complied with during operation and maintenance.
  - ⇒ The device may be operated only by authorised, appropriately qualified persons.
  - ⇒ The device and the associated peripheral equipment must at all times be in an impeccable condition in technical respect.
  - ⇒ Only genuine parts may be used in the device and the associated peripheral equipment, because non-original parts may endanger the required safety. It is not permitted to handle or operate the device in any way which may affect its safety.
  - ⇒ The person using the device shall be obliged to immediately report to the competent supervisor any changes noticed on the device.
  - ⇒ The operator shall also be obliged to put the device immediately out of operation if an incident occurs which may affect the safety of personnel. The device may be put back into operation only after the cause of the incident has been eliminated.
- Electrotechnical instructions
  - ⇒ The device and all accessory equipment must be connected in conformity with the applicable regulations.

- ⇒ Before starting any repair or maintenance work on the device or other equipment, be sure to isolate it from the power supply (verify equipment is dead). Only qualified electricians may carry out such work. A qualified electrician is a person who, due to its training, knowledge and experience as well as familiarity with applicable regulations, is in a position to assess the work to be performed and to identify possible hazards.
- Instructions to radio interference
  - ⇒ The tester is a device of class A to EN 55011. Radio interference may occur when the „VLF“ test method is used. In this case, the operator of the device will have to carry out protective measures (see **sec. 3.3 Avoiding radio interference**).

## 1.1 General safety regulations

Maintenance and repair work shall primarily be governed by the relevant accident prevention regulations.

- Mark components before starting repairs.
- When reassembling fittings and devices, always use only new gaskets and locking elements.
- Fit screwed connections only in dry condition (use no lubricants).
- Only duly trained and qualified personnel may be assigned for performing maintenance and repair operations.
- Check system for proper functioning after each maintenance and repair work.
- Isolate and secure the equipment.
- Before carrying out any work on electrical equipment, isolate the parts on which work is to be performed. This also applies to seemingly minor repairs.
- Before connecting the device to the tested object, make sure that the object is not live. Perform the check with a voltage tester or measuring instrument (i.e. acoustic-optic indicator placed on a insulating stick), the serviceability of which has been checked shortly before use on a live part of the equipment.
- Take effective measures to prevent unintentional energising of the point(s) isolated.
- Fuses
  - ⇒ It is not permitted to rewire or bridge fuses and to use rewired fuses.
  - ⇒ If fuses have to be replaced, only fuses of the same or lower design current and type (slow, quick-acting, superfast) may be used.
  - ⇒ Any modifications not authorized by the manufacturer are forbidden.
  - ⇒ Fuses must not be disconnected or withdrawn under load. It is not permitted to use fuses for switching circuits.
- Instructions for handling permanently installed and flexible cables and leads
  - ⇒ Mains cables and their clamps must not be used for fastening, attaching or suspending devices, clothing and the like.
  - ⇒ When disconnecting cables, protect them against kinking. Take measures to prevent ingress of moisture at ends of cables. Provide a suitable moisture protection, if necessary.
  - ⇒ During operation and transportation of the devices, make sure that loose supply cables will not be subjected to impermissible pull. Never suspend the devices on the supply cables and, when disconnecting plugs, never pull on the cable for pulling them out of the socket outlet.

- Exploitation instructions of flexible cables and wires included with the device
  - ⇒ Wires that control the HV unit are permanently fixed to the control unit.
  - ⇒ Portable electrical equipment may be connected to the power supply only via the connectors (plug, socket outlet) provided for this purpose.
  - ⇒ It is not permissible to use adapters and plugs fitting into socket outlets for other voltage levels.
  - ⇒ When exchanging cable connections, make sure that connection is made in correct phase sequence.
- Regulations for handling cable accessories
  - ⇒ Secure cable clamps by retaining washers and spring lock washers against becoming loose by vibrations. When reconnecting cables to devices and equipment, make sure the cable shield is earthed and that the cable entry fitting is tight (in accordance with degree of protection of pertaining device).

## 1.2 Warnings

Important instructions relating to personal and operational protection as well as to technical safety are identified as follows in the text:



### WARNING

**This symbol appears whenever working instructions and procedures must be strictly observed to avoid harm to persons. Non-observance may result in serious personal injury or death and/or damage to the unit.**



### NOTE!

This symbol appears whenever working instructions and procedures must be strictly observed to avoid damage to or destruction of the unit and/or associated equipment.



Appears whenever it is necessary to draw your attention to certain technical requirements to be observed when working with the unit.



## 2 Overview and functions

### 2.1 Design of the set

The Cable Test Set consists of the operating unit and high-voltage unit.

The high-voltage unit accommodates the following oil-insulated devices: high-voltage transformer, high-voltage switch, rectifier, measurement divider and discharge device. The bottom region of the unit contains an oil-to-air heat exchanger with forced circulation.

Both devices of the unit are connected by a control cable, which is permanently connected to the operating unit.

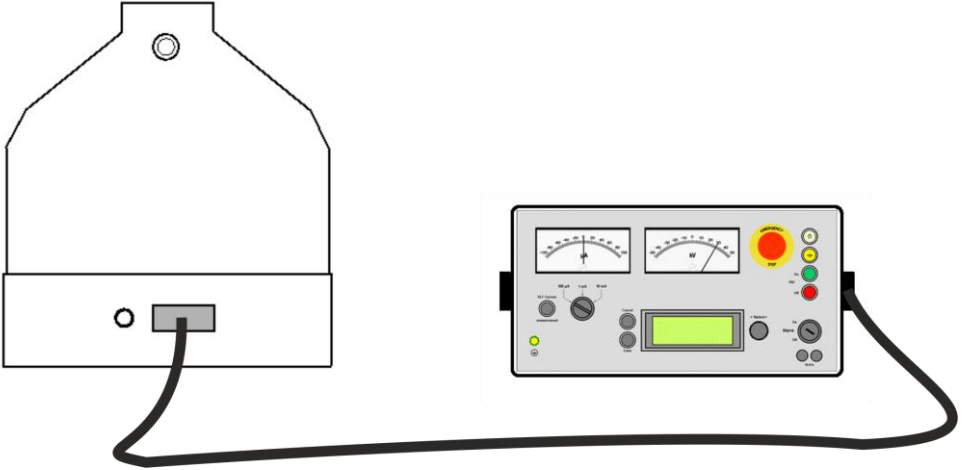

Fig. 2.1 View of high-voltage unit (left) and operating unit (right)

### 2.2 Functionality

For operating the device, the operating unit and the high-voltage unit must be properly grounded. The unit is provided with an internal grounding safety circuit which allows the unit to be operated only if a sufficient low-resistance connection exists between the protective ground and station ground.

The device has a number of further protective functions such as mains voltage monitoring and power-on disable if a residual or external voltage is present at the output. Only when all specified parameters are met, the high-voltage can be turned on.

The design provides for redundancy of all important safety functions.

In the **high-voltage unit**, the test voltage is generated by means of a high-voltage transformer, rectifier and high-voltage switch. This voltage may either be a low-frequency alternating voltage (0.1 Hz) or a direct voltage of positive or negative polarity.

On completion of a test or tripping of a protective device, the connected equipment under test is also automatically discharged via the discharge device, which is also integrated in the high-voltage unit.

## 2.3 Application

The portable Cable Test Set is mainly used for insulation testing of Medium Voltage Power Cable Systems. A sheath test can be performed with this device too.

Fields of application include:

- testing of newly fit cables prior to commissioning,
- re-commissioning after repair and maintenance,
- re-commissioning of temporarily shut-down cables,
- regular preventive testing.

It can be tested with the following test methods:

- VLF (0.1 Hz AC voltage testing),
- DC testing.

The test methods are described in more detail.

### 2.3.1 VLF testing

Suitable for:

- MV-Cables with plastic insulation (XLPE, PE, EPR, HEPR),
- MV-Cables with Paper-Oil-Insulation (PILC),
- mixed cables.

**Requirements of IEC 60502-2, CENELEC HD 620 S1, DIN VDE 0276-620 and DIN VDE 0276-621 for voltage test on the insulation:**

Frequency of testing voltage:	0.1 Hz
Testing voltage:	$3 \times U_0$ RMS value*
Testing time:	15 minutes (IEC 60502-2) 60 minutes (CENELEC HD 620 S1)
Requirement:	no breakdown

Cable rating $U_0 / U^*$	VLF test Voltage $U_{test}$
3.8 / 6.6 kV	11.5 kV <sub>RMS</sub> / 0.1 Hz
6 / 10 kV	18 kV <sub>RMS</sub> / 0.1 Hz
6.35 / 11 kV	19 kV <sub>RMS</sub> / 0.1 Hz
8.7 / 15 kV	26 kV <sub>RMS</sub> / 0.1 Hz
12 / 20 kV	36 kV <sub>RMS</sub> / 0.1 Hz
12.7 / 22 kV	38 kV <sub>RMS</sub> / 0.1 Hz
18 / 30 kV	54 kV <sub>RMS</sub> / 0.1 Hz
19 / 33 kV	57 kV <sub>RMS</sub> / 0.1 Hz

\*  $U_0$  = cable rating phase to ground  
 $U$  = cable rating phase to phase

VLF is the very best and most effective method for insulation testing of medium voltage power cables with extruded (plastic) insulation.

Using 0.1 Hz VLF test voltage, weak spots in XLPE, PE and also oil impregnated paper insulated cables are quickly brought to a controlled breakdown without causing additional damage or aging to the remaining cable insulation.

**Other VLF standards. Requirements of the IEEE 400.2™-2013**

VLF test voltage for sinusoidal waveform:

<b>Cable rating</b>	<b>Installation</b>	<b>Acceptance</b>	<b>Maintenance</b>
phase to phase	phase to ground	phase to ground	phase to ground
RMS voltage	RMS or (peak voltage)	RMS or (peak voltage)	RMS or (peak voltage)
5 kV	9 (13) kV	10 (14) kV	7 (10) kV
8 kV	11 (16) kV	13 (18) kV	10 (14) kV
15 kV	19 (27) kV	21 (30) kV	16 (22) kV
20 kV	24 (34) kV	26 (37) kV	20 (28) kV
25 kV	29 (41) kV	32 (45) kV	24 (34) kV
28 kV	32 (45) kV	36 (51) kV	27 (38) kV
30 kV	34 (48) kV	38 (54) kV	29 (41) kV
35 kV	39 (55) kV	44 (62) kV	33 (47) kV
<b>Conversion for other system voltages, which are not mentioned in this standard:</b>			
6.6 kV	10 (14) kV	11 (16) kV	9 (13) kV
11 kV	14 (20) kV	15.5 (22) kV	12 (16) kV
13.8 kV	17.5 (25) kV	19.5 (27.5) kV	15 (20) kV
22 kV	26.5 (37.5) kV	28.5 (40.5) kV	22 (31) kV
31.5 kV	35.5 (50.5) kV	40 (56.5) kV	30.5 (43) kV
33 kV	37 (52) kV	41.5 (58.5) kV	31 (44.5) kV
34.5 kV	38.5 (54) kV	43.5 (61) kV	32.5 (46.5) kV

### 2.3.2 DC testing

Suitable for:

- MV-Cables with Paper-Oil-Insulation (PILC).

#### Requirements of CENELEC HD 621 standards for voltage test across the insulation:

Testing voltage: see table  
 Testing time: 15 to 30 minutes  
 Requirement: no breakdown shall occur during testing period

<b>Cable rating <math>U_0 / U</math></b>	3.6 / 6 kV	6 / 10 kV	8.7 / 15 kV	12 / 20 kV
<b>DC-Test voltage</b>	20-29 kV	34-48 kV	52-69 kV	67-96 kV
<b>max. permissible leak-age current (per core)*</b>	500 $\mu$ A/km	700 $\mu$ A/km	700 $\mu$ A/km	700 $\mu$ A/km

\* Practical values, not required in the standard.

DC-Polarity: Testing voltage on conductor: negative  
 Cable shield on station ground: positive

### 2.3.3 Cable Sheath – Testing

Suitable for:

- MV-Cables with PE or PVC-Sheath (Jacket).

#### Requirements of CENELEC HD 620 for voltage test across cable sheath (jacket):

PVC-Sheath:  $\leq 3$  kV DC voltage  
 PE-Sheath:  $\leq 5$  kV DC voltage  
 Testing time: 10 minutes (practical value)  
 Requirement: no breakdown shall occur during testing period

Limits for leakage currents\*:

PVC at 3 kV: max. 800  $\mu$ A / km  
 PE at 5 kV: max. 20  $\mu$ A / km

\* Practical values, not required in the standard.

Polarity: Cable shield on negative potential,  
 Station ground on positive potential

## 3 Preparation for use

### 3.1 Operating requirements

It is not permissible to leave the operating unit in the protective bag during operation of the unit. Make sure that the device is adequately ventilated. Do not cover the ventilation slots. After putting down the device carrying handle can be locked in 30°-steps by using spring bias. Pulling on handle unfixes the lock. The operating unit may be operated either in the vertical position (with the operator panel facing upwards) or in the horizontal position (with the operator panel facing towards the front).

The connecting cables are kept in the front pocket. When packing in the cables, in particular the high-voltage connection cable, make sure that it will not be kinked.

**The high-voltage unit must always be set up in the vertical position** and secured during operation against inadvertent contact. Make sure that the high-voltage device is placed on a clean surface so that it is protected from dirt and moisture and that no foreign matter may get into the air intake and outlet openings.



#### WARNING

**Strictly ensure that the clearances between the high-voltage terminal and grounded or live parts are kept in accordance with EN 50191 standard.**



#### NOTE!

During the test, warning signs with the text:

**HIGH VOLTAGE!**

**Caution! Danger to Life!**

must be put up, and the area of testing must be cordoned off with a barrier. Set up the operating unit at a distance of approx. 3 m from the barrier. It should preferably be set up on a surface which is at operating height (0.8...1.0 m).

### 3.2 Connecting the test equipment

Before connecting the device, make sure that the oil level can be seen in the middle of the oil-level lens ②. If this is not the case, it is not permitted to carry out measurements.

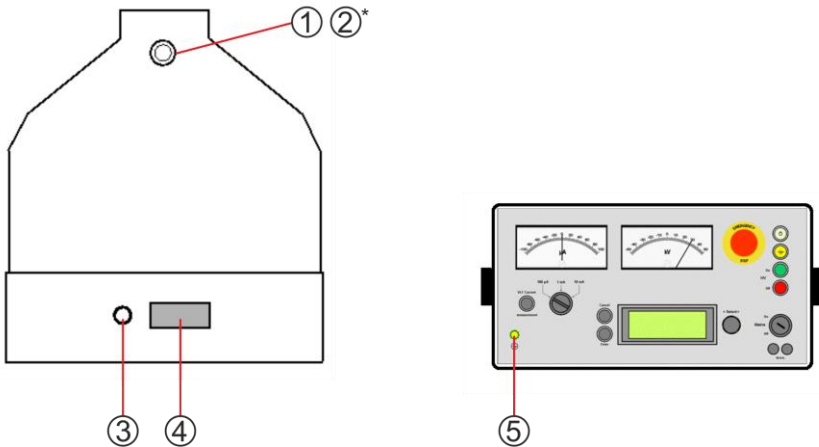

Fig. 3.1 Tester connections

- ① High-voltage connection socket
- ②\* On rear side: oil-level lens
- ③ Ground terminal of high-voltage unit (station ground)
- ④ Socket for cable connecting operating unit to high-voltage unit
- ⑤ Ground terminal of operating unit (protective ground)

Before connecting the test device, isolate and secure the equipment in conformity with EN 50110-1. The requirements of EN 50191 and EN 50110-1 must be met. To connect the device, carry out the following steps in the order given:

- ① Ground and short-circuit the test object conductors which will not be tested as well as the cable shield (connect to station ground or auxiliary earth point). The device can be used for testing of unearthed equipment only, if an auxiliary earth is created.
- ② Establish a conductive connection between the station ground or auxiliary earth and the ground terminal of the high-voltage unit ③.
- ③ **Establish a connection between the ground terminal of the operating unit ⑤ and the protective ground (PE) potential**

If the device is powered by Mains Voltage from a grounded Mains Socket, there is no need of additional grounding by the green/yellow protection ground cable! That's important to avoid ground-loops.

Only if the equipment is powered by an isolated (earth-free) Mains, then the control unit must be connected to an auxiliary earth (e.g. earth spike) by means of the green-yellow protection ground cable!

- ④ Establish the connection between the high-voltage terminal ① and the test objects conductor which will be tested. To this end, plug high-voltage plug into high-voltage connection socket ① and screw it in place.
- ⑤ Connect the connecting cable, which is permanently fitted to the operating unit, to the high-voltage unit (connection socket ④). Connect operating unit to the power supply.



If the device is powered by Mains Voltage from a grounded Mains socket (the yellow control light lights on), there is no need of additional grounding by the green/yellow protection ground cable. That's important to avoid ground loops.

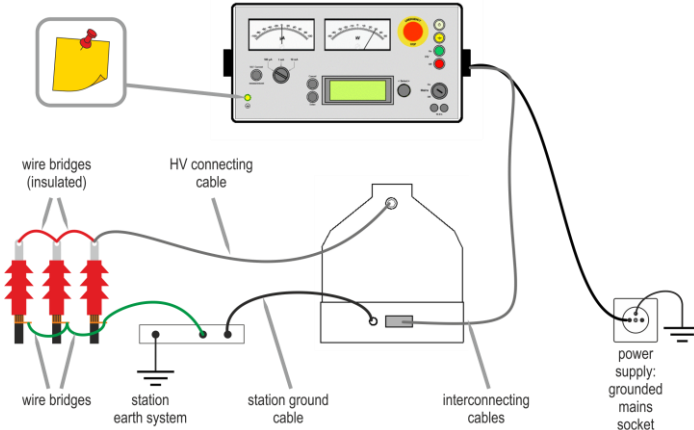

**Fig. 3.2 Connecting the test equipment for insulation testing: of a 3x single-core system or a three-core cable with separate shield on each core**

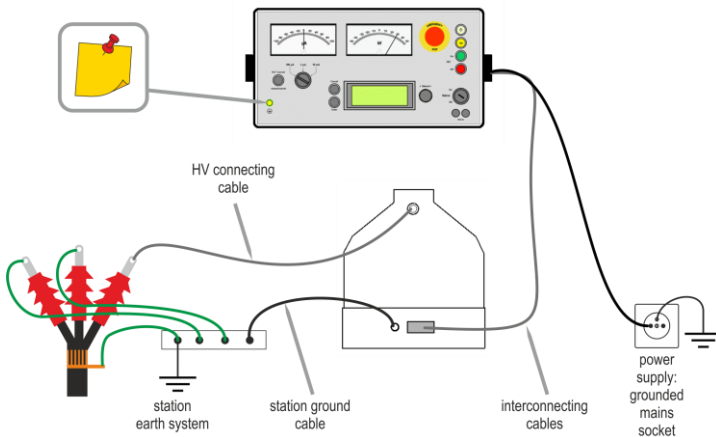

**Fig. 3.3 Connecting the test equipment for insulation testing of a three-core cable with only one common shield (e.g. PILC)**

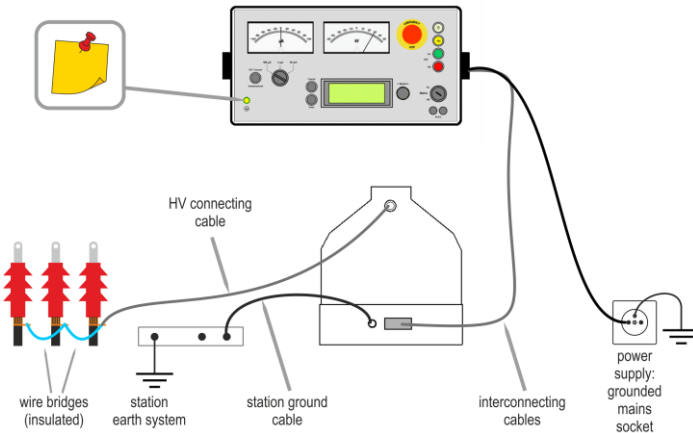

**Fig. 3.4 Connecting the test equipment for sheath testing of a 3x single-core system. The sheaths of all three cores can be tested at the same time. The cable shields at the other end of the cable must be disconnected from ground too!**



**NOTE!**

- Before testing, measuring voltage transformers and power transformers must be disconnected!
- Ending the cable in an enclosed switchgear, so this test requires the agreement of the contracting authority with the manufacturers of switchgear.

### 3.3 Avoiding radio interference

The tester is a device of class A to EN 55011. Radio interference may occur when the „VLF“ test method is used. In this case, the operator of the device will have to carry out the following protective measures:

- ① Before starting measurements or tests, check whether in the near-by area there are any facilities sensitive to radio interference such as:
  - ⇒ transmitting facilities,
  - ⇒ receiving facilities,
  - ⇒ personnel and building protection facilities,
  - ⇒ air traffic radio installations,
  - ⇒ medical facilities,
  - ⇒ residential buildings,
 and advise the parties in question that there may be radio interference or that electronic equipment may be affected. Such checks and the notification of parties affected should be documented each time the unit is to be used.
- ② If need be, increase the distances between the unit and the cable to be checked and the facility which will possibly be affected.
- ③ Generally, when using the unit in industrial facilities, make sure that a protective distance of 30 m to radio-sensitive facilities is maintained.
- ④ Generally, when using the unit in residential areas, make sure that a protective distance of 60 m to radio-sensitive facilities is maintained.



## 4 Operating the device

### 4.1 Controls and displays

The controls and displays needed to operate the tester are on the front of the operation unit.

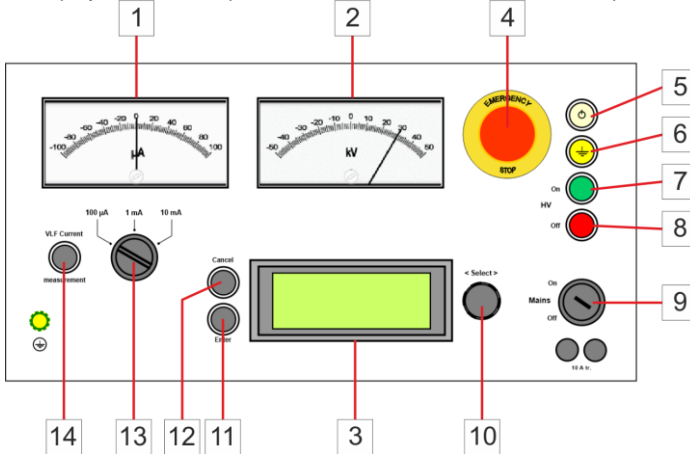

Fig. 4.1 Interface

- 1 **Ammeter**
  - indicates leakage current
  - measuring ranges:  $\pm 100 \mu\text{A}$  /  $\pm 1 \text{mA}$  /  $\pm 10 \text{mA}$
- 2 **Voltmeter**
  - indicates output voltage (instantaneous value)
  - operate even when the mains power is interrupted
- 3 **Alphanumerical display**
  - 4 x 20 characters (yellow, black background)
  - industrial grade OLED-type, perfectly readable in dark and in sunshine
  - functions: see **sec. 4.2 Menu control via alphanumerical display**
- 4 **EMERGENCY STOP button**
  - slam button for interrupting main circuit (mains supply)
  - with turn-left-to-reset feature
  - ON-OFF indication by green marking ring
  - causes immediate activation of discharge device
- 5 **Signal lamp „Power ON“ (white)**
  - illuminates when the device has been switched on with the mains switch 9 and mains voltage is applied

- 6 **Signal lamp „Ground connection“ (yellow)**
  - illuminates when operating device and high-voltage device are properly grounded
- 7 **Illuminated pushbutton „HV On“ (green)**
  - button for switching on high voltage
  - illuminates when ready for switching on
- 8 **Illuminated pushbutton „HV Off“ (red)**
  - button for switching off high voltage
  - illuminates when high voltage is switched on
- 9 **Mains switch „Mains“**
  - key-operated switch; key may be pulled off only at Off position
- 10 **Rotary encoder for function selection and parameter input**
  - incremental encoder without end stop
  - turning it counterclockwise/clockwise will shift the cursor or change a parameter
- 11 **„Enter“ button for menu control**
  - button for correcting a selected function or a selected parameter
- 12 **„Cancel“ button for menu control**
  - button for correcting a selected function or a selected parameter
- 13 **Range selector switch for ammeter**
  - 3-stage rotary switch for selecting the measuring range for the leakage current
- 14 **„VLF current measurement“ button**
  - function: see **sec. 4.3.1 Testing with alternating voltage (VLF)**

## 4.2 *Menu control via alphanumerical display*

The dialogue between the user and the control of the device is via the alphanumerical display. It serves for menu-prompted parameterising of the device. During a measurement, it provides information on the most important measuring variables and displays possibly occurring faults.

Thanks to the simple structure of the menu, the user can determine the required test parameters in just a few steps.

The entire selection of functions and parameterisation are performed with the rotary encoder [**< Select >**] and the buttons [**Enter**] and [**Cancel**]. Turning the rotary encoder counterclockwise or clockwise, as appropriate, will shift the cursor (highlighting of a function) or change a parameter. The rotary encoder has no end stop.

Pressing the button [**Enter**] will acknowledge a selected function or a selected parameter. That is, you get to the next menu level.

By pressing the button [**Cancel**], you can cancel the selection of a function or of a parameter. Each time you press this button will bring you one further level back in the menu.

## 4.3 Operating procedure

Before each measurement, select the greatest current measuring range (10 mA).

Switch on the mains switch **[Mains]**. The white signal lamp illuminates. At the same time, the yellow signal lamp illuminates if grounding has been carried out properly and if connection to ground exists. If the lamp does not illuminate, check all grounding connections.

On the display the start screen and. After a few seconds, the main menu appears.

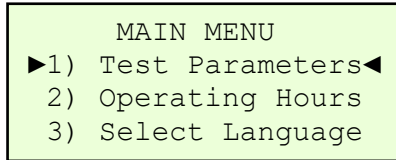

In menu item „3) Select Language“, you can select the language to be used for menu control.

### 4.3.1 Testing with alternating voltage (VLF)

① [Enter] Select „1) Test Parameters“ in the main menu (see above).

② Select test method „VLF“.

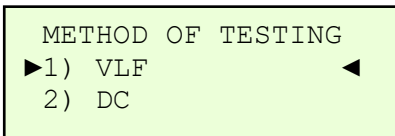

[Enter]

③ Select frequency of VLF voltage (option, not installed on all devices!).

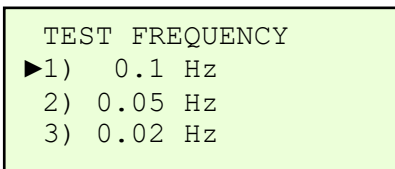

[Enter]

④ Select test voltage (RMS value). VLF test voltage can be chosen between 5 kV to maximum in 0.5 kV-steps.

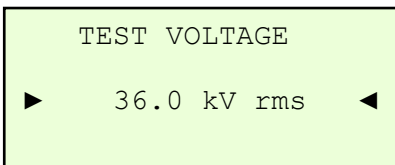

[Enter]

⑤ Set test time.  
The maximum test time is 300 min.

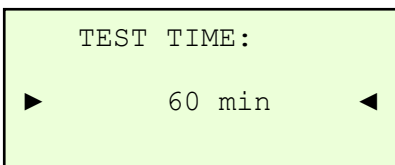

[Enter]

6

```

DATA RECORDING:
▶1) Yes ◀
2) No

```

[Enter]

Data recording (option - not installed on all devices). Select whether the test data should be recorded and stored in the built in memory of the device or not.

```

Test between:
▶1) L1 » L2 L3 E ◀
2) L2 » L1 L3 E
3) L3 » L1 L2 E
4) L1 L2 L3 » E
5) L1 L2 » L3 E
6) L1 L3 » L2 E
7) L2 L3 » L1 E
8) *S L1 » E
9) *S L2 » E
10) *S L3 » E
11) *S L1 L2 L3 » E

```

[Enter]

Measurement configuration of phases of the measured object. E.g.:

- **L1 » L2 L3 E** means insulation test of phase L1 against Ground, L2 and L3 grounded,
- **L1 L2 L3 » E** means insulation test of all 3 phases against Ground,
- **\*S L1 » E** means sheath test, cable shield of L1 against Ground.

7

```

VLF Test
Frequency: 0.1 Hz
Voltage: 36.0 kV
Test time: 60 min

```

Display of selected test parameters. Acknowledge parameters with **[Enter]** or correct with **[Cancel]**.

8

```

Start with:
[HV On]

```

The green illumination pushbutton **[HV On]** signals readiness for switch on.

9

Operate button **[HV On]**. The high-voltage is connected, the discharge switch opens. The red illuminated pushbutton **[HV Off]** illuminates and signals „High voltage is on“. At the same time, the green illuminated pushbutton extinguishes.

10

Load Test!  
1.9  $\mu$ F

The device automatically carries out a load test in which the capacity of the tested object is determined internally.

Output voltage:  
36.0 kV rms 0.1 Hz  
Test time:  
21:16 of 060 min

If the load capacity is within the permissible range (see **sec. 7 Technical** specifications), the VLF test will now start automatically.

The measured output voltage is displayed as true RMS value in the upper area of the screen.

In the lowermost display line, the selected test time and test time that has already expired are indicated.

11

**Leakage current measurement**

During the VLF test the ammeter is disabled. Otherwise the charging current and not the leakage current would be displayed.

But during the VLF test, you can also measure the leakage current. To this end, press the button **[VLF Current measurement]**.

The VLF test will then be continued up to the next negative voltage half-wave. Shortly before the peak voltage is reached, the device stops to activate the ammeter. After a few seconds, the leakage current can be read. If need be, the current measurement range has to be changed with the selector switch.



After completing the measurement, do not forget to select again the greatest measurement range (10 mA). The leakage current measurement is automatically completed after 30 seconds. However, you can also prematurely abort the measurement by pressing the button **[VLF Current measurement]**. The VLF test will then be automatically resumed.

12

Breakdown!  
  
after 011:13 min  
at 36.0 kV

**Breakdown detection**

If the test object is damaged or defective, the insulation will be punctured during the test, the breakdown will be automatically detected and the time at which the breakdown occurred determined.

13

See **sec. 4.3.3 Terminating the test.**

### 4.3.2 Testing with direct voltage (DC)

1

```
METHOD OF TESTING
1) VLF
▶2) DC ◀
```

Select test method „DC“.

[Enter]

2

```
DC - POLARITY:
▶1) negative ◀
2) positive
```

Select polarity of direct voltage.

[Enter]

3

```
TEST TIME:
▶ 045 min ◀
```

Set test time.

The maximum test time is 300 min.

[Enter]

4

```
DATA RECORDING:
▶1) Yes ◀
2) No
```

**Data recording (Option, not installed on all devices!)**

Select whether the test data should be recorded and stored in the built in memory of the device or not.

[Enter]

```
Test between:
▶ 1) L1 » L2 L3 E ◀
2) L2 » L1 L3 E
3) L3 » L1 L2 E
4) L1 L2 L3 » E
5) L1 L2 » L3 E
6) L1 L3 » L2 E
7) L2 L3 » L1 E
8) *S L1 » E
9) *S L2 » E
10) *S L3 » E
11) *S L1 L2 L3 » E
```

Configure, between phases is tested. e.g.

- **L1 » L2 L3 E** means insulation test of phase L1 against Ground, L2 and L3 grounded
- **L1 L2 L3 » E** means insulation test of all 3 phases against Ground
- **\*S L1 » E** means sheath test, cable shield of L1 against Ground

[Enter]

5

DC Test  
Polarity: negative  
Test time: 45 min

- Display the selected test parameters.
- Confirm parameters with **[Enter]** or cancel with **[Cancel]**.

6

Start with:  
[HV On]

The green illuminated pushbutton **[HV On]** signals readiness for connection.

7

Output Voltage:  
38.4 kV  
Test time:  
1:04 of 45 min

- Operate the button **[HV On]**. High voltage is connected, the discharge switch is opened.
- The red illuminated pushbutton **[HV Off]** illuminates and signals „High voltage is on“. At the same time, the green illuminated pushbutton extinguishes.
- To set the test voltage, slowly turn the rotary encoder **<Select>** clockwise (100 V steps). While doing so, observe the rise of voltage and current on the instruments.
- The voltage can be read on both the analogue instrument and on the display.
- After the predetermined test voltage is reached, select the current measuring range with the selector switch. Now you can read the leakage current of the test object on the ammeter.

Overcurrent Trip!  
  
after 11:13 min  
at 47.8 kV

When the maximum output current is exceeded (10 mA), the overcurrent release trips. Tripping of the overcurrent release indicates that the test object is defective.

When the nominal test voltage of the device is exceeded, the overvoltage release trips. Voltage thresholds:

- S-24 VLF: 34.5 kV,
- S-36 VLF: 52.5 kV,
- S-44 VLF: 62.5 kV,
- S-57 VLF: 62.5 kV.

### 4.3.3 Terminating the test

You can terminate testing at any time (by hand):

- by operating the button **[HV Off]**. The message: „End of Test“ appears,
- in case of emergency by pressing the **EMERGENCY STOP** button.

The test ends automatically upon expiration of the test duration. Message: „Test Timeout“

Testing is also automatically terminated when a fault occurs. The following error messages may occur:

- NO EARTH!
- Supply-Undervoltage!
- OVERVOLTAGE!

In a VLF test:

- Short circuit
- Breakdown! → Test object defective

In a DC test:

- Primary Overcurrent!
- Overcurrent Trip! → Test object defective

Any time testing is terminated (manually or automatically), the high voltage will be automatically switched off (red signal lamp **[HV Off]** extinguishes), and the discharge device is activated.

You can follow the discharge operation on the voltmeter. When the high-voltage reading has dropped to 0 volt, the test object can be grounded.



If testing at a large load has been carried out for a long time, the unit should be left switched on (only **[Mains On]** !) for an adequate period of time (5-10 min). The cooling system of the high-voltage unit will then remain active and provide for rapid cooling of the transformer oil and enclosure.

After grounding and switching off the device, you can disconnect the connection to the test object.



#### **WARNING**

**The high-voltage plug must not be plugged in or pulled in the live condition.**

In case of an emergency, a second operator must switch off the high voltage by actuating the **EMERGENCY STOP** button.



#### 4.3.4 Safety measures

Please refer also to the general safety directions given in **section 1**.

Only qualified electricians according to EN 50110-1 may operate the device. It may be operated only in rooms which are safeguarded or cordoned off and marked in accordance with EN 50191 and EN 50110-1.

In case of an emergency, a second operator must switch off the device by actuating the **EMERGENCY STOP** button or red button **[HV off]** and short-circuit the device.



Never put equipment into operation in the following conditions:

- high humidity,
- condensing water vapour,
- moisture settling the device and measured object.

In addition to an appropriate shock-hazard protection, reliable grounding of the device is required at all times.



#### **WARNING**

**Make sure that the other end of the cable / cables is fenced before unintentional contact by unauthorized persons.**

Always bear in mind when carrying out capacitive tests that residual charges may still be present after discharging.



#### **WARNING**

**Cables laid parallel to one another may also still be charged after testing!**

Before each test, the oil level must be visually checked (oil level in middle of oil-level lens  $\pm 5$  mm).

#### 4.3.5 Operating hour counter

In each test (or at the end of the test), the operating hour counter adds the expired timer minutes to the counter value which is stored. This means that it is not the on-time of the device which is determined but the real sum of test times.

If the interval of service is exceeded, this is signalled by the operating hour counter immediately upon powering up of the device .

Service interval → see **sec. 5.1.2**.

#### 4.3.6 Data Recording (Option)

If the device is equipped with the „Data Recording“ feature. The non-volatile built in memory is able to store about 100 records at 1 h.

Recording of measurement data is already described in **sections 4.3.1** and **4.3.2**.

To transfer data, to delete the internal data memory or setting of the internal clock, please proceed as follows.

1

```

MAIN MENU
1) Test Parameters
2) Operating Hours
3) Select Language
▶4) Data Recording ◀

```

Switch On Operating Unit. The HV Unit does not need to be connected.

In the MAIN MENU select „4) Data Recording“ .

[Enter]

2

```

DATA RECORDING
▶1) transfer Data ◀
2) set Clock
3) delete Data
4) Memory-Info

```

Transfer Data from built in memory to USB Flash Drive.

To transfer data connect the included USB Flash Drive on the side of Operating Unit, then select 1) transfer Data.

[Enter]

```

MEMORY ->> USB

```

„MEMORY->> USB“ indicates that data is copied from device memory to the USB stick. Do not remove the USB stick!

```

TRANSFER OK !

```

„TRANSFER OK!“ confirms that the data was correctly copied to the USB stick. The USB stick can now be removed.

3

```

DATA RECORDING
1) transfer Data
▶2) set Clock ◀
3) delete Data

```

**Setting Date and Time**

Date and time are always displayed on the startup screen when you turn the device on.

The name of each data file consists of the date and time from the start of the Test. This allows easy categorization of the data files by name already.

[Enter]

```

14:37 31.05.2019
      ↑

```

Each of the selected range can be adjusted with <Select>.

With [Enter], the marker moves on next position.

4

```

DATA RECORDING
2) set Clock
▶3) delete Data ◀
4) Memory-Info

```

At Data transfer all stored data files will be copied from built-in memory to the USB Flash Drive. Its content however is not overwritten by new data. If the data files has been successfully copied to a PC, it is recommended to delete the built-in memory of the device.

[Enter]

5

```

DATA RECORDING
2) set Clock
3) delete Data
▶4) Memory-Info ◀

```

Memory-Info displays free device storage space.

[Enter].

```

250 / 256 kB

```

A data file of a 60-minute measurement requires a space of approximately 2.4 kB.



Please use always the included USB Flash Drive for data transfer. With this, we guarantee full functioning. We as manufacturers have successfully tested a wider range of USB Flash Drives market at the time. However, due to the enormous diversity in the market does not ensure total compatibility with all brands.

## 5 Maintenance and repair

The S-24 / S-36 / S-44 / S-57 VLF is a test instrument and must be carefully treated and maintained as such.

Prevent the surface of the device from becoming soiled. Do not expose it to moisture, direct sun radiation and ambient temperatures in excess of 45°C.

### 5.1 Maintenance and service

#### 5.1.1 Maintenance by user

The only repairs which can be performed by the user are the replacement of fuses and lamps in the operating unit. Fuses and incandescent lamps for replacement are provided in the service kit. The operating unit need not be opened for replacement.



#### **WARNING**

**Before carrying out any repair or maintenance work, always disconnect the device from the power supply by pulling the mains plug!**

For exchanging fuses, open the bayonet locks of the fuse holders on the front panel of the unit with a screwdriver. Defective fuses may be exchanged exclusively against fuses of the same type.

For exchanging incandescent lamps, use the lamp puller provided in the service kit. Get hold of cap with lamp puller and pull vertically upwards. Exchange lamp. Position pressure cap in place (do not turn!), and press it in.

It is principally forbidden to carry out repairs on the high-voltage unit. In case of oil leakage, mechanical damage on the enclosure or other visible defects on the high-voltage device, the test may possibly have to be immediately terminated. Any further use of the device is strictly forbidden!

If the tester is defective, you have to send the complete device, that is, the high-voltage unit, operating unit and also the pertaining cables, to have it repaired.

#### 5.1.2 Manufacturer's service

It's recommended after expiration of a service interval of 200 operating hours or after 24 months, the device should be sent to the service department to have a checkup.

Send the complete tester , i.e., the high-voltage unit, operating unit and the pertaining cables.

Within the framework of manufacturer's service, the following activities are performed:

- technical inspection,
- updating of software, if necessary,
- complete functional test,
- calibration of device.

## 5.2 Important transport directions

The tester should always be handled with great care during transport. Greater mechanical loads such as shocks or dropping to the ground must be strictly avoided!



### WARNING!

The high-voltage device may be transported and stored only in the vertical position. **Non-observance of this requirement may cause leakage of transformer oil from the safety valve!** Moreover, if the position deviates extremely from the vertical position, the **high-voltage winding of the transformer may become irreversibly damaged.**

## 6 Troubleshooting

If the device does not work properly or cannot be put into operation, carry out the following simple checks and mind the hints given before sending the device to the manufacturer.

### Fault: No function, signal lamp „Mains On“ does not illuminate

- Has the device been properly connected to the mains, and is mains voltage existing?
- Is EMERGENCY STOP button released?
- Are fuses properly inserted? Is any fuse defective?

### Fault: Signal lamp „Ground connection“ does not illuminate

- Are test object, high-voltage unit and operating unit properly grounded?
- Is the high-voltage unit properly connected to operating unit? Is the connector locked?
- In case of power supply from inverter or emergency generator set: Has protective ground been connected to the operating unit?

### Fault: Undefined behaviour of control

- To reset the control, switch the unit off with the mains switch **Mains**, and then switch it on again after about 5 seconds.

## 7 Technical specifications

### 7.1 S-24 VLF

#### Power supply

Mains voltage 230 V  $\pm$  10% / 50/60 Hz  
Current input 10 A (nominal) / 15 A (peak)  
Power input max. 3000 VA

#### Output voltage

VLF 5...24 kV<sub>RMS</sub>, similar sinusoidal  
DC  $\pm$ 0...34 kV DC

Maximum load (VLF)	0.1 Hz	0.05 Hz*	0.02 Hz* (option)
18 kV <sub>RMS</sub>	6.8 $\mu$ F	11.0 $\mu$ F	15.0 $\mu$ F
24 kV <sub>RMS</sub>	5.0 $\mu$ F	9.4 $\mu$ F	15.0 $\mu$ F

#### Output current (DC)

Overcurrent tripping  $\pm$ 10 mA

#### Measuring ranges

Voltage -40 ... 0 ... +40 kV  
Current  $\pm$ 100  $\mu$ A / 1 mA / 10 mA

#### Measuring error

Digital measurement  $\pm$ 1%  
Analog meters  $\pm$ 2%

#### Discharge device

Max. discharge capacity 9000 J according to relation  $E = \frac{U^2 \cdot C}{2}$  (i.e. C = 15  $\mu$ F at U = 34 kV)

#### Operating temperature

Storage temperature -20°C ... +45°C

-25°C ... +70°C

#### Weight

Operating device 17 kg  
High-voltage device 38 kg

## 7.2 S-36 VLF

### Power supply

Mains voltage 230 V ± 10% / 50/60 Hz  
 Current input 10 A<sub>(nominal)</sub> / 15 A<sub>(peak)</sub>  
 Power input max. 3000 VA

### Output voltage

VLF 5...36 kV<sub>RMS</sub>, similar sinusoidal  
 DC ±0...52 kV DC

Maximum load (VLF)	0.1 Hz	0.05 Hz*	0.02 Hz* (option)
6 kV <sub>RMS</sub>	8.9 μF	11.5 μF	15.0 μF
18 kV <sub>RMS</sub>	4.9 μF	8.1 μF	15.0 μF
26 kV <sub>RMS</sub>	3.3 μF	4.5 μF	9.9 μF
36 kV <sub>RMS</sub>	2.4 μF	4.1 μF	8.1 μF

### Output current (DC)

Overcurrent tripping ±10 mA

### Measuring ranges

Voltage -60 ... 0 ... +60 kV  
 Current ±100 μA / 1 mA / 10 mA

### Measuring error

Digital measurement ±1%  
 Analog meters ±2%

### Discharge device

Max. discharge capacity 12500 J according to relation  $E = \frac{U^2 \cdot C}{2}$  (i.e. C = 10 μF at U = 50 kV)

### Operating temperature

-20°C ... +45°C

Storage temperature

-25°C ... +70°C

### Weight

Operating device 17 kg

High-voltage device 48 kg

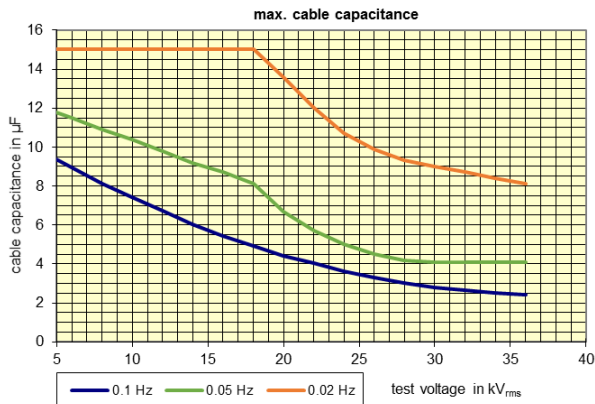

## 7.3 S-44 VLF

### Power supply

Mains voltage 230 V ± 10% / 50/60 Hz  
 Current input 10 A <sub>(nominal)</sub> / 15 A <sub>(peak)</sub>  
 Power input max. 3000 VA

### Output voltage

VLF 5...44 kV<sub>RMS</sub>, similar sinusoidal  
 DC ±0...62 kV DC

Maximum load (VLF)	0.1 Hz	0.05 Hz*	0.02 Hz* (option)
6 kV <sub>RMS</sub>	7.2 μF	11.5 μF	15.0 μF
18 kV <sub>RMS</sub>	4.4 μF	8.1 μF	15.0 μF
26 kV <sub>RMS</sub>	2.7 μF	4.5 μF	9.9 μF
36 kV <sub>RMS</sub>	2.2 μF	4.1 μF	8.1 μF
38 kV <sub>RMS</sub>	1.9 μF	3.8 μF	7.9 μF
44 kV <sub>RMS</sub>	1.5 μF	2.8 μF	6.3 μF

### Output current (DC)

Overcurrent tripping ±10 mA

### Measuring ranges

Voltage -70 ... 0 ... +70 kV  
 Current ±100 μA / 1 mA / 10 mA

### Measuring error

Digital measurement ±1%  
 Analog meters ±2%

### Discharge device

Max. discharge capacity 12500 J according to relation  $E = \frac{U^2 \cdot C}{2}$  (i.e. C = 7 μF at U = 60 kV)

### Operating temperature

-20°C ... +45°C

Storage temperature -25°C ... +70°C

### Weight

Operating device 17 kg  
 High-voltage device 49 kg

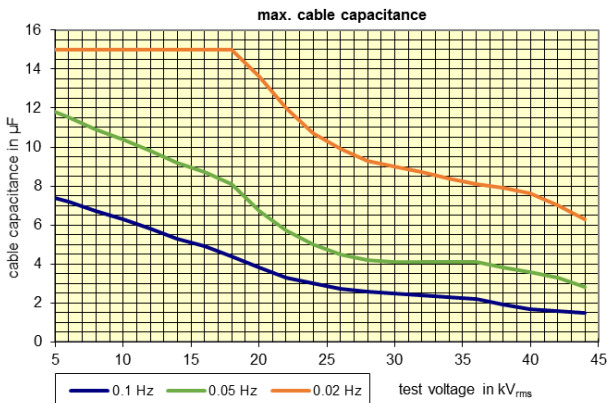



## 7.4 S-57 VLF

### Power supply

Mains voltage 230 V ± 10% / 50/60 Hz  
 Current input 10 A <sub>(nominal)</sub> / 16 A <sub>(peak)</sub>  
 Power input max. 3000 VA

### Output voltage

VLF 5...57 kV<sub>RMS</sub>, similar sinusoidal  
 DC ±0...62 kV DC

Maximum load (VLF)	0.1 Hz	0.05 Hz*	0.02 Hz* (option)
6 kV <sub>RMS</sub>	7.2 μF	11.5 μF	15.0 μF
18 kV <sub>RMS</sub>	4.4 μF	8.1 μF	15.0 μF
26 kV <sub>RMS</sub>	2.7 μF	4.5 μF	9.9 μF
36 kV <sub>RMS</sub>	2.2 μF	4.1 μF	8.1 μF
44 kV <sub>RMS</sub>	1.6 μF	2.8 μF	6.3 μF
54 kV <sub>RMS</sub>	0.9 μF	1.5 μF	2.8 μF
57 kV <sub>RMS</sub>	0.55 μF	0.9 μF	1.3 μF

### Output current (DC)

Overcurrent tripping: ±10 mA

### Measuring ranges

Voltage -70 ... 0 ... +70 kV  
 Current ±100 μA / 1 mA / 10 mA

### Measuring error

Digital measurement ±1%  
 Analog meters ±2%

### Discharge device

Max. discharge capacity 12500 J according to relation  $E = \frac{U^2 \cdot C}{2}$  (i.e. C = 7 μF at U = 60 kV)

### Operating temperature

-20°C ... +45°C

Storage temperature -25°C ... +70°C

### Weight

Operating device 17 kg  
 High-voltage device 49 kg

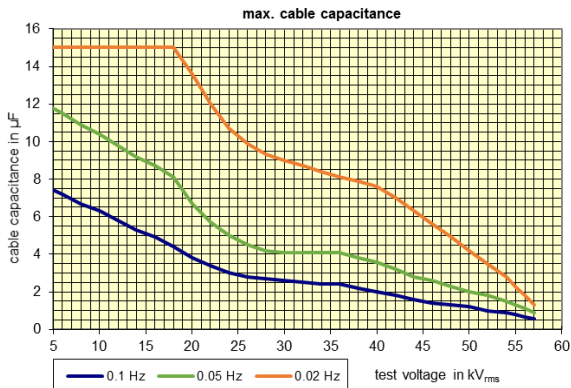

## 8 Accessories

### 8.1 Standard accessories

Standard set of equipment supplied by the manufacturer includes:

- Operating unit
- Protective bag
- High-voltage unit
- High-voltage connecting cable (shielded), standard 5 m
- Connecting cable between operating unit and high-voltage unit (permanently connected to operating unit), standard 3 m
- Mains cable (permanently connected to operating unit), standard 3 m
- Connecting cable between operating unit and protective ground
- Connecting cable between high-voltage unit and station ground
- Service kit
- Transport case – **WAWALVLF**
- Calibration certificate
- User manual

### 8.2 Optional accessories

Additionally, the following items that are not included in the scope of standard equipment may be purchased from the manufacturer or the distributors:

- Data logging (USB) – **WAADAHVVLFDL**
- Frequency extension 0.05 Hz + 0.02 Hz – **WAADAHVVLFFE**
- Transport case with wheels – **WAWALVLF2**

## 9 Manufacturer

The manufacturer of the device and provider of guarantee and post-guarantee service:

**SONEL S.A.**  
Wokulskiego 11  
58-100 Świdnica  
Poland  
tel. +48 74 884 10 53 (Customer Service)  
e-mail: [customerservice@sonel.com](mailto:customerservice@sonel.com)  
web page: [www.sonel.com](http://www.sonel.com)



#### NOTE!

Service repairs must be performed only by the manufacturer.





**SONEL S.A.**

Wokulskiego 11  
58-100 Świdnica  
Poland

**Customer Service**

tel. +48 74 884 10 53  
e-mail: [customerservice@sonel.com](mailto:customerservice@sonel.com)

[www.sonel.com](http://www.sonel.com)