



VEGETABLE PREPARATION MACHINE CA-401

Commercial vegetable preparation machine with an hourly output of up to 650 Kg.



FEATURES AND BENEFITS

- ✓ Stainless steel construction and high quality materials, all suitable for contact with food.
- ✓ New production technology that gives a uniform, high-quality cutting result.
- ✓ Ergonomic design: product is sliced/cut/shredded in one single movement.
- ✓ Large production head with lateral blade, which distributes the product inside the inlet, and handles entire products such as cabbage.
- ✓ The core drill (included) can also be used to achieve the same purpose.
- ✓ High positioned ejection disc allowing to eject a bigger product quantity.
- ✓ The large range of high quality discs and grids allows the operator to obtain over 70 different styles of product.
- ✓ This directs the product avoiding splashing.
- ✓ Electronic, user-friendly control board.
- ✓ Easily removable lever and lid for cleaning purpose.
- ✓ NSF-International certified appliance (complying with Hygiene, Cleaning and Food Material regulations).
- ✓ Please note: as a result of continuous product improvements, these specifications are subject to change without prior notice.



SALES DESCRIPTION

1 speed motor block and a large production attachment.

INCLUDES

- ✓ 1 speed motor block.
- ✓ Core drill (optional use).
- ✓ Large capacity hopper.

DYNAMIC PREPARATION
COMMERCIAL VEGETABLE PREPARATION MACHINES



sammic | www.sammic.com
Food Service Equipment Manufacturer

Polígono Basarte, 1. phone +34 943 15 72 36
20720 Azkoitia, Spain sales@sammic.com



Project	Date
Item	Qty
Approved	

product sheet
updated 24/04/2018



VEGETABLE PREPARATION MACHINE CA-401

Commercial vegetable preparation machine with an hourly output of up to 650 Kg.



SPECIFICATIONS

Hourly production: 200 Kg - 650 Kg

Inlet opening: 286 cm²

Disc diameter: 205 mm

Motor speed: 365 rpm

Total loading: 550 W

External dimensions (WxDxH)

Width: 389 mm

Depth: 382 mm

Height: 646 mm

Net weight: 24 Kg

Noise level (1m.): <70 dB(A)

Background noise: 32 dB(A)

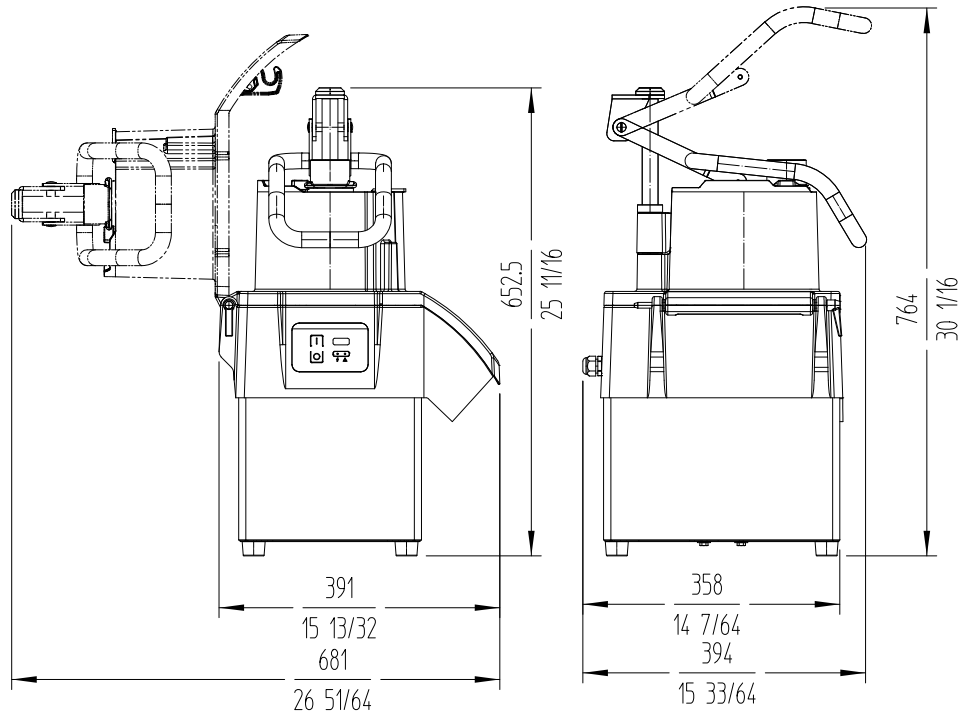

AVAILABLE MODELS

1050315 Vegetable preparation machine CA-401 230-400/50/3N

1050059 Vegetable preparation machine CA-401 230/50/1

* Ask for special versions availability

ACCESSORIES

- FC Slicing Disc
- FCC Curved Slicing Discs
- FCO Rippled Slicing Discs
- FFC Chipping Grids
- FMC Dicing Grids
- FCE Julienne Discs
- FR Shredding & Grating Discs
- Long vegetable attachment
- Universal hopper
- Disc and Grid Holder Device
- Automatic Hopper
- Grid Cleaning Kit

DYNAMIC PREPARATION
COMMERCIAL VEGETABLE PREPARATION MACHINES

sammic | www.sammic.com
Food Service Equipment Manufacturer

Polígono Basarte, 1. phone +34 943 15 72 36
20720 Azkoitia, Spain sales@sammic.com



Project	Date
Item	Qty
Approved	

product sheet
updated 24/04/2018