



VEGETABLE PREPARATION MACHINE CA-301 VV (VARIABLE SPEED)

Commercial vegetable preparation machine with an hourly output of up to 450 Kg.



FEATURES AND BENEFITS

- ✓ Stainless steel construction and highest quality material, all suitable for contact with food.
- ✓ New production technology that gives a uniform, highest-quality cutting result.
- ✓ Ergonomic design: product is sliced/cut/shredded in one single movement.
- ✓ The large range of high quality discs and grids allows the operator to obtain over 70 different styles of product.
- ✓ Lateral product ejection, which allows the appliance to be placed in a less deep working surface.
- ✓ This directs the product avoiding splashing.
- ✓ Electronic, user-friendly control board with 5 speeds.
- ✓ Easily removable lever and lid for cleaning purposes.
- ✓ NSF-International certified appliance (complying with Hygiene, Cleaning and Food Material regulations).

INCLUDES

- ✓ Adjustable speed motor block.
- ✓ Regular hopper.

SALES DESCRIPTION

Variable speed motor block and a universal attachment.

DYNAMIC PREPARATION
COMMERCIAL VEGETABLE PREPARATION MACHINES



sammic | www.sammic.com
Food Service Equipment Manufacturer

Polígono Basarte, 1. phone +34 943 15 72 36
20720 Azkoitia, Spain sales@sammic.com



Project	Date
Item	Qty
Approved	

product sheet
updated 24/04/2018



VEGETABLE PREPARATION MACHINE CA-301 VV (VARIABLE SPEED)

Commercial vegetable preparation machine with an hourly output of up to 450 Kg.



SPECIFICATIONS

Hourly production: 150 Kg - 500 Kg
 Inlet opening: 136 cm²
 Disc diameter: 205 mm
 Speeds as veg. slicer (positions): 5 (365 rpm - 1000 rpm)
 Total loading: 1500 W

External dimensions (WxDxH)

Width: 391 mm
 Depth: 409 mm
 Height: 567 mm
 Net weight: 28 Kg
 Noise level (1m.): <70 dB(A)
 Background noise: 32 dB(A)

Crated dimensions

435 x 430 x 600 mm
 Gross weight: 25.1 Kg.

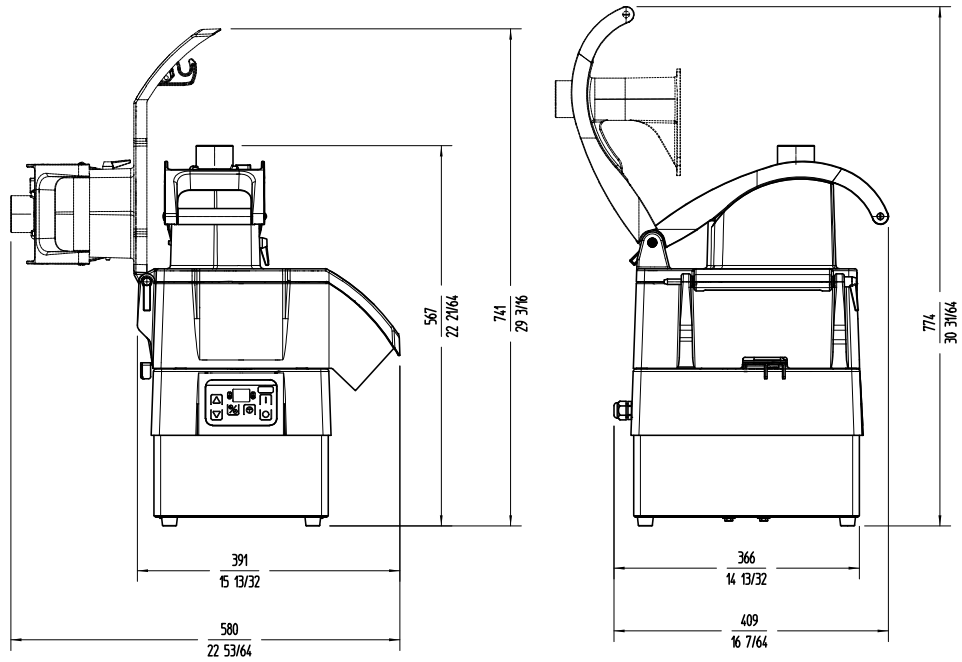

AVAILABLE MODELS

1050355 Vegetable preparation machine CA-301VV 230/50-60/1 (variable speed)

* Ask for special versions availability

ACCESSORIES

- FC Slicing Disc
- FCC Curved Slicing Discs
- FCO Rippled Slicing Discs
- FFC Chipping Grids
- FMC Dicing Grids
- FCE Julienne Discs
- FR Shredding & Grating Discs
- Long vegetable attachment
- Universal hopper
- Disc and Grid Holder Device
- Grid Cleaning Kit

DYNAMIC PREPARATION
COMMERCIAL VEGETABLE PREPARATION MACHINES

sammic | www.sammic.com
 Food Service Equipment Manufacturer

Polígono Basarte, 1. phone +34 943 15 72 36
 20720 Azkoitia, Spain sales@sammic.com



Project	Date
Item	Qty
Approved	

product sheet
updated 24/04/2018