



# VACUUM SEALER SE-520

Tabletop model. 20m³/h. 420+420 mm.



FOOD PRESERVATION AND SOUS-VIDE  
VACUUM PACKING MACHINES - "SENSOR" LINE



## FEATURES AND BENEFITS

- ✓ Powered by Busch.
- ✓ Vacuum controlled by sensor.
- ✓ Vacuum PLUS.
- ✓ Digital keyboard.
- ✓ Control panel equipped with display indicating the exact vacuum percentage.
- ✓ "Pause" button to marinate food.
- ✓ Safe liquid packing thanks to sensor control.
- ✓ Double seal.
- ✓ Cordless sealing bar.
- ✓ Bag-sealing programme.
- ✓ Pulse-controlled decompression.
- ✓ Vac-Norm ready with Automatic decompression.
- ✓ Stainless steel body and chamber. Long-shaped chamber.
- ✓ Damped transparent lid of highly durable polycarbonate.
- ✓ Dry-oil programme for drying the pump.
- ✓ Working hours counter for oil changes.
- ✓ Safety system with protection against vacuum failure.

## SALES DESCRIPTION

Two sealing bars (420+420 mm.)  
 20 m³/h Busch vacuum pump.  
 Vacuum controlled by sensor.

## INCLUDES

- ✓ Sensor Controls
- ✓ Up to 10 seconds of extra vacuum pull
- ✓ Soft air function
- ✓ Dry oil cycle
- ✓ BUSCH pump
- ✓ NSF Approved
- ✓ Clear methacrylate lid
- ✓ Filling plate



**sammic** | [www.sammic.com](http://www.sammic.com)  
**Food Service Equipment Manufacturer**

Polígono Basarte, 1. phone +34 943 15 72 36  
 20720 Azkoitia, Spain [sales@sammic.com](mailto:sales@sammic.com)



Project	Date
Item	Qty
Approved	

product sheet  
 updated 24/04/2018



# VACUUM SEALER SE-520

Tabletop model. 20m<sup>3</sup>/h. 420+420 mm.



## SPECIFICATIONS

Pump capacity: 20 m<sup>3</sup>/h  
 Bar length: 420 mm  
 Total loading: 750 W  
 Vacuum pressure (maximum): 2 mbar

### Internal dimensions

- ✓ Width: 560 mm
- ✓ Depth: 430 mm
- ✓ Height: 183 mm

### External dimensions (WxDxH)

- ✓ Width: 625 mm
  - ✓ Depth: 537 mm
  - ✓ Height: 513 mm
- Net weight: 80 Kg  
 Noise level (1m.): 75 dB(A)  
 Background noise: 32 dB(A)

### Crated dimensions

600 x 750 x 680 mm  
 Gross weight: 84 Kg.

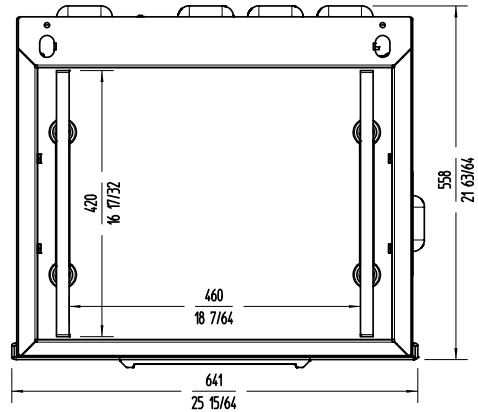
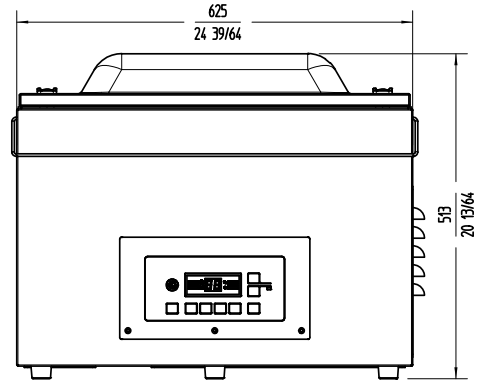
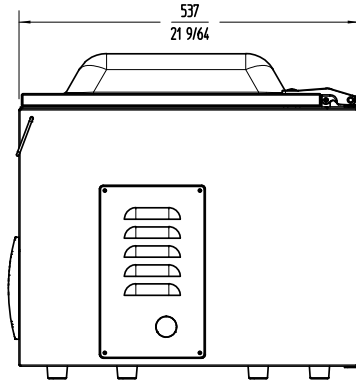

## AVAILABLE MODELS

1140642 Vacuum packing machine SE-520 230/50-60/1

\* Ask for special versions availability

## ACCESSORIES

- Bag cutting kits
- Vac-norm containers
- Filling plates
- Smooth bags for vacuum packing
- Liquid insert plates
- Trolley for vacuum packing machines
- Vac-norm external vacuum kits

FOOD PRESERVATION AND SOUS-VIDE  
VACUUM PACKING MACHINES - "SENSOR" LINE

**sammic** | www.sammic.com  
 Food Service Equipment Manufacturer

Polígono Basarte, 1. phone +34 943 15 72 36  
 20720 Azkoitia, Spain sales@sammic.com



Project	Date
Item	Qty
Approved	

product sheet  
updated 24/04/2018