



# VACUUM SEALER SU-810CC

Floorstanding unit. 100m<sup>3</sup>/h. 581+581 mm.



## FEATURES AND BENEFITS

- ✓ Powered by Busch.
- ✓ Vacuum controlled by sensor.
- ✓ Vacuum PLUS.
- ✓ LCD colour screen: all information at a glance.
- ✓ Backlit touch keyboard.
- ✓ Programmable: 25-programme memory. Blocking option.
- ✓ "Pause" button.
- ✓ Phased vacuum programme.
- ✓ Detection of the evaporation of liquids.
- ✓ Double seal.
- ✓ Cordless sealing bar.
- ✓ Progressive decompression.
- ✓ Vac-Norm ready with Automatic decompression.
- ✓ Stainless steel body and chamber.
- ✓ Damped transparent lid of high durability polycarbonate.
- ✓ Dry-oil programme for drying the pump.
- ✓ Working hours counter for oil changes.
- ✓ Safety system with protection against vacuum failure.
- ✓ NSF-listed.

## SALES DESCRIPTION

Two sealing bars (581+581 mm.)  
 100 m<sup>3</sup>/h Busch vacuum pump.  
 Vacuum controlled by sensor.

## INCLUDES

- ✓ BUSCH pump.
- ✓ Sensor Controls.
- ✓ 25 programmable settings.
- ✓ Vacuum PLUS: up to 10 seconds of extra vacuum pull.
- ✓ Soft air function.
- ✓ Clear methacrylate lid.
- ✓ "PAUSE" function.
- ✓ Liquid detection system.
- ✓ Dry oil cycle.
- ✓ NSF Approved.
- ✓ Filling plate.

## ACCESSORIES

- Bag cutting kits
- Filling plates
- Liquid insert plates
- Vac-norm external vacuum kits
- Vac-norm containers
- Smooth bags for vacuum packing
- CG2 Desktop printer for SU vacuum packing machines \*
- Thermal labels for CG2 printer

**sammic** | [www.sammic.com](http://www.sammic.com)  
**Food Service Equipment Manufacturer**

Polígono Basarte, 1. phone +34 943 15 72 36  
 20720 Azkoitia, Spain [sales@sammic.com](mailto:sales@sammic.com)



Project	Date
Item	Qty
Approved	

FOOD PRESERVATION AND SOUS-VIDE  
 VACUUM PACKING MACHINES - "SENSOR ULTRA" LINE

product sheet  
 updated 01/08/2018



# VACUUM SEALER SU-810CC

Floorstanding unit. 100m<sup>3</sup>/h. 581+581 mm.



## SPECIFICATIONS

Pump capacity: 100 m<sup>3</sup>/h  
 Bar length: 581 mm + 581 mm  
 Total loading: 2200 W  
 Vacuum pressure (maximum): 0,5 mbar

### Internal dimensions

- ✓ Width: 864 mm
- ✓ Depth: 603 mm
- ✓ Height: 215 mm

### External dimensions (WxDxH)

- ✓ Width: 960 mm
  - ✓ Depth: 757 mm
  - ✓ Height: 998 mm
- Net weight: 250 Kg  
 Noise level (1m.): 75 dB(A)  
 Background noise: 32 dB(A)

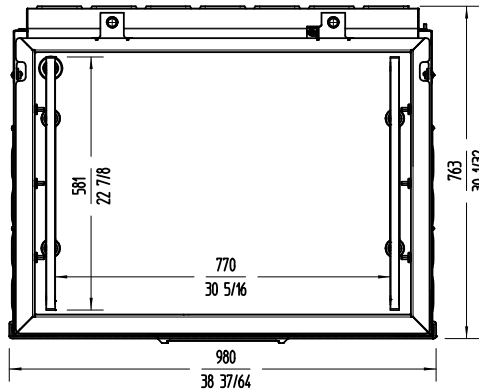
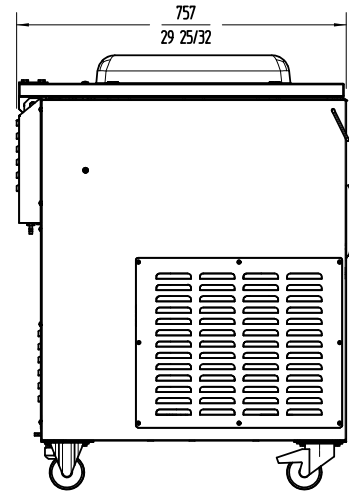
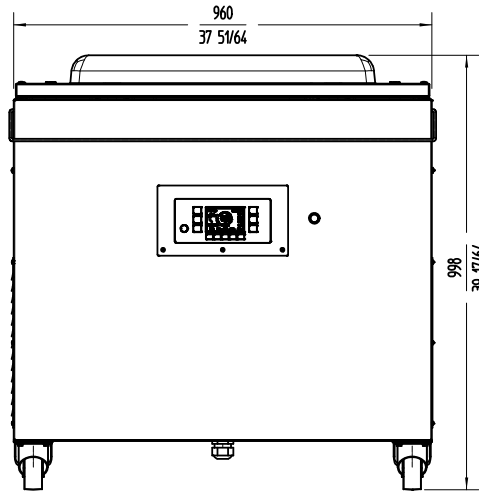

## AVAILABLE MODELS

1140945 Vacuum packing machine SU-810 CC 230-400/50/3N

\* Ask for special versions availability

**sammic** | [www.sammic.com](http://www.sammic.com)  
**Food Service Equipment Manufacturer**

Polígono Basarte, 1. phone +34 943 15 72 36  
 20720 Azkoitia, Spain sales@sammic.com



Project	Date
Item	Qty
Approved	

FOOD PRESERVATION AND SOUS-VIDE  
 VACUUM PACKING MACHINES - "SENSOR ULTRA" LINE

product sheet  
 updated 01/08/2018