

Workholding

Contents

New Products – Spring 2022	3
All from one source	4
Makro-Grip® Stamping Technology	6
Makro-Grip® 5-Axis Vises	24
Makro-Grip® Ultra	58
Conventional Workholding	84
Terms & Conditions, Imprint	120

New Products Spring 2022

Compared to the last version of our catalog, the following products have been added to our workholding range:

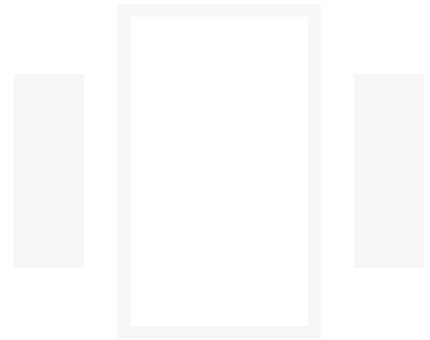

Makro-Grip® Ultra Base Plates

You want your clamping system to be permanently mounted on the machine table? If it is not absolutely necessary to remove the Makro-Grip® Ultra clamping system from the machine table and thus use a zero-point clamping system, Makro-Grip® Ultra can also be used in combination with the new base plates, which are screwed to the clamping system and firmly mounted on the machine table. By fixing them in the grooves of the machine table, the base plates can be flexibly moved in x-direction, allowing the distance to a neighboring clamping unit to be reduced or increased.

Learn more on page 70



Vasto-Clamp Base-, Gripping and Top Jaws for I.D. clamping

As opposed to the common clamping method, we now also offer the clamping jaws for the Vasto-Clamp 6-jaw chuck as a version for inner diameter clamping. Special base jaws and 4 different types of clamping jaws are available for this purpose.

Learn more on page 92 / 93



What else is new?

For the two jaw types Makro-4Grip and Makro-Grip® contour jaws, additional tables are now listed, which provide information on the respective clamping ranges for the different vise base body lengths.

Learn more on pages 42, 43 and 50, 51

There is a technical change in the Makro-Grip® center jaws with serration (item no. 81483-TG and 81485-TG). The center jaw has been widened at the top, in order to increase the clearance between the workpieces in case of multiple clamping.

Learn more on page 73

Workholding and Automation – from one source

A proven and perfectly combined package of workholding, zero-point clamping and automation, along with our unrivaled stamping technology, provides our customers with the necessary requirements to stay efficient and competitive.





Zero-Point Clamping

Quick-Point® fits anywhere

- Fits any machine table
- Versatile application possibilities for 3-/5-axis machines and rotary tables
- Modular design
- Enormous set-up time savings
- Wide range of customization options
- Highly precise positioning
- Direct clamping of workpieces
- Simple operation, easy maintenance and cleaning



Workholding

A suitable clamping solution for any machining task

- For raw, round, pre-machined, (semi-) finished and large parts
- Highest holding forces and process reliability
- Ideal accessibility for 5-sided machining
- Wear and distortion-free clamping
- Fully compatible centering vises and clamping jaws
- Compact design, low weights, ergonomic handling
- Integrated zero-point adaptation
- For automated or manual production, can be used with competing systems



Automation

Flexible single part or large scale production

- Retrofittable to any machining center
- (Re-)equipping of automation system within a few seconds
- Highly flexible single-part or batch production
- Simple operation, no knowledge about robots required
- Quick installation, minimum training expenses
- No skilled labor required
- Automation trolleys as a flexible storage
- High storage capacity on small footprint



**MAKRO·GRIP®
STAMPING
TECHNOLOGY**



- 9 Makro·Grip® **Stamping Technology**
- 16 Stamping Unit for workbenches
- 17 Stamping Unit on trolley
- 20 Center Marking Tool and Gauging Blocks
- 21 Stamping Jaws
- 22 Makro·4Grip **Round Part Clamping**

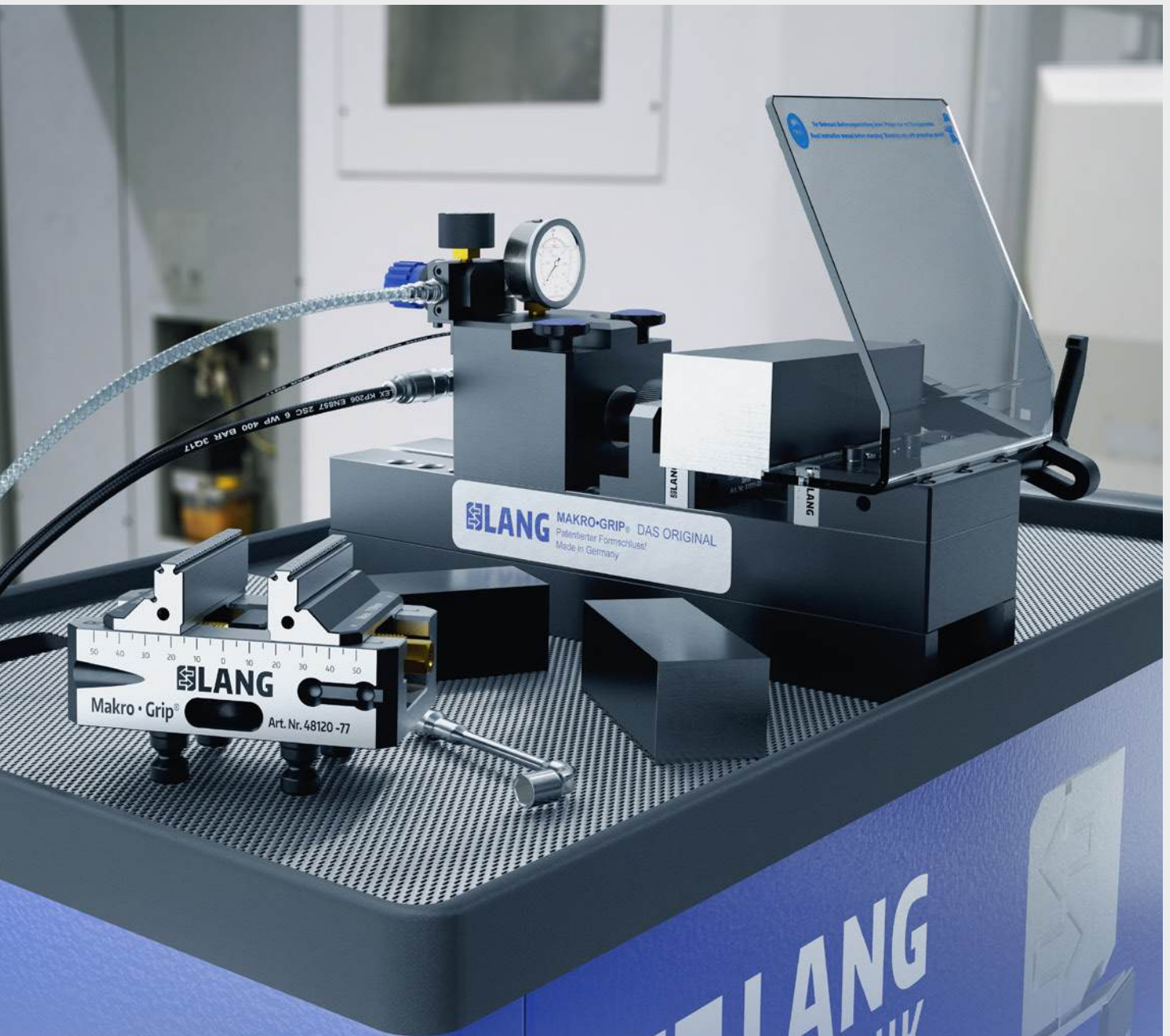

**simple.
reliable.
gripping.**

„The Original“ – Stamping Technology

The Makro·Grip® Stamping Technology allows for:

SECURE AND RELIABLE CLAMPING PROCESSES

WEAR- AND DISTORTION-FREE CLAMPING

ENORMOUS MATERIAL SAVINGS

The stamping technology that has become popular was invented by LANG and can be regarded as the heart of the Makro·Grip® workholding system. It guarantees highest holding forces and ideal accessibility in 5-axis machining of blanks. The pre-stamping of workpiece blanks favors a variety of factors that have a positive effect on process reliability and cost-efficient production, which is why the Makro·Grip® technology is considered the benchmark in today's workholding. During the pre-stamping process workpieces are prepared with a defined contour at an external stamping unit under high pressure, which generates a form-fit between serrated jaws of the Makro·Grip® 5-Axis Vise and the stamping contour on the workpiece. As pre-stamping is conducted externally, no additional machine capacities have to be spent in order to prepare the workpiece. The process only takes about 5 seconds – but these 5 seconds will forever change your manufacturing processes and the way you clamp your workpieces.

Benefits of the Makro·Grip® Stamping Technology:



Highest holding forces
due to form-fit clamping



Maximum
process reliability



Increased
milling quality



Minimum wear on
the clamping device



Effortless pre-stamping
of high-tensile material



High repeatability
thanks to defined
stamping contour

Different types of Stamping Units

Stamping Units are available in a stationary version for workbenches as well as mobile on a trolley. The actual stamping unit is available in two different lengths with either Standard Stamping Jaws for materials up to 35 HRC or with High-End Stamping Jaws for materials up to 45 HRC.

The Dual Stamping Unit is suitable for extremely long workpieces. The mobile Stamping Unit offers great flexibility, allowing workpieces to be pre-stamped wherever they are needed. Pre-stamping is conducted conveniently via foot pedal, so both hands remain free to hold and insert heavy workpieces.



Makro-Grip® Stamping Unit for workbenches



Trolley with Makro-Grip® Stamping Unit



Trolley with Makro-Grip® Stamping Unit, extended version, on T-slot plate



Trolley with Makro-Grip® Dual Stamping Unit, extended version, on T-slot plate



Makro-4Grip Stamping Technology for round parts

With the Makro-4Grip clamping system there are completely new possibilities and applications for the stamping technology. By retrofitting the Makro-Grip® stamping unit and a LANG centering vise the form-fit clamping principle can be applied for round parts now easily and cost-efficiently. Makro-4Grip jaws are available for all LANG vise sizes and cover a clamping range of Ø 36 to Ø 300 depending on their type and the vise's base length.

Makro-Grip® Ultra Stamping Technology for flat and large components

The Stamping Technology is also available for large parts. The form-fit effect which is made possible by pre-stamping guarantees highest holding forces at low tightening torque. Especially with large or deformation-sensitive components, holding forces and process reliability are without question among the most important attributes when clamping large components – two factors that are clearly associated with the Stamping Technology. Pre-stamped plate material on the other hand can be held extremely gently, but yet securely. The low actuation torque virtually eliminates distortion and deformation on the material.



Functional principle of the Stamping Technology

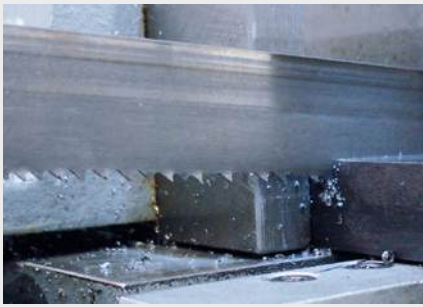

1 – Sawing

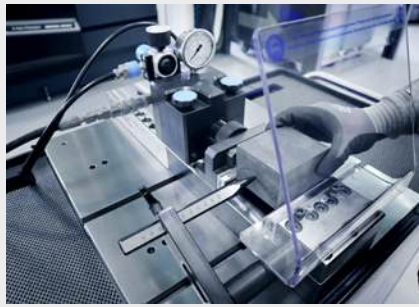

2 – Stamping

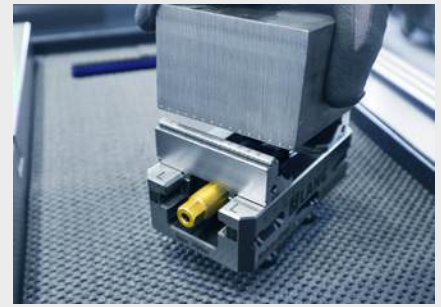

3 – Clamping

5 seconds that revolutionize your machining processes!

The workpiece is stamped directly on the saw cut or cinder layer of the blank. Additional preparatory work is generally not necessary. Stamping is realized within less than 5 seconds. The form-fit

effect between the stamping contour in the workpiece (truncated pyramid indents) and the holding teeth of the 5-Axis Vise allows for an accurate repeatability even without endstops.

A reliable wear-free clamping process for high-tensile materials

The stamping unit adds the form-fit contour to the workpiece with up to 20 tons of pressure. This allows you to clamp even high-tensile materials up to 1.500 N/mm² tensile strength reliably and virtually wear-free. Different material hardness requires different

stamping jaws to extend longevity and guarantee safe clamping. Our standard jaws allow you to stamp workpieces up to 35 HRC, whereas high-tensile materials up to 45 HRC require High-End stamping jaws.

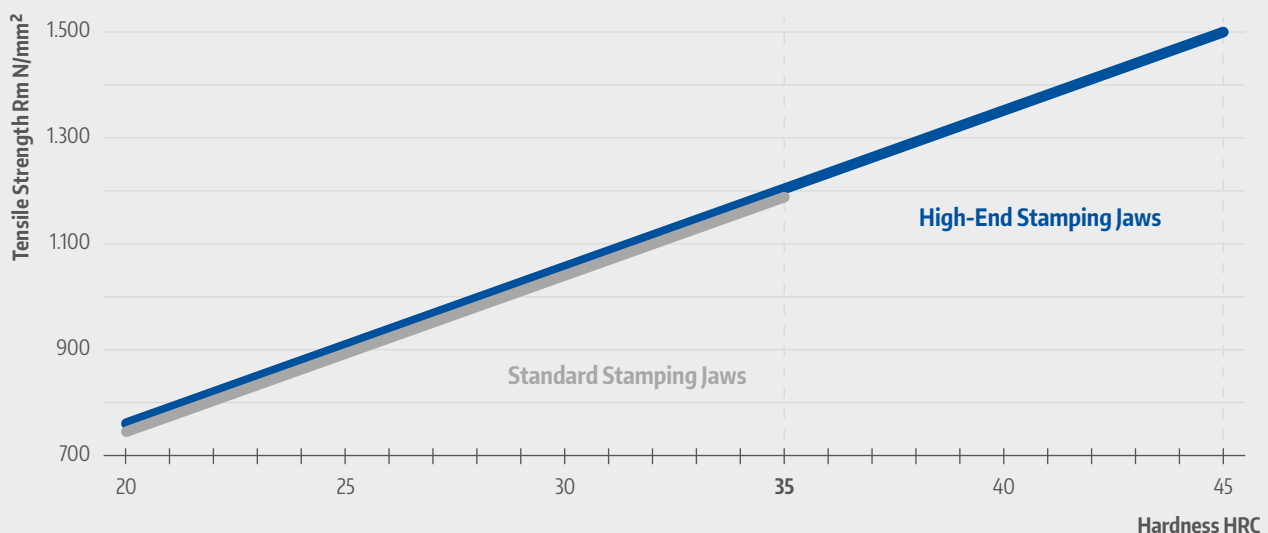

Setting the stamping depth and pressure correctly

The large number of alloys makes it difficult to make an exact statement about the stamping pressure to be set. The two main parameters are workpiece width and material. In general, we recommend always starting with a low stamping pressure and slowly increasing it until the desired stamping depth in the workpiece is achieved.

For the material type 1.7131 (16MnCr5) we have made a measurement in this regard and set rough guide values for setting the stamping pressure.

Material type 1.7131 (16MnCr5)

MATERIAL WIDTH	STAMPING PRESSURE
76 mm	100 bar
126 mm	140 bar

Please note: Depending on the surface quality, the required inlet pressure may deviate from these values. Therefore, carry out a test stamping and check the stamping contour with a visual inspection before each stamping series.

Stamping tooth imprint with correct stamping

The visual inspection gives the user reliable feedback as to whether the inlet pressure has been selected correctly or whether readjustment is required. Depending on the material hardness, there are two different stamping tooth imprints. Soft material needs a bit

more “holding surface” due to the higher toughness. Therefore, it must be stamped in such a way that control marks between the stamping tooth imprints are visible. With harder materials, it is not necessary to stamp as deeply because of the higher resistance.

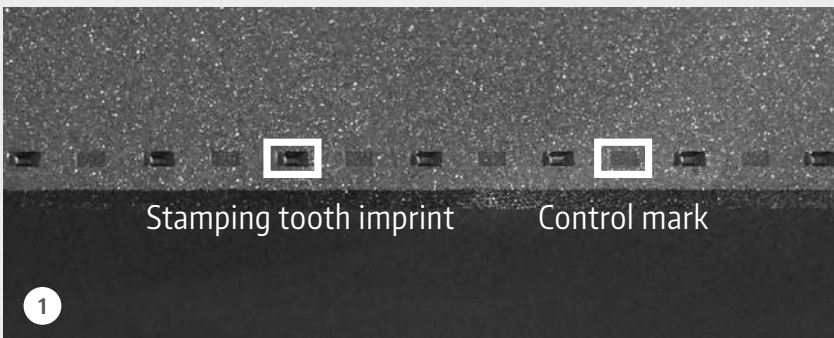

1 Material < 35 HRC with Standard Stamping Jaws

The stamping contour with alternating stamping tooth imprints and control marks is clearly visible. The depth of the control marks should be about 0.1 mm. The depth of the imprints should be about 0.25 mm.

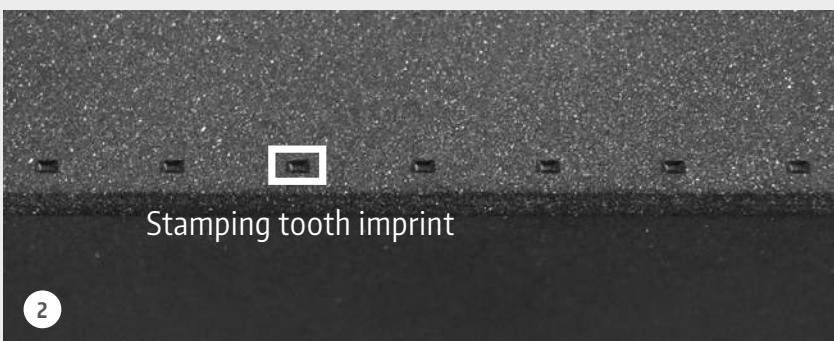

2 Materials > 35 HRC with High-End Stamping Jaws

For material with a hardness between 35 and 45 HRC, the control marks should not be visible. The depth of the imprints is about 0.15 mm.

Highest holding forces and process reliability thanks to clamping by form-fit

Conventional vises penetrate the workpiece blank with high forces exposing both, the vise and the workpiece to high strains. The Makro-Grip® technology however uses a different approach. By pre-stamping the workpiece blank with up to 20 tons of pressure and preparing it with a defined contour, the forces are already applied before the actual clamping process. Once it is prepared with the contour (pyramid-shaped truncated indents), the Makro-Grip® 5-Axis Vise can hold the workpiece by

form-fit, absolutely gently and securely with low clamping pressure – always with the same clamping jaws, regardless of the material and the hardness. Due to the low clamping pressure, distortion on the workpiece as well as wear on the vise can virtually be ruled out. Even with high-tensile material an always consistent clamping quality is guaranteed, which is crucial to achieving the desired quality of the machined workpiece.

The benefits of the stamping technology:

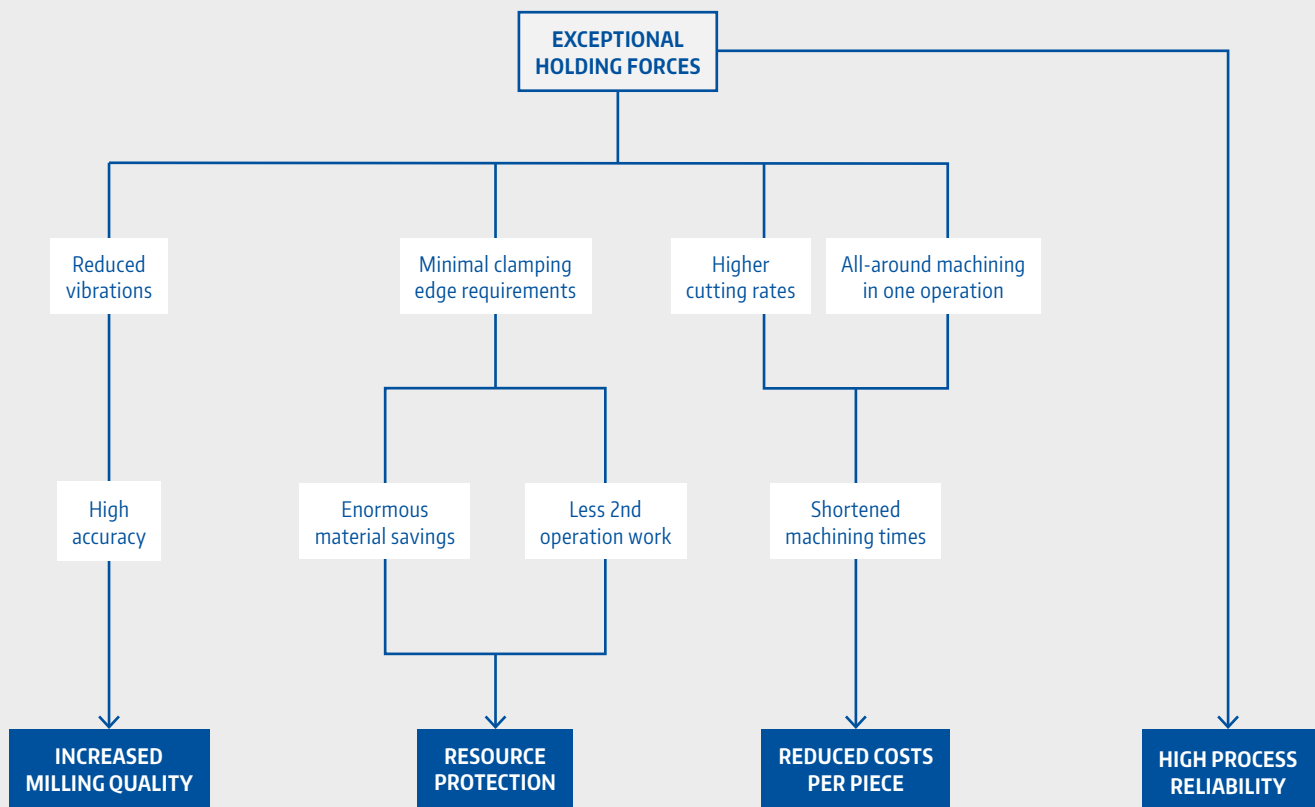

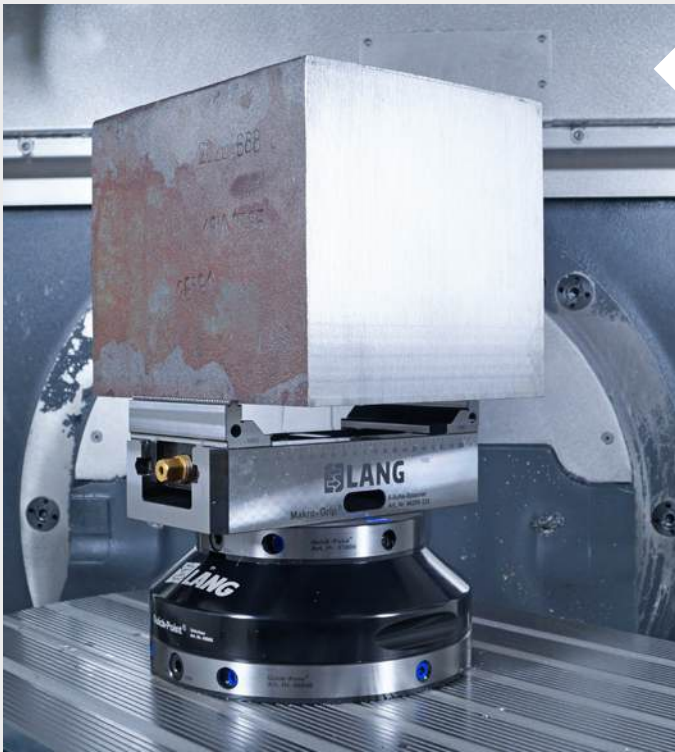

Clamping large workpieces with compact vises

Stamping Technology allows the Makro-Grip® 5-Axis Vise to clamp workpieces which substantially exceed its volume. Despite a clamping depth of only 3 mm the Makro-Grip® Stamping Technology guarantees highest process reliability. The compact design in relation to the maximum allowed workpiece size ensures ideal accessibility and thus allows for short tools which results in reduced vibrations and higher cutting rates.

As a guideline, the Makro-Grip® 5-Axis Vise is able to clamp parts of following size:

Width of workpiece:
3 × jaw width of vise
 Height of workpiece:
2 × jaw width of vise

"One and done" - finishing parts in one operation

The form-fit between clamping jaw serration and stamping contour makes it possible to safely pick up the workpiece at its smallest cross-section and clamp it edgewise with ideal accessibility. This strategy allows a lot of parts to be finished in one operation. For automated, lights-out machining it means that complete batches can be produced without the presence of an operator.



Makro-Grip® Stamping Unit

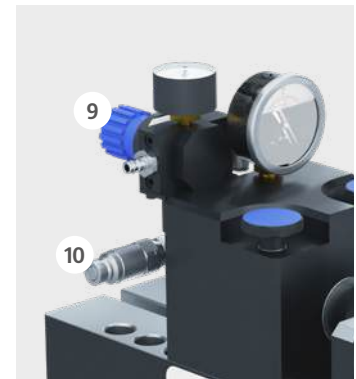

Side view

- 1 Operated pneumatically by hand or foot
- 2 Pneumatic-hydraulic power multiplier with visible oil-level display
- 3 Makrolon protection shield
- 4 Easily readable hydraulic pressure gauge
- 5 Quick adjustment of stamping width for different part sizes
- 6 Robust steel hydraulic housing with integrated T-slot key
- 7 Scaled endstop for quick positioning of blanks
- 8 Stamping jaws for all materials up to 35 HRC / 45 HRC
- 9 Convenient adjustment of the stamping pressure
- 10 Quick connection system consisting of quick connector and quick connector socket

MAKRO-GRIP® STAMPING UNIT FOR WORKBENCHES

ITEM NO.	TYPE	MAX. STAMPING RANGE	TYPE OF STAMPING JAWS	WEIGHT
41200	Standard	245 mm	Standard stamping jaws for materials up to 35 HRC	72 kg
41350	Extended	355 mm	Standard stamping jaws for materials up to 35 HRC	77 kg
41200-HE	Standard	245 mm	High-End stamping jaws for materials up to 45 HRC	72 kg
41350-HE	Extended	355 mm	High-End stamping jaws for materials up to 45 HRC	77 kg

- Scope of delivery:
- Stamping vise
 - Stamping jaws with parallels, 3 mm
 - Pneumatic-hydraulic power multiplier (1 – 360 bar)
 - Gauging blocks for measuring wear of stamping teeth
 - Scaled workpiece endstop
 - Protection shield

Stamping trolley with Makro·Grip® Stamping Unit, Standard



- 1 Makro·Grip® Standard Stamping Unit with a stamping range up to 245 mm
- 2 T-slot plate can be retrofitted
- 3 Practical, rigid trolley for a flexible and mobile use
- 4 Broad space on the plastic tray that can be used for preparing vises or for depositing tools, etc.

STAMPING TROLLEY WITH MAKRO·GRIP® STAMPING UNIT, STANDARD

ITEM NO.	TYPE	MAX. STAMPING RANGE	TYPE OF STAMPING JAWS	WEIGHT
41521	Standard	245 mm	Standard stamping jaws for material up to 35 HRC	215 kg
41521-HE	Standard	245 mm	High-End stamping jaws for material up to 45 HRC	215 kg

- Scope of delivery:
- Stamping vise
 - Stamping jaws with parallels, 3 mm
 - Workshop trolley
 - Protection shield
 - Pneumatic-hydraulic power multiplier (1 - 360 bar)
 - Gauging blocks for measuring wear of stamping teeth
 - Scaled workpiece endstop

Stamping trolley with Makro-Grip® Stamping Unit, extended, on T-slot plate



- 1 Large stamping range up to 355 mm
- 2 Practical, rigid trolley for a flexible and mobile use
- 3 T-slot plate included allowing a second stamping unit to be retrofitted easily with marking bores or T-slot

STAMPING TROLLEY WITH MAKRO-GRIP® STAMPING UNIT, EXTENDED, ON T-SLOT PLATE

ITEM NO.	TYPE	MAX. STAMPING RANGE	TYPE OF STAMPING JAWS	WEIGHT
41400	Extended	355 mm	Standard stamping jaws for material up to 35 HRC	310 kg
41400-HE	Extended	355 mm	High-End stamping jaws for material up to 45 HRC	310 kg
41140	Additional extended stamping vise for dual stamping	355 mm	Standard stamping jaws for material up to 35 HRC	50 kg
41140-HE	Additional extended stamping vise for dual stamping	355 mm	High-End stamping jaws for material up to 45 HRC	50 kg

Scope of delivery Item No. 41400 und 41400-HE:

- Stamping vise
- T-slot plate 596 × 496 mm
- Stamping jaws with parallels, 3mm
- Pneumatic-hydraulic power multiplier (1 - 360 bar)
- Workshop trolley
- Gauging blocks for measuring wear of stamping teeth
- Scaled workpiece endstop
- Protection shield

Stamping trolley with Makro·Grip® Dual Stamping Unit, extended, on T-slot plate



STAMPING TROLLEY WITH MAKRO·GRIP® DUAL STAMPING UNIT, EXTENDED, ON T-SLOT PLATE

ITEM NO.	TYPE	MAX. STAMPING RANGE	TYPE OF STAMPING JAWS	WEIGHT
41402	Extended	2 × 355 mm	Standard stamping jaws for material up to 35 HRC	360 kg
41402-HE	Extended	2 × 355 mm	High-End stamping jaws for material up to 45 HRC	360 kg

Scope of delivery:	<ul style="list-style-type: none"> – 2 stamping vises – T-slot plate 596 × 496 mm – 2 pairs of stamping jaws with parallels, 3 mm – Pneumatic-hydraulic power multiplier (1 - 360 bar) 	<ul style="list-style-type: none"> – Workshop trolley – Gauging blocks for measuring wear of stamping teeth – 2 scaled workpiece endstop – 2 protection shield
--------------------	----------------------------------------------------------------------------------------------------------------------------------------------------------------------------------------------------------------------------------	----------------------------------------------------------------------------------------------------------------------------------------------------------------------------------------------------------



The dual stamping unit is ideal for preparing long parts with two stamping vises simultaneously and clamping these stamped parts accordingly in two 5-Axis Vises on the machine table.

The distance of the two units can be adjusted individually using the T-slots or marking bores, in order to match the distance of Quick·Point® pitch and thus the position of the Makro·Grip® vises' serration.

Center Marking Tool for Stamping Unit

The center marking tool plunges a notch above the stamping contour at the center of the part.
This marking allows the exact and centric positioning of parts in Makro-Grip® 5-Axis Vises without any endstops.



CENTER MARKING TOOL

ITEM NO.	DESCRIPTION
41010	Center marking tool
41010-01	Spare marking stud

The center marking tool will be mounted to the moveable jaw of the stamping unit with two M 6 × 14 screws (included).

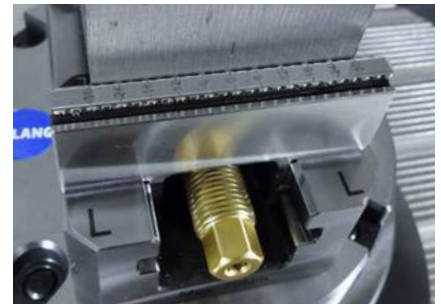

Gauging Blocks for measuring wear of Stamping Jaws



GAUGING BLOCKS FOR MEASURING WEAR OF STAMPING JAWS

ITEM NO.	UNIT
41020	1 set (3 pcs.)

Creating trust! Always the same clamping quality. To ensure consistent holding power in the clamping device, it is necessary to check the wear of the stamping teeth regularly.



Position one gauging block with slots on each side of the stamping jaws. Tighten the jaws by hand only, do not actuate the switch!



Make sure that the stamping teeth are placed in the grooves of the gauging blocks.



When the indicator block fits between the stamping contour, the jaws need to be sent in for reconditioning.

Stamping Jaws

Standard and High-End version



STANDARD STAMPING JAWS WITH 3 MM PARALLELS

ITEM NO.	FOR MATERIALS	UNIT
41111	up to 35 HRC	1 pair

Standard stamping jaws for all materials up to 35 HRC.



HIGH-END STAMPING JAWS WITH 3 MM PARALLELS

ITEM NO.	FOR MATERIALS	UNIT
41112	up to 45 HRC	1 pair

Standard stamping jaws for all materials up to 45 HRC.

Reconditioning Stamping Jaws



RECONDITIONING STAMPING JAWS

ITEM NO.	VERSION
41111-01	Standard stamping jaws
41112-01	High-End stamping jaws

When the stamping teeth are worn out the jaws can be reconditioned up to 6 times per pair. The original thickness of a stamping jaw is 18 mm. With every reconditioning process the thickness is reduced by 0.5 mm until it has reached 15 mm (measured at the highest stamping tooth tip). If a stamping tooth is broken off more than the regular 0.5 mm per reconditioning is required. The total amount of possible reconditioning processes is reduced accordingly.

Note for dual stamping: With every reconditioning process we generally supply shims. The thickness of these shims is determined by the remaining thickness of the stamping jaw. Thickness of stamping jaw and shim will always amount to 18 mm. This guarantees that stamping jaws which have been reconditioned at different intervals can be used together, applying the same pressure on the workpiece.

Tip for your benefit:

In order to bridge the time of the reconditioning process we suggest keeping a second pair of stamping jaws in reserve!



Makro·4Grip Round Part Clamping

PATENT PENDING

Stamping Technology for round parts



Due to its efficiency and the beneficial characteristics for work-holding the LANG stamping technology still is the benchmark when it comes to processing raw parts in 5-axis machining. With the Makro·4Grip Clamping System there are completely new possibilities and applications for the stamping technology. **By retrofitting the Makro·Grip® stamping unit and LANG centering vises the form-fit clamping technology can be applied for round parts now easily and cost efficiently.**

The jaws grip the pre-stamped part in four indentations at a clamping depth of 6.5 mm with up to 20 kN and therefore realize the same form-fit effect as for the well-proven system for prismatic parts. Makro·4Grip covers a clamping range of Ø 36 mm to Ø 300 mm and thus provides a seamless transition from the maximum range of the Preci·Point Collet Chuck.

The Makro·4Grip system consists of universal stamping jaws including stamping inserts for individual positioning as well as matching clamping jaws for all sizes of LANG centering vises. The clamping jaws are available as a separate set of jaws for all 77 and 125 vises.

Stamping imprint

Opposed to stamping prismatic parts where control marks give an indication about the correct stamping depth, the Makro·4Grip technology relies on a visual examination. Stamping round material, the correct imprint is consistently thick and deep.

The required stamping pressure and depth depends on material and its diameter. In general, we recommend always starting with a low stamping pressure and slowly increasing it until the desired stamping depth in the workpiece is achieved.



Makro·4Grip Stamping Technology – The right setup

According to the vise and clamping jaw size used in the machining process, the four stamping inserts (2 inserts per stamping jaw) are placed differently in the respective seats. The scheme below shows how the stamping inserts need to be

positioned for each clamping setup. Makro-4Grip clamping jaws and their clamping ranges can be found with the spare jaws of the Makro-Grip® 5-Axis Vise on pages 42 and 50.

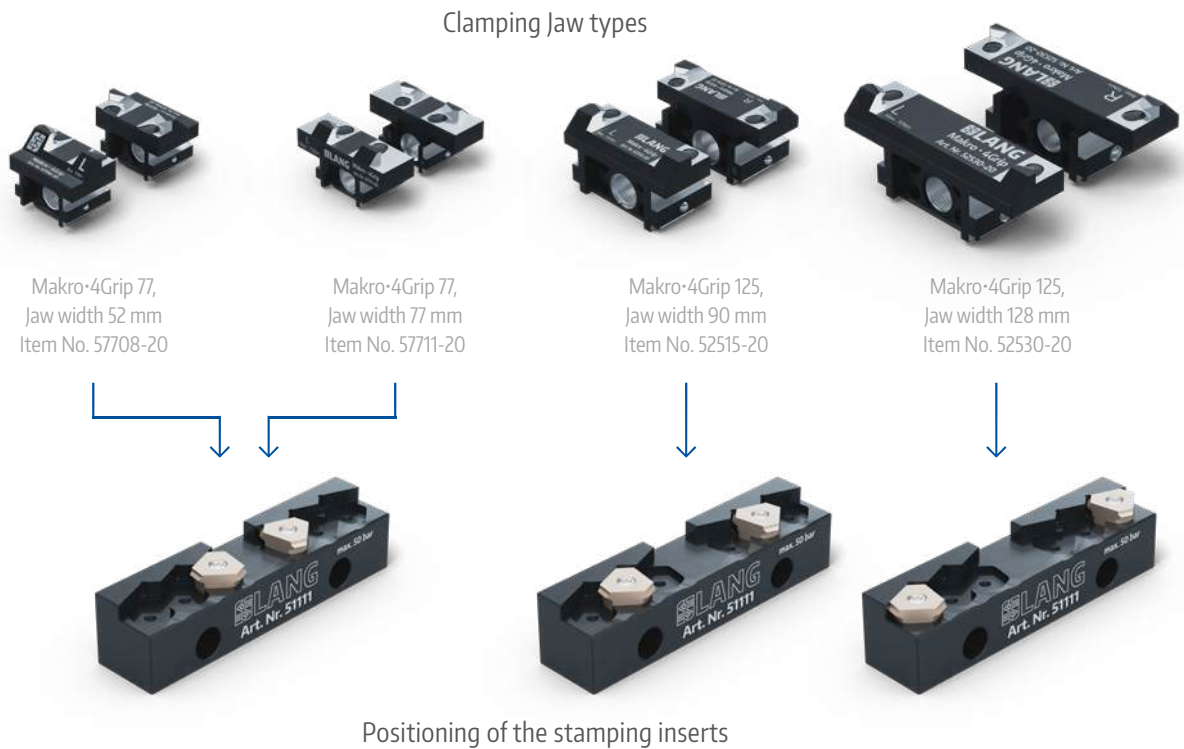

Makro·4Grip Stamping Jaws and Inserts



MAKRO·4GRIP STAMPING JAWS

ITEM NO.	QUANTITY
51111	1 pair

4 stamping jaw inserts are included.
Suitable for all Makro-Grip® stamping unit versions!

MAKRO·4GRIP STAMPING JAW INSERTS

ITEM NO.	QUANTITY
51111-40	4 pcs.

Each stamping jaw insert has a total of three cutting edges. If a cutting edge is worn, the stamping jaw insert can be turned two more times. For an even stamping and clamping quality, make sure that all four stamping inserts are turned / exchanged at the same time.

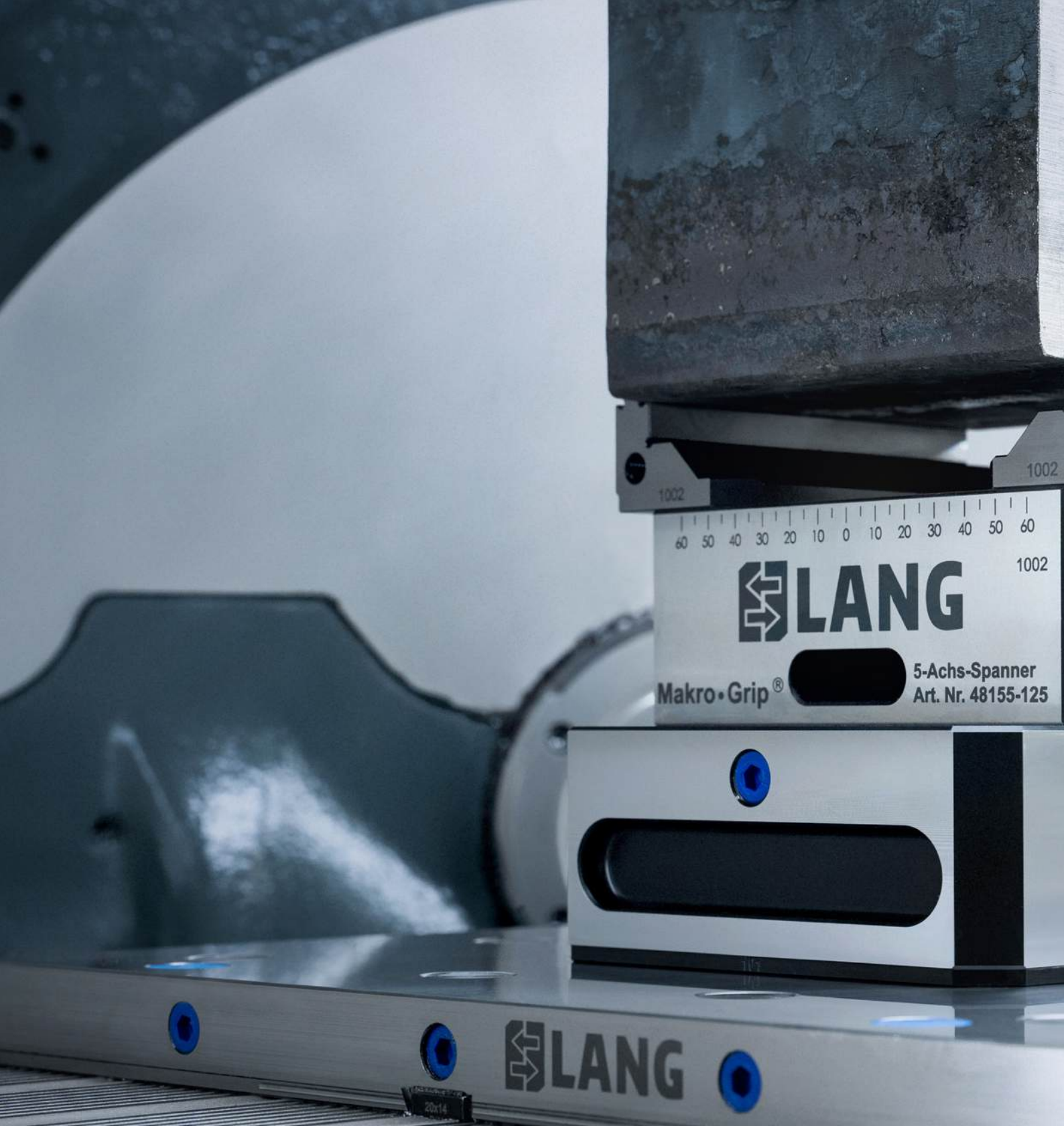

MAKRO-GRIP® RAW PART CLAMPING



- 28** Makro·Grip® 5-Axis Vises
 - 36** 5-Axis Vises 77
 - 44** 5-Axis Vises 125
- 54** Makro·Grip® Dual-Clamping Vise
 - 56** Retrofitting kit for 5-Axis Vise



simple.
reliable.
gripping.

Unbeatable combination of compactness and holding power

3 reasons why the Makro·Grip® is perfectly fitted for 5-sided machining:

ACCESSIBILITY

HOLDING POWER

PROCESS RELIABILITY

External pre-stamping enables a workpiece to be held reliably in the Makro·Grip® 5-Axis Vise with low clamping pressure. Deformation and distortion of the material during clamping are therefore excluded and wear on the clamping device is reduced to a minimum. Its compact design and the use of the form-fit technology make the 5-Axis Vise ideal for 5-sided machining.

Benefits of the Makro·Grip® 5-Axis Vise:



Ideal accessibility in 5-sided machining



Highest holding forces at low clamping pressure



Distortion-free and wear-free clamping



High material savings due to minimal clamping edge requirements



Process reliability and consistent clamping quality



Ergonomic handling thanks to low weight vises

Makro·Grip® Technology

Compact and unmatched holding power for the 5-sided machining of blanks and unfinished parts

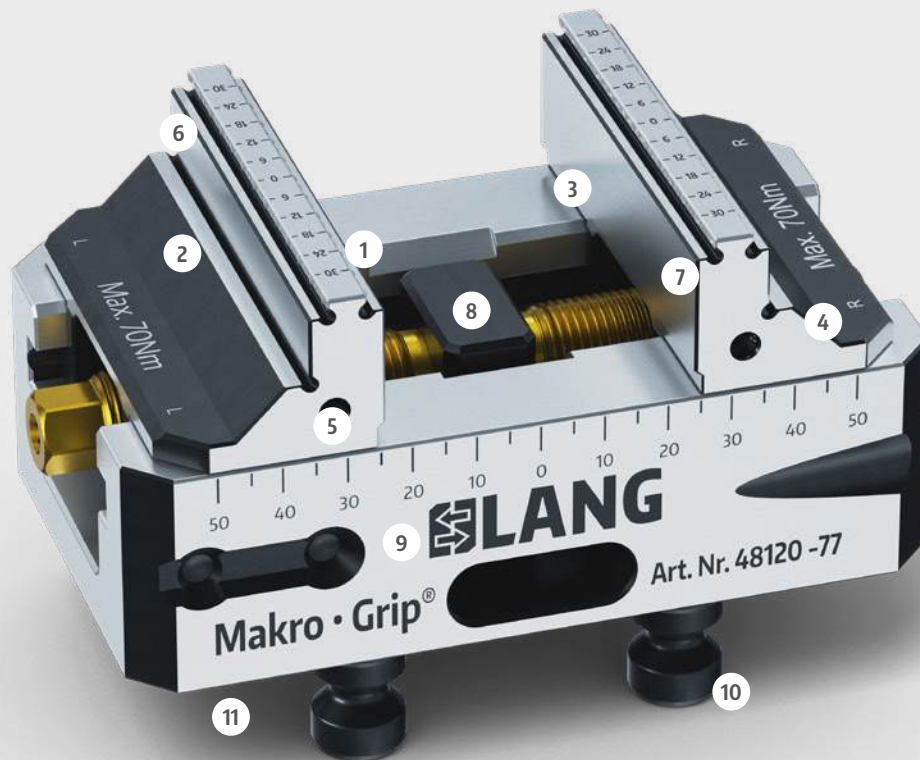

- 1 Makro·Grip® jaws with double-sided serration (same serration for all types of vises)
- 2 Additional clamping support for non-stamped parts
- 3 Special Tungsten-Carbide Coating can be applied on the plain clamping surfaces in order to increase friction when clamping non-stamped parts
- 4 Clamping jaws milled from solid case-hardened steel for maximum stability
- 5 Thread for mounting an endstop
- 6 The reversible jaws are changed over within one minute. A larger clamping range is achieved and interferences are eliminated
- 7 Clamping edge requirement of 3 mm guarantees ideal accessibility for tools and enormous material savings
- 8 Centering accuracy ± 0.02 mm
- 9 Rigid and sturdy base for great longevity. All LANG jaw types within the size group can be mounted to this base
- 10 Integrated with clamping studs for precise clamping in the Quick·Point® zero-point clamping system
- 11 Additional bores/threads can be drilled in the bottom of the base body to adapt the Makro·Grip® 5-Axis Vise to other zero-point systems

Makro-Grip® serration

All Makro-Grip® clamping jaw sizes use the double-sided serration. The minimum clamping depth of only 3 mm (other depths are available on request) guarantees ideal accessibility and enormous material savings. The Makro-Grip® serration offers exceptional reproducibility, which is particularly advantageous when workpieces have to be clamped again for reworking tasks.



Reversible clamping jaws

The reversible clamping jaws of the Makro-Grip® 5-Axis Vise are changed over within one minute. Thus, a larger clamping range is achieved and interferences are eliminated. Opposed to conventional vises whose top jaws are often mounted to the jaw guide, the Makro-Grip® jaws are milled from solid, which results in enormous stability advantages.





Robust and automation-ready

The tapered grooves on the side surface of the Makro-Grip® 77 (length 130 mm), as well as the front-end bores in the base body of the Makro-Grip® 125 (length 210 mm) are used to hold and store the 5-Axis Vise on the RoboTrex automation trolleys. Due to the upright mounting of the vises, the RoboTrex storage medium offers an excellent ratio of space requirement and storage capacity. The 5-Axis Vises are also equipped with grooves for the RoboTrex gripper.

Integrated zero-point adaptation

All LANG vise versions are equipped with clamping studs for precise clamping in the Quick-Point® zero-point clamping system. They are clamped with a repeat accuracy of < 0.005 mm and holding forces of up to up to 6,000 kg.

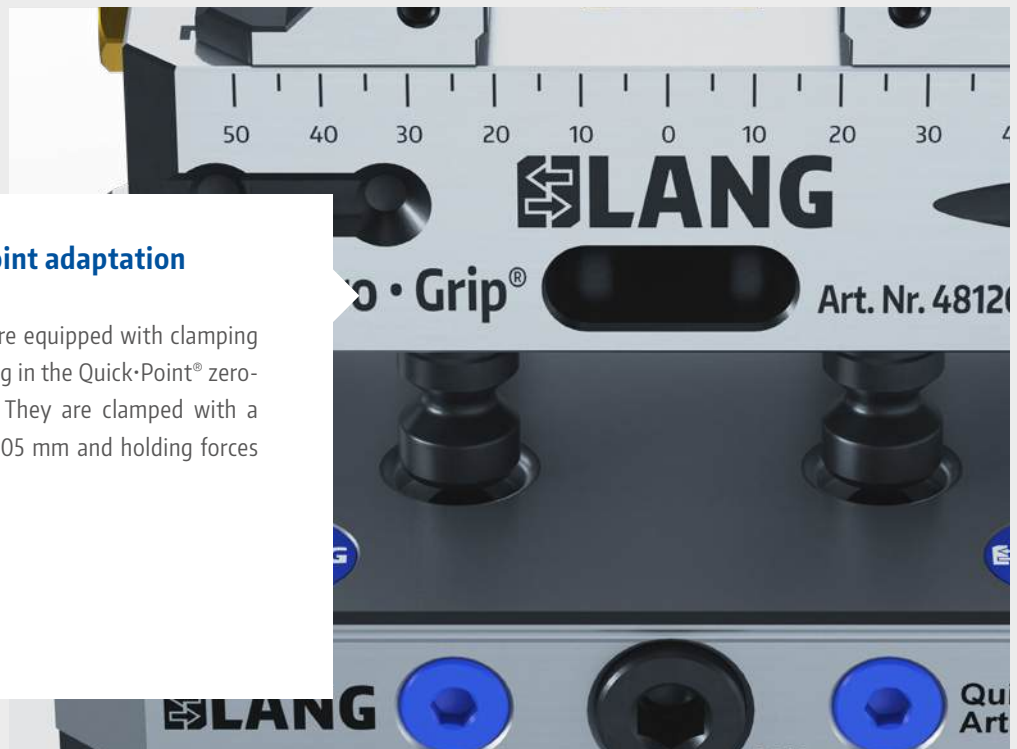

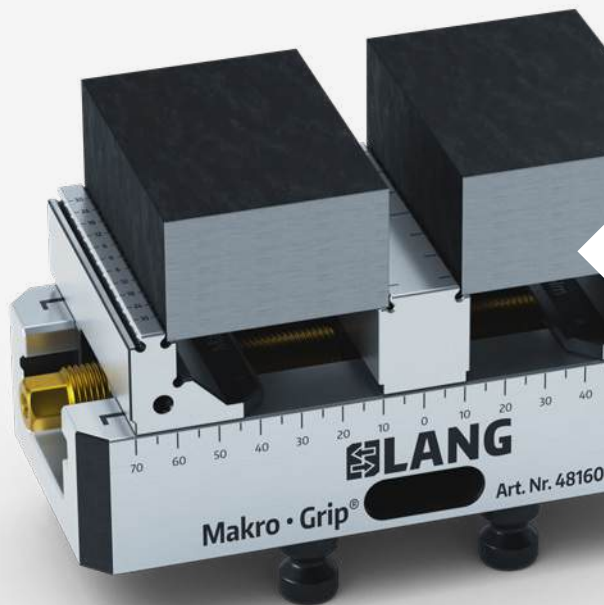

Single or multiple clamping

Due to the encapsulated center piece, the guide of the TIN-coated threaded spindle is protected against dirt and chips. Replacing the center piece / spindle set with a center jaw conversion kit, the Makro-Grip® is transformed into a multiple clamping vise, in which several workpieces can be clamped simultaneously.

Additional clamping possibilities

With their plain surfaces and clamping steps, Makro-Grip® jaws also offer various clamping options for 2nd operations or for workpieces that are not to be pre-stamped. Makro-Grip® clamping jaws are available with or without serration and are equipped with threaded holes on their side face to attach endstops. Besides, a special Tungsten-Carbide coating can be applied on the plain clamping surfaces in order to double the friction force when clamping non-stamped parts.



Different versions of the 5-Axis Vise

Makro·Grip® 5-Axis Vise 77

Base width:
77 mm



Jaw width: 46 mm
Base lengths: 102 / 130 mm



Jaw width: 77 mm
Base lengths:
102 / 130 / 170 / 210 mm



Jaw width: 77 mm
Base length: 130 mm

Makro·Grip® Night King:
A pure 5-Axis Vise for automated
manufacturing with RoboTrex.

To be found in the automation brochure.

Makro·Grip® 5-Axis Vise 125

Base width:
125 mm



Jaw width: 77 mm
Base lengths: 160 / 210 mm

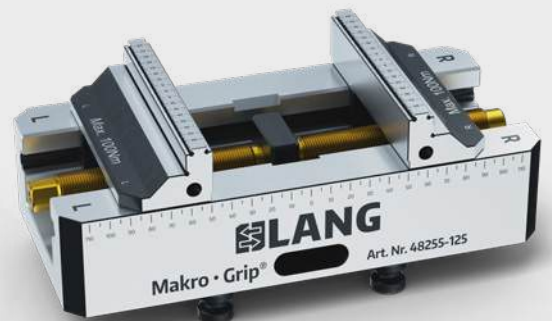

Jaw width: 125 mm
Base lengths:
160 / 210 / 260 / 310 / 360 mm

The benefits of pre-stamping on the clamping process

The external pre-stamping of the workpiece relieves the 5-Axis Vise. While conventional machining vises with serration have to work double duty (1. indent the material, 2. hold the workpiece), the Makro-Grip® 5-Axis Vise's function is limited to only holding

the workpiece. The compact build of the Makro-Grip® 5-Axis Vise is possible due to the requirement of much lower clamping forces. The resulting advantages are shown below.

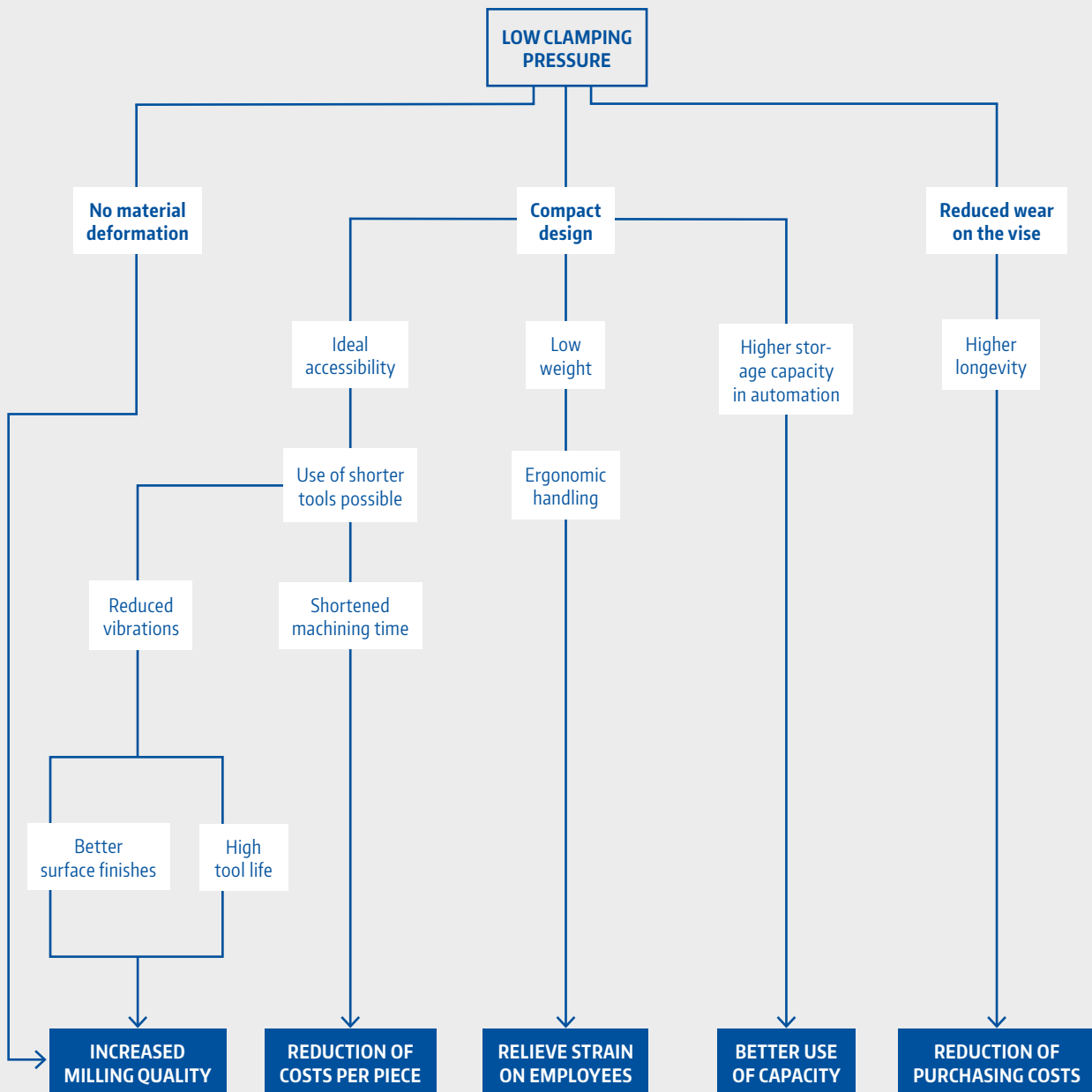

Clamping pressure – holding force ratio

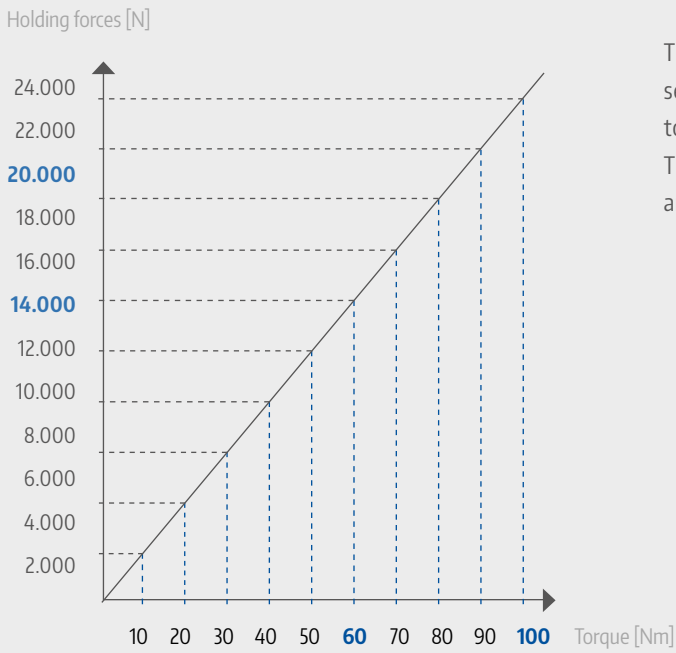

Thanks to the form-fit clamping technology, workpieces can be securely clamped with low clamping pressure. Deformation and distortion of the material while clamping and releasing is impossible! This diagram highlights the relation between the actuation torque and the resulting holding forces.

Applications

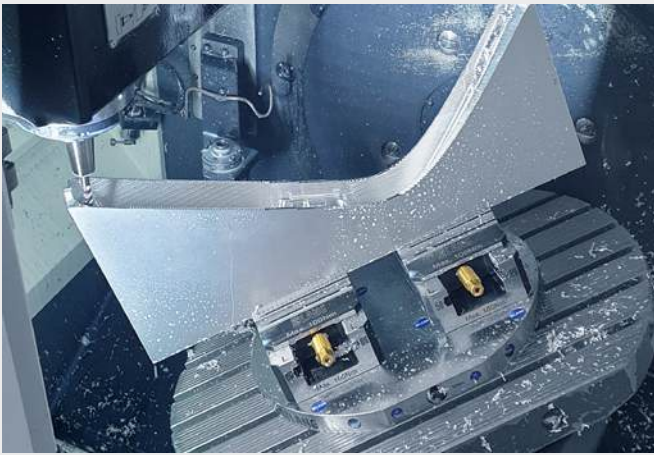

Image: Aximech AB

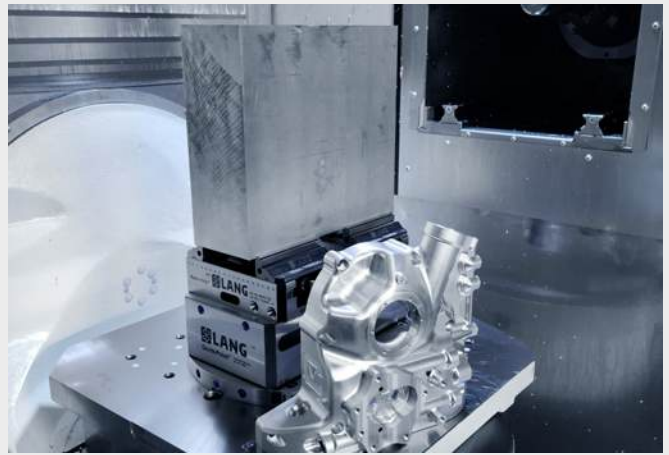

Image: Chips Motorsports LLC

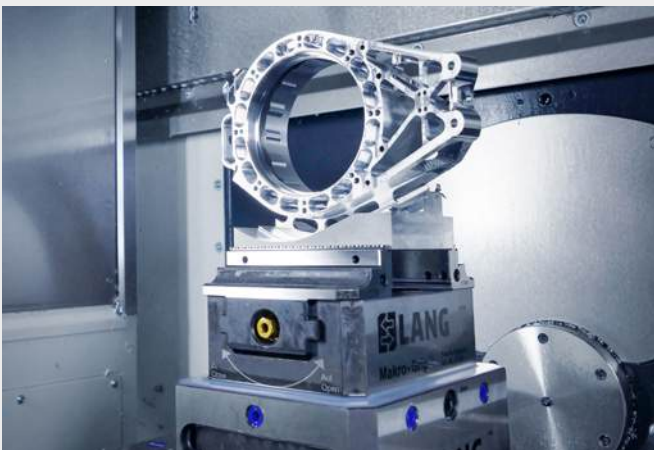

Image: Donner GmbH The Qualifactory
34



Image: Nueva Precision



One base, many clamping jaw options

A fitting solution for any challenging clamping task – with only one vise base! All LANG vises use the same base in different lengths and widths. This guarantees that all jaw types are interchangeable and compatible to each other. It also means that you do not necessarily

have to invest in two vises. The interchangeability of the jaws allows you to build a flexible "vise fleet" regardless of the vise type you start with. Additional jaws can be added at a later time according to demand and application.

Makro·Grip® 5-Axis Vise 77

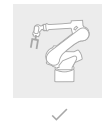

MAKRO·GRIP® 5-AXIS VISE 77, JAW WIDTH 46 MM



ITEM NO.	BASE LENGTH	CLAMPING RANGE	WEIGHT
48085-46	102 mm	0 - 85 mm	2.1 kg
48120-46	130 mm	0 - 120 mm	2.6 kg

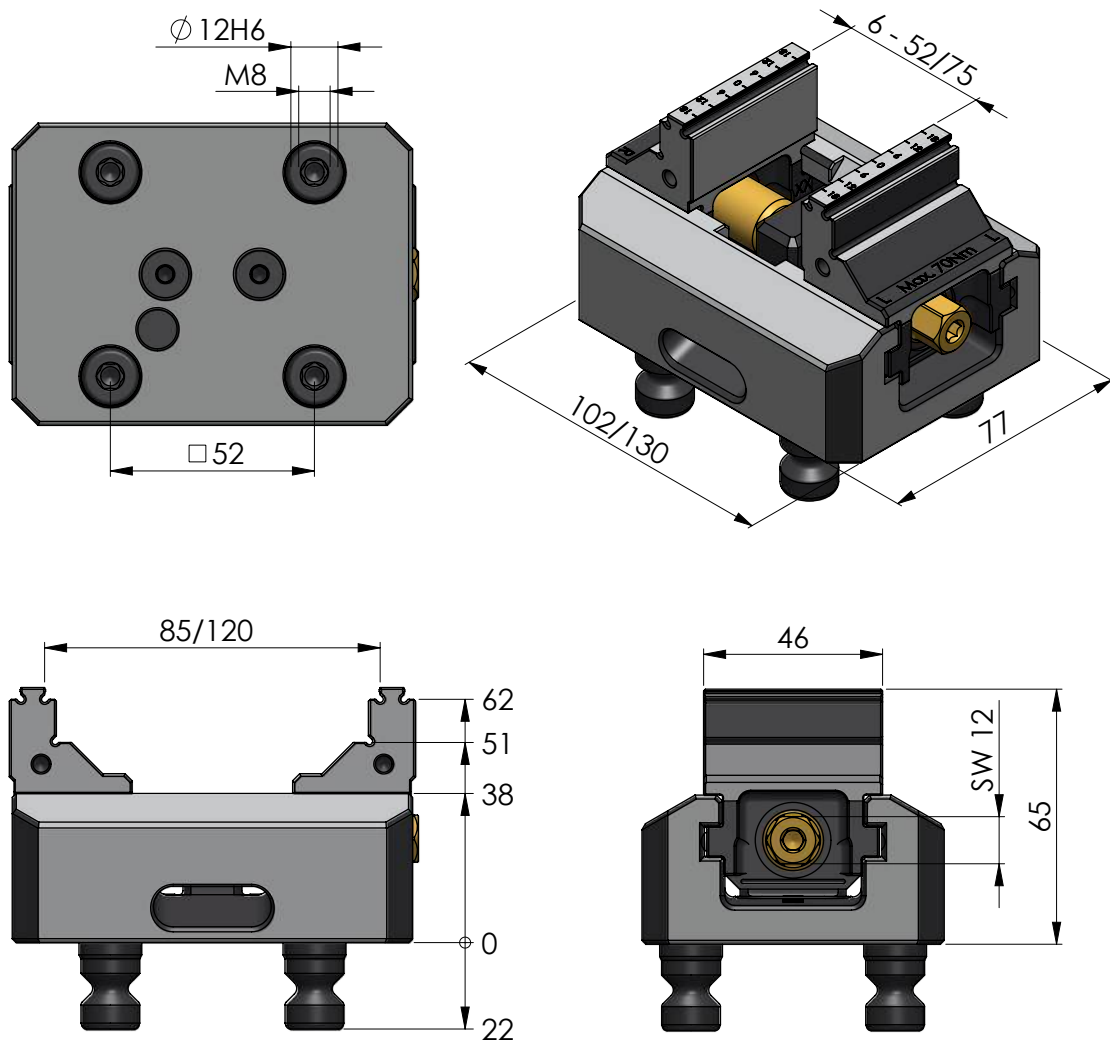

Spare parts and accessories



Spare jaws and compatible jaw types can be found on pages 40 – 43.

Spindles and other accessories such as wrenches can be found on pages 52 / 53.

Makro·Grip® 5-Axis Vise 77



MAKRO·GRIP® 5-AXIS VISE 77, JAW WIDTH 77 MM

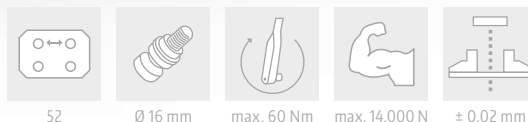

ITEM NO.	BASE LENGTH	CLAMPING RANGE	WEIGHT	COMPARABLE PREVIOUS VERSION
48085-77	102 mm	0 – 85 mm	2.4 kg	47085
48120-77	130 mm	0 – 120 mm	2.9 kg	47120
48160-77	170 mm	0 – 160 mm	3.6 kg	47160
48200-77	210 mm	0 – 200 mm	4.2 kg	47200

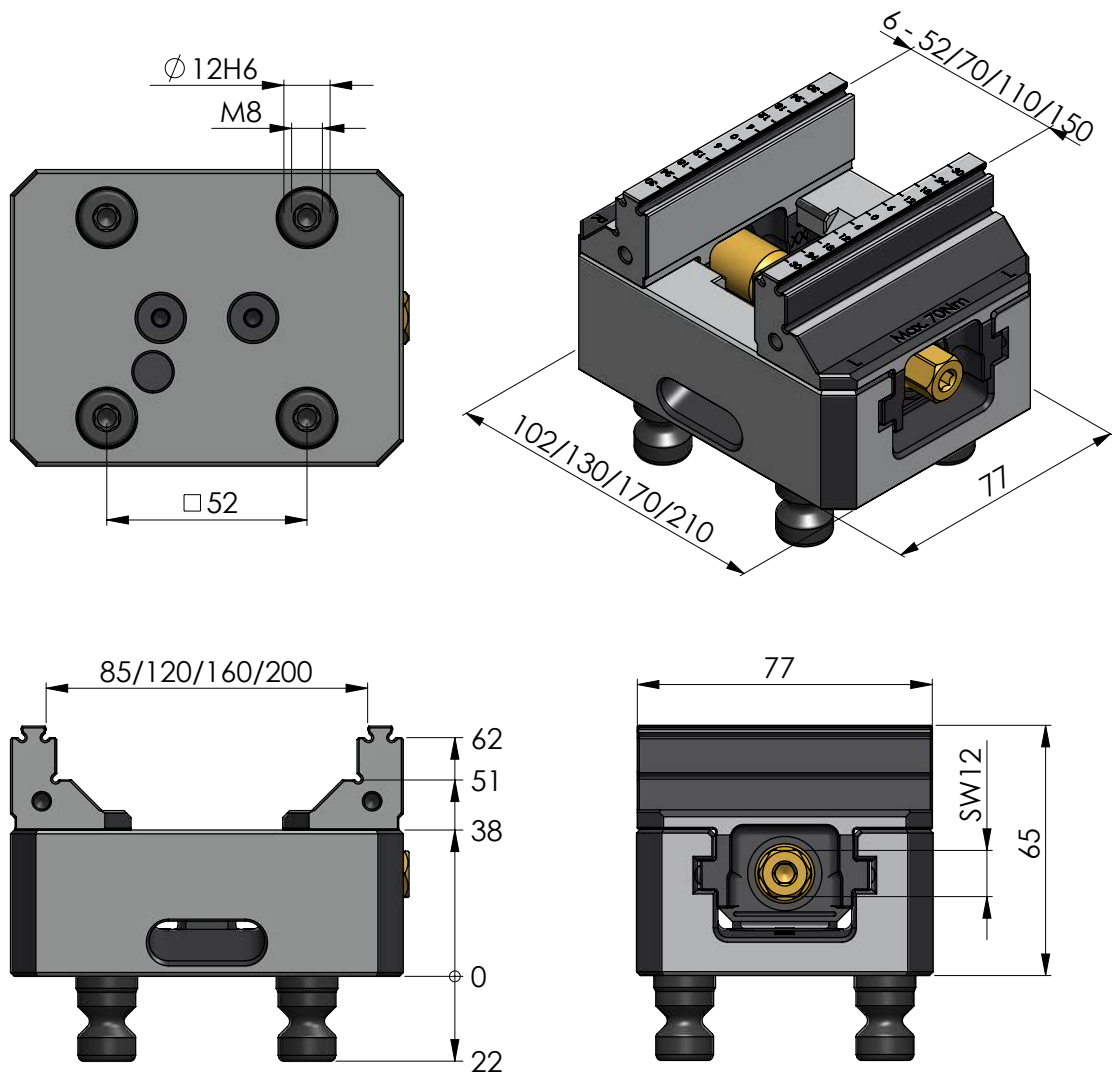

Spare parts and accessories



Spare jaws and compatible jaw types can be found on pages 40 – 43.



Spindles and other accessories such as wrenches can be found on pages 52 / 53.

Makro·Grip® 5-Axis Vise 77

Available Clamping Jaws

The Makro·Grip® spare jaws milled from solid material with jaw widths of 46 mm and 77 mm are suitable for all LANG vise types with a base body width of 77 mm. Thanks to the serration on both sides, the spare jaws can be reversed to achieve a clamping range that corresponds to almost the entire length of the base body, thus ensuring ideal accessibility with low interference contours. Workpieces can be held in the serration at a clamping depth of 3 mm by form-fit. In addition, the replacement jaws offer smooth clamping possibilities for the second operation.

If a form-fit clamping via the Makro·Grip® serration, in which the gripping contour remains in the workpiece, is not possible or desired, but you still want to benefit from the minimum clamping depth of 3 mm, workpieces can be clamped plainly with spare jaws without serration.



SPARE JAWS FOR MAKRO·GRIP® 5-AXIS VISE 77, JAW WIDTH 46 MM

ITEM NO.	TYPE	FOR	WEIGHT	UNIT
48077-4620	with Makro·Grip® serration	48120-46	0.5 kg	1 pair
48077-4622	with plain clamping step	48120-46	0.5 kg	1 pair
48085-4620	with Makro·Grip® serration	48085-46	0.5 kg	1 pair
48085-4622	with plain clamping step	48085-46	0.5 kg	1 pair



SPARE JAWS FOR MAKRO·GRIP® 5-AXIS VISE 77, JAW WIDTH 77 MM

ITEM NO.	TYPE	FOR	WEIGHT	UNIT
48077-7720	with Makro·Grip® serration	48120-77 48160-77 48200-77	0.8 kg	1 pair
48077-7722	with plain clamping step	48120-77 48160-77 48200-77	0.8 kg	1 pair
48085-7720	with Makro·Grip® serration	48085-77	0.8 kg	1 pair
48085-7722	with plain clamping step	48085-77	0.8 kg	1 pair



AVANTI BASE JAWS FOR MAKRO·GRIP® 5-AXIS VISE 77

ITEM NO.	FOR	WEIGHT	UNIT
44771-46	48085-46 / 48120-46	0.6 kg	1 pair
44771-77	48120-77 48160-77 / 48200-77	1.4 kg	1 pair

The patented interface of the Avanti base jaws ensures highly accurate positioning of the top jaws, which are clamped with just one screw and allow jaws to be changed in a matter of seconds. Since all LANG vises use the same base body, the Avanti base jaws are compatible with the Makro·Grip® 5-Axis Vise and can be used on it as a complementary pair of jaws for the rear-side machining.



PROFILO BASE JAWS FOR MAKRO·GRIP® 5-AXIS VISE 77

ITEM NO.	FOR	WEIGHT	UNIT
49077	all Makro·Grip® 77, jaw width 77 mm	1.6 kg	1 pair

Top jaws are positioned on the Profilo base jaws via feather keys and fastened from below with four screws. In addition to top jaws available from LANG, self-made top jaws can also be used on them. Since all LANG vises use the same base body, the Profilo base jaws are compatible with the Makro·Grip® 5-Axis Vise and can be used on the latter as a complementary pair of jaws for the rear-side machining.



VARIO·TEC JAWS FOR MAKRO·GRIP® 5-AXIS VISE 77

ITEM NO.	FOR	WEIGHT	UNIT
42018-77	48120-77 / 48160-77 / 48200-77	1.2 kg	1 Set (2 pin jaws + 2 carrier jaws)

The Vario-Tec spare jaw pair consists of two pin jaws and two carrier jaws, which are guided in the centering vise. The pin jaws are attached to the receiving jaws from the rear, so that the pin jaws are completely closed up front and clogging is avoided. Since all LANG vises use the same base body, the Vario-Tec jaw set is compatible with the Makro·Grip® 5-Axis Vise and can be used on the latter as a complementary pair of jaws for the rear-side machining.

Makro·4Grip 77 Clamping Jaws

Makro·4Grip clamping jaws are used to hold pre-stamped round workpieces by form-fit. The clamping jaws are available for all vise types and lengths. The pair of jaws grips the pre-stamped workpiece at a total of 4 clamping points with a holding force of 14 kN. Depending on the base body length, workpieces with a diameter between Ø 36 - 115 mm can be clamped. 3D view models for the individual clamping ranges can be found on the respective product page.



MAKRO·4GRIP 77 CLAMPING JAWS, JAW WIDTH 52 MM, ITEM NO. 57708-20

FOR MAKRO·GRIP® 77	CLAMPING RANGE
48085-46 -77	Ø 36 - 60 mm
48120-46 -77	Ø 36 - 85 mm
48160-77	Ø 36 - 115 mm
48200-77	Ø 36 - 115 mm
47085*	Ø 43 - 60 mm
47120*	Ø 43 - 85 mm
47160*	Ø 43 - 115 mm
47200*	Ø 43 - 115 mm

* former Makro·Grip® versions



MAKRO·4GRIP 77 CLAMPING JAWS, JAW WIDTH 77 MM, ITEM NO. 57711-20

FOR MAKRO·GRIP® 77	CLAMPING RANGE
48085-46 -77	Ø 54 - 80 mm
48120-46 -77	Ø 54 - 115 mm
48160-77	Ø 54 - 115 mm
48200-77	Ø 54 - 115 mm
47085*	Ø 65 - 80 mm
47120*	Ø 65 - 115 mm
47160*	Ø 65 - 115 mm
47200*	Ø 65 - 115 mm

* former Makro·Grip® versions

Makro·Grip® 77 Contour Jaws

NEW

The latest generation of Makro·Grip® contour jaws offers convincing ease of use. The contour jaws are attached without changing the Makro·Grip® clamping jaws and without tools, which guarantees a pleasant setup process in seconds. In the process, the contour jaws snap into the Makro·Grip® serration with their stamping contour and hold them in position. Magnets finally pull the contour jaws towards the clamping jaws and ensure a firm fit.

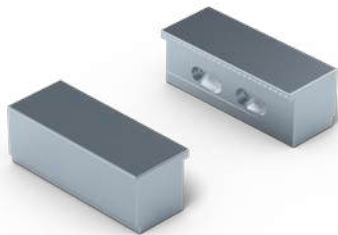

CONTOUR JAWS, ALUMINIUM FOR MAKRO·GRIP® 5-AXIS VISES 77

ITEM NO.	JAW WIDTH	FOR	WEIGHT	UNIT
48409-77	77 mm	inside	0.3 kg	1 pair

Suitable magnets are available separately, as is the assembly tool.

FOR MAKRO·GRIP®	CLAMPING RANGE
48085-77	x
48120-77	50 mm
48160-77	90 mm
48200-77	130 mm
48155-77	40 mm
48205-77	90 mm

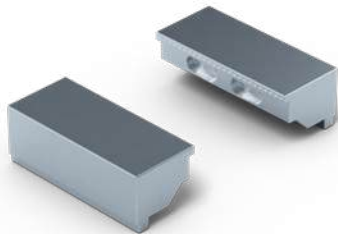

CONTOUR JAWS, ALUMINIUM FOR MAKRO·GRIP® 5-AXIS VISES 77

ITEM NO.	JAW WIDTH	FOR	WEIGHT	UNIT
48419-77	77 mm	outside	0.3 kg	1 pair

Suitable magnets are available separately, as is the assembly tool.

FOR MAKRO·GRIP®	CLAMPING RANGE
48085-77	60 mm
48120-77	100 mm
48160-77	140 mm
48200-77	180 mm
48155-77	-
48205-77	-

CONTOUR JAWS ACCESSORIES

ITEM NO.	DESCRIPTION	WEIGHT	UNIT
48410	Magnet Set	0.02 kg	Set of 10
48420	Magnet Assembly Tool	0.01 kg	1 piece

Suitable for all sizes of Makro·Grip® Contour Jaws.



Makro·Grip® 5-Axis Vise 125



MAKRO·GRIP® 5-AXIS VISE 125, JAW WIDTH 77 MM



ITEM NO.	BASE LENGTH	CLAMPING RANGE	WEIGHT
48155-77	160 mm	0 – 155 mm	7.4 kg
48205-77	210 mm	0 – 205 mm	9.1 kg

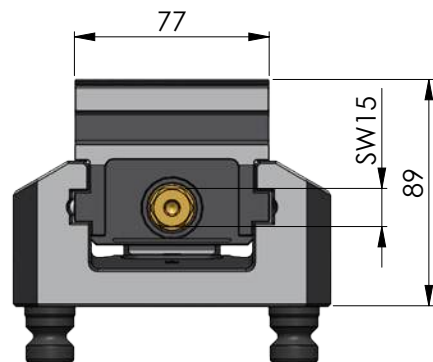
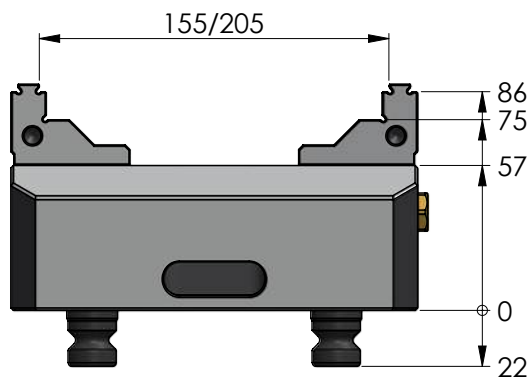
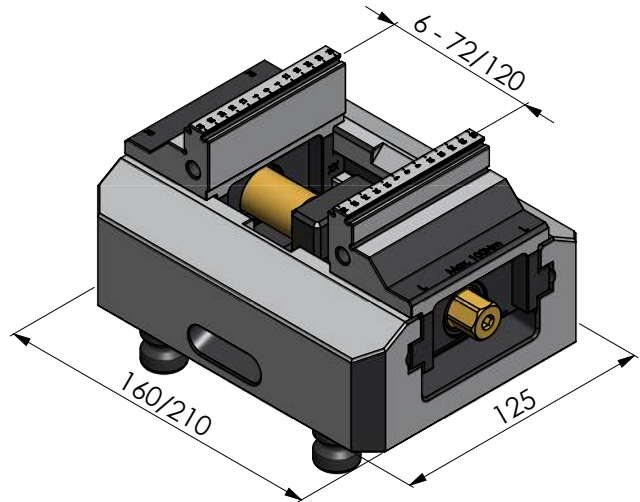
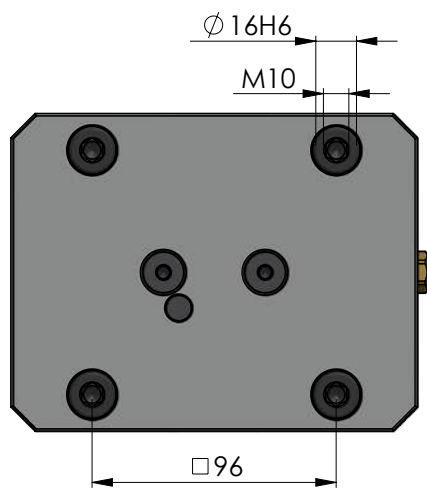

Spare parts and accessories



Spare jaws and compatible jaw types can be found on pages 48 – 51.

Spindles and other accessories such as wrenches can be found on pages 52 / 53.

Makro·Grip® 5-Axis Vise 125

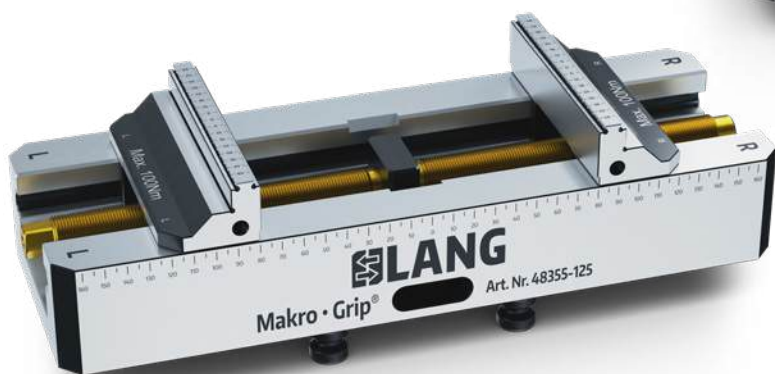
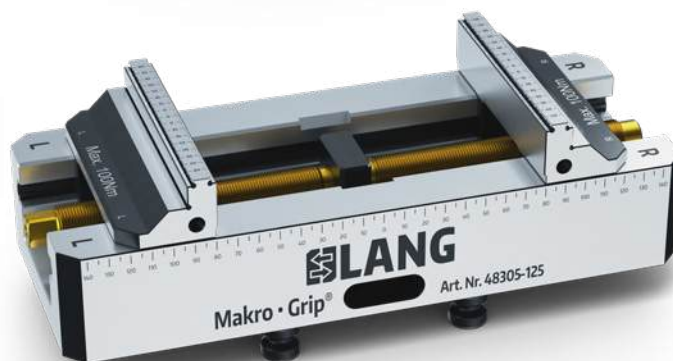
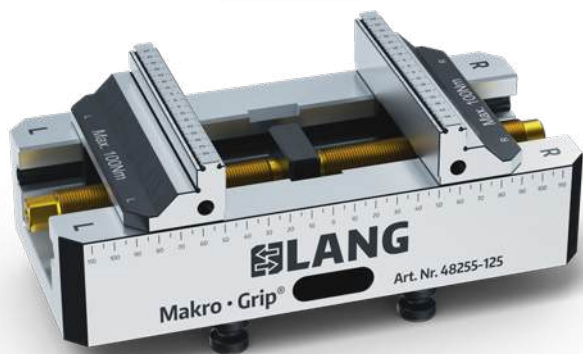
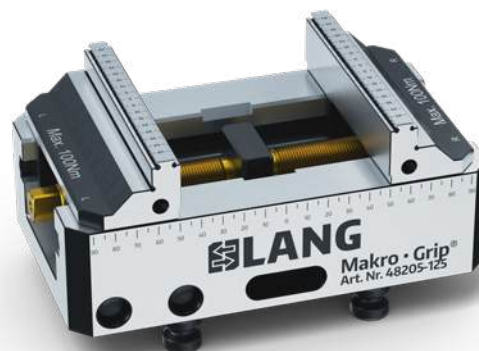

MAKRO·GRIP® 5-AXIS VISE 125, JAW WIDTH 125 MM



ITEM NO.	BASE LENGTH	CLAMPING RANGE	WEIGHT	COMPARABLE PREVIOUS VERSION
48155-125	160 mm	0 - 155 mm	8.4 kg	47155
48205-125	210 mm	0 - 205 mm	10.1 kg	47205
48255-125	260 mm	0 - 255 mm	12.1 kg	47255
48305-125	310 mm	0 - 305 mm	13.9 kg	47305
48355-125	360 mm	0 - 355 mm	15.7 kg	47355

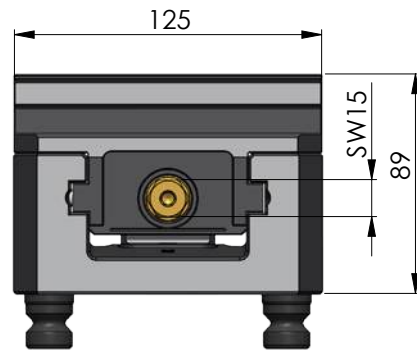
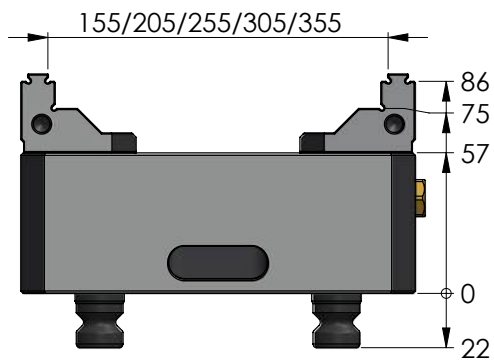
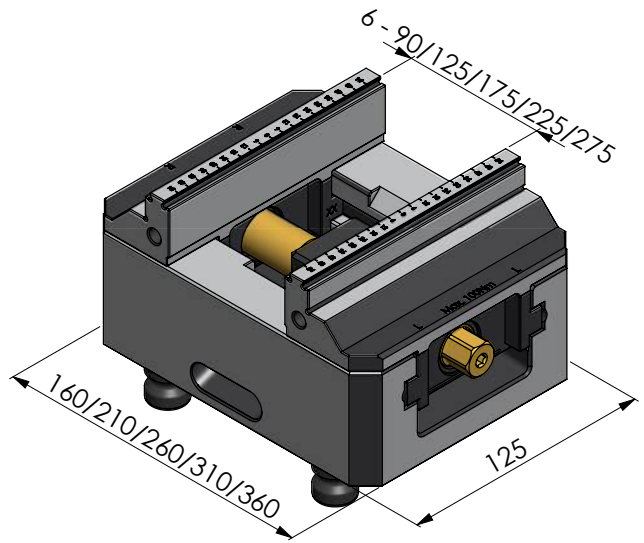
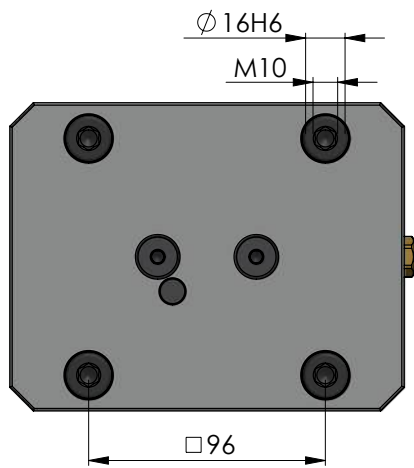

Spare parts and accessories



Spare jaws and compatible jaw types can be found on pages 48 – 51.

Spindles and other accessories such as wrenches can be found on pages 52 / 53.

Makro-Grip® 5-Axis Vise 125

Available Clamping Jaws

The Makro-Grip® spare jaws milled from solid material with jaw widths of 77 mm and 125 mm are suitable for all LANG vise types with a base body width of 125 mm. Thanks to the serration on both sides, the spare jaws can be reversed to achieve a clamping range that corresponds to almost the entire length of the base body, thus ensuring ideal accessibility with low interference contours. Workpieces can be held in the serration at a clamping depth of 3 mm by form-fit. In addition, the replacement jaws offer smooth clamping possibilities for the second operation.

If a form-fit clamping via the Makro-Grip® serration, in which the gripping contour remains in the workpiece, is not possible or desired, but you still want to benefit from the minimum clamping depth of 3 mm, workpieces can be clamped plainly with these spare jaws without serration.



SPARE JAWS FOR MAKRO-GRIP® 5-AXIS VISE 125, JAW WIDTH 77 MM

ITEM NO.	TYPE	FOR	WEIGHT	UNIT
48125-7720	with Makro-Grip® serration	all Makro-Grip® 125, jaw width 77 mm	2.0 kg	1 pair
48125-7722	with plain clamping step	all Makro-Grip® 125, jaw width 77 mm	2.0 kg	1 pair



SPARE JAWS FOR MAKRO-GRIP® 5-AXIS VISE 125, JAW WIDTH 125 MM

ITEM NO.	TYPE	FOR	WEIGHT	UNIT
48125-2520	with Makro-Grip® serration	all Makro-Grip® 125, jaw width 125 mm	2.6 kg	1 pair
48125-2522	with plain clamping step	all Makro-Grip® 125, jaw width 125 mm	2.6 kg	1 pair



AVANTI BASE JAWS FOR MAKRO·GRIP® 5-AXIS VISE 125

ITEM NO.	FOR	WEIGHT	UNIT
44251-125	all Makro-Grip® 125, jaw width 125 mm	3.6 kg	1 pair

The patented interface of the Avanti base jaws ensures highly accurate positioning of the top jaws, which are clamped with just one screw and allow jaws to be changed in a matter of seconds. Since all LANG vises use the same base body, the Avanti base jaws are compatible with the Makro-Grip® 5-Axis Vise and can be used on it as a complementary pair of jaws for the rear-side machining.



PROFILO BASE JAWS FOR MAKRO·GRIP® 5-AXIS VISE 125

ITEM NO.	FOR	WEIGHT	UNIT
49125	all Makro-Grip® 125, jaw width 125 mm	4.2 kg	1 pair

Top jaws are positioned on the Profilo base jaws via feather keys and fastened from below with four screws. In addition to top jaws available from LANG, self-made top jaws can also be used on them. Since all LANG vises use the same base body, the Profilo base jaws are compatible with the Makro-Grip® 5-Axis Vise and can be used on the latter as a complementary pair of jaws for the rear-side machining.



VARIO·TEC JAWS FOR MAKRO·GRIP® 5-AXIS VISE 77

ITEM NO.	FOR	WEIGHT	UNIT
42018-125	all Makro-Grip® 125, jaw width 125 mm	4.6 kg	1 Set (2 pin jaws + 2 carrier jaws)

The Vario-Tec spare jaw pair consists of two pin jaws and two carrier jaws, which are guided in the centering vise. The pin jaws are attached to the receiving jaws from the rear, so that the pin jaws are completely closed up front and clogging is avoided. Since all LANG vises use the same base body, the Vario-Tec jaw set is compatible with the Makro-Grip® 5-Axis Vise and can be used on the latter as a complementary pair of jaws for the rear-side machining.

Makro·4Grip 125 Clamping Jaws

Makro·4Grip clamping jaws are used to hold pre-stamped round workpieces by form-fit. The clamping jaws are available for all vise types and lengths. The pair of jaws grips the pre-stamped workpiece at a total of 4 clamping points with a holding force of 20 kN. Depending on the base body length, workpieces with a diameter between Ø 115 - 300 mm can be clamped. 3D view models for the individual clamping ranges can be found on the respective product page.



MAKRO·4GRIP 125 CLAMPING JAWS, JAW WIDTH 90 MM, ITEM NO. 52515-20

FOR MAKRO·GRIP® 125	CLAMPING RANGE
48155-77 / -125	-
48205-77 / -125	Ø 115 - 130 mm
48255-125	Ø 115 - 180 mm
48305-125	Ø 115 - 180 mm
48355-125	Ø 115 - 180 mm
47155*	-
47205*	Ø 115 - 130 mm
47255*	Ø 115 - 180 mm
47305*	Ø 115 - 180 mm
47355*	Ø 115 - 180 mm

* former Makro·Grip® versions



MAKRO·4GRIP 125 CLAMPING JAWS, JAW WIDTH 128 MM, ITEM NO. 52530-20

FOR MAKRO·GRIP® 125	CLAMPING RANGE
48155-77 / -125	-
48205-77 / -125	Ø 180 - 200 mm
48255-125	Ø 180 - 245 mm
48305-125	Ø 180 - 290 mm
48355-125	Ø 180 - 300 mm
47155*	-
47205*	Ø 180 - 200 mm
47255*	Ø 180 - 245 mm
47305*	Ø 180 - 290 mm
47355*	Ø 180 - 300 mm

* former Makro·Grip® versions

Makro·Grip® 77 and 125 Contour Jaws

NEW

The latest generation of Makro·Grip® contour jaws offers convincing ease of use. The contour jaws are attached without changing the Makro·Grip® clamping jaws and without tools, which guarantees a pleasant setup process in seconds. In the process, the contour jaws snap into the Makro·Grip® serration with their stamping contour and hold them in position. Magnets finally pull the contour jaws towards the clamping jaws and ensure a firm fit.



CONTOUR JAWS, ALUMINIUM FOR MAKRO·GRIP® 5-AXIS VISES 77 / 125

ITEM NO.	JAW WIDTH	FOR	WEIGHT	UNIT
48409-77	77 mm	inside	0.3 kg	1 pair
48409-125	125 mm	inside	0.6 kg	1 pair

Suitable magnets are available separately, as is the assembly tool.

FOR MAKRO·GRIP®	48409-77	48409-125	FOR MAKRO·GRIP®	48409-77	48409-125
CLAMPING RANGE:			CLAMPING RANGE		
48085-77	x	x	48155-125	x	40 mm
48120-77	50 mm	x	48205-125	x	90 mm
48160-77	90 mm	x	48255-125	x	140 mm
48200-77	130 mm	x	48305-125	x	190 mm
48155-77	40 mm	x	48355-125	x	240 mm
48205-77	90 mm	x			



CONTOUR JAWS, ALUMINIUM FOR MAKRO·GRIP® 5-AXIS VISES 77 / 125

ITEM NO.	JAW WIDTH	FOR	WEIGHT	UNIT
48419-77	77 mm	outside	0.3 kg	1 pair
48419-125	125 mm	outside	0.6 kg	1 pair

Suitable magnets are available separately, as is the assembly tool.

FOR MAKRO·GRIP®	48419-77	48419-125	FOR MAKRO·GRIP®	48419-77	48419-125
CLAMPING RANGE			CLAMPING RANGE		
48085-77	60 mm	x	48155-125	x	120 mm
48120-77	100 mm	x	48205-125	x	170 mm
48160-77	140 mm	x	48255-125	x	220 mm
48200-77	180 mm	x	48305-125	x	270 mm
48155-77	x	x	48355-125	x	320 mm
48205-77	x	x			



CONTOUR JAWS ACCESSORIES

ITEM NO.	DESCRIPTION	WEIGHT	UNIT
48410	Magnet Set	0.02 kg	Set of 10
48420	Magnet Assembly Tool	0.01 kg	1 piece

Suitable for all sizes of Makro·Grip® Contour Jaws.

Makro·Grip® 5-Axis Vises

Spare Parts



SPARE SPINDLE + CENTER PIECE FOR MAKRO·GRIP® 5-AXIS VISE 77

ITEM NO.	FOR	SPINDLE LENGTH	WEIGHT
4877100	48085-46 / 48085-77	100 mm	0.2 kg
4877135	48120-46 / 48120-77	135 mm	0.3 kg
4877175	48160-77	175 mm	0.3 kg
4877215	48200-77	215 mm	0.4 kg

Threaded spindle with low-wear TIN coating with internal hexagon (size 5) and external hexagon (size 12).

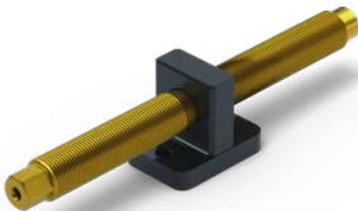

SPARE SPINDLE + CENTER PIECE FOR MAKRO·GRIP® 5-AXIS VISE 125

ITEM NO.	FOR	SPINDLE LENGTH	WEIGHT
4825164	48155-77 / 48155-125	164 mm	0.6 kg
4825214	48205-77 / 48205-125	214 mm	0.7 kg
4825264	48255-125	264 mm	0.8 kg
4825314	48305-125	314 mm	0.9 kg
4825364	48355-125	364 mm	1.0 kg

Threaded spindle with low-wear TIN coating with internal hexagon (size 5) and external hexagon (size 15)



Practical hint:

Replacing the center piece (+ threaded spindle) with a center jaw (+ threaded spindle) transforms your 5-Axis Vise into a multiple clamping vise. For more information, see pages 54 – 57.

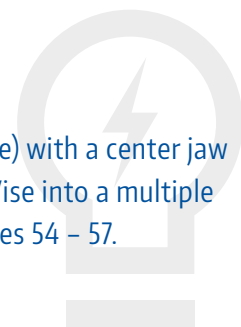

Makro·Grip® 5-Axis Vises Accessories



WRENCH FOR MAKRO·GRIP® 5-AXIS VISE

ITEM NO.	FOR	VICE SIZE	WRENCH SIZE
45500	External Hexagon	77	12 mm
45501	External Hexagon	125	15 mm
45505	Internal Hexagon	77 / 125	5 mm

Wrenches for pre-adjusting the clamping range, initial clamping setting (external hexagon) and reversing the clamping jaws (internal hexagon).



HEXAGON SOCKET

ITEM NO.	SQUARE DRIVE	VICE SIZE	WRENCH SIZE
45508	3/8"	77	12 mm
45509	3/8"	125	15 mm

Hexagon Socket (DIN 3120) for a consistent and safe clamping process.



CORDLESS DRILL ATTACHMENT

ITEM NO.	FOR	SIZE
47005	Internal Hexagon	5 mm

The cordless drill attachment is used to achieve centering accuracy of the jaws easier when exchanging them, especially with longer vise bases. You will also speed-up the exchange or reversal of jaws by using the cordless drill attachment.

Service



TUNGSTEN-CARBIDE-COATING FOR MAKRO·GRIP® JAWS

ITEM NO.	JAW WIDTH	QUANTITY
45046-17	46 mm	per pair
45077-17	77 mm	per pair
45125-17	125 mm	per pair

A special Tungsten-Carbide-Coating can be applied on the jaws' planar surfaces in order to intensify the friction when clamping non-stamped workpieces.

(Attention: Included in price is only the coating, not the jaws.)

Makro·Grip® Dual Clamping Vise – Retrofitting Kit for 5-Axis Vises

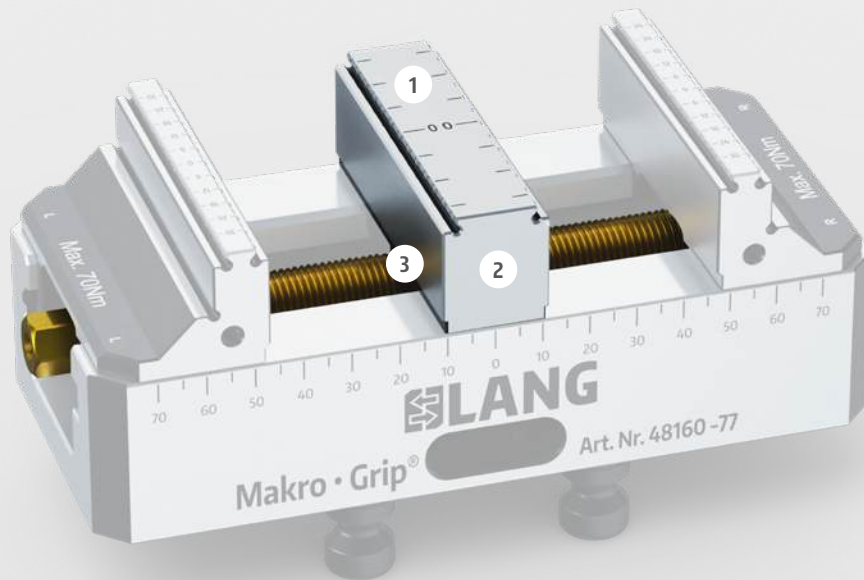

Please read all about the Makro·Grip® 5-Axis Vise's features on page 28.

- 1 Scope of delivery: Center jaw with double-sided serration and threaded spindle
- 2 For jaw widths 46 and 77 mm we offer a narrow (17 mm) and a wider (27 mm) version in order to increase the clearance between the workpieces and thus to be able to use larger tool diameters.
- 3 Conception of the center piece allows to clamp workpieces with 2 mm variance in length (cutting tolerance)

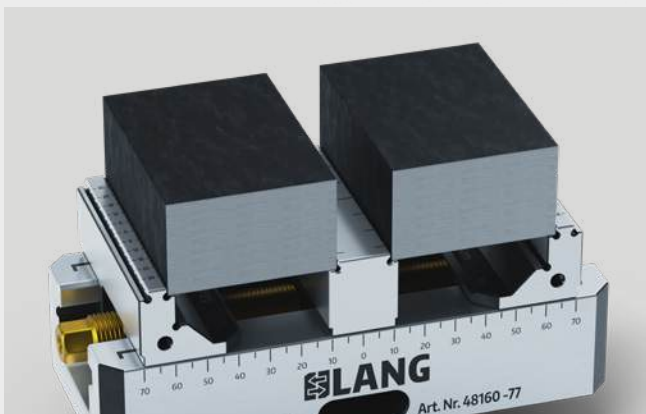

Clamping multiple parts in the 5-Axis Vise increases the spindle running times of the machine tool.



The center jaw can also be mounted to the Makro·Grip® 5-Axis Vise for RoboTrex automation. This increases the capacity of the automation system significantly.

Transform your Makro·Grip® 5-Axis Vise into a Dual Clamping Vise



Unscrew the Makro·Grip® jaws from the base using a hexagon wrench (internal 5 mm).



Flip base and remove the two screws.



Remove spindle and center piece.



Insert center jaw and spindle and tighten the screws on the bottom side.



Assemble the Makro·Grip® jaws back onto the base. You are now able to use your Makro·Grip® 5-Axis Vise as a dual vise.

Makro-Grip® 5-Axis Vise 77 Center Jaw and Spindle

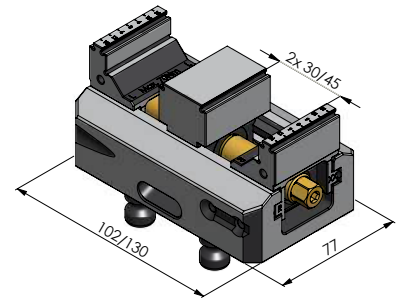
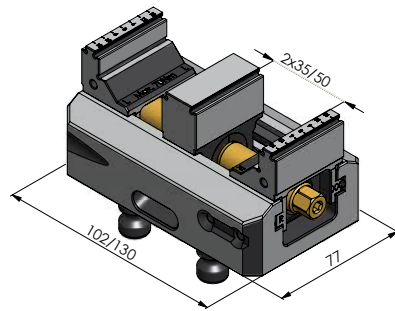

CENTER JAW AND SPINDLE FOR MAKRO-GRIP® 5-AXIS VISE 77, JAW WIDTH 46 MM

ITEM NO.	FOR MAKRO-GRIP®	CENTER JAW WIDTH	SPINDLE LENGTH	CLAMPING RANGE
48085-TG4617	48085-46	17 mm	100 mm	2 × 35 mm
48085-TG4627	48085-46	27 mm	100 mm	2 × 30 mm
48120-TG4617	48120-46	17 mm	135 mm	2 × 50 mm
48120-TG4627	48120-46	27 mm	135 mm	2 × 45 mm

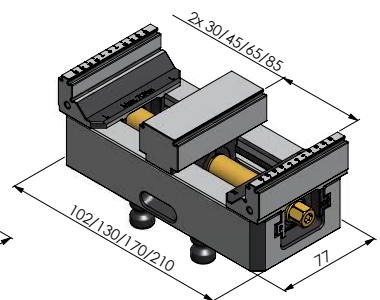
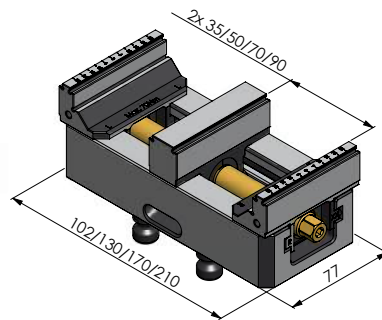

CENTER JAW AND SPINDLE FOR MAKRO-GRIP® 5-AXIS VISE 77, JAW WIDTH 77 MM

ITEM NO.	FOR MAKRO-GRIP®	CENTER JAW WIDTH	SPINDLE LENGTH	CLAMPING RANGE
48085-TG7717	48085-77	17 mm	100 mm	2 × 35 mm
48085-TG7727	48085-77	27 mm	100 mm	2 × 30 mm
48120-TG7717	48120-77	17 mm	135 mm	2 × 50 mm
48120-TG7727	48120-77	27 mm	135 mm	2 × 45 mm
48160-TG7717	48160-77	17 mm	175 mm	2 × 70 mm
48160-TG7727	48160-77	27 mm	175 mm	2 × 65 mm
48200-TG7717	48200-77	17 mm	215 mm	2 × 90 mm
48200-TG7727	48200-77	27 mm	215 mm	2 × 85 mm

Makro·Grip® 5-Axis Vise 125

Center Jaw and Spindle

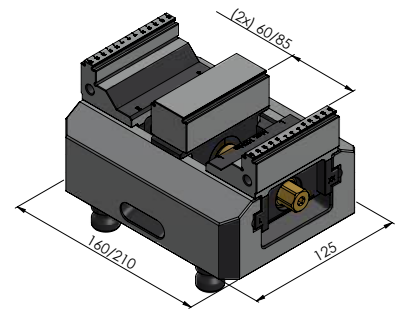
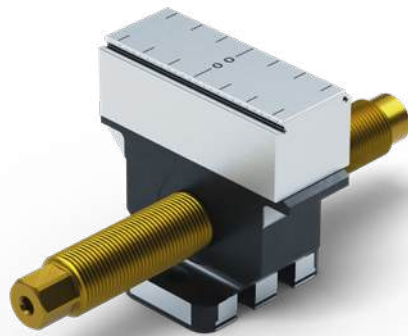

CENTER JAW AND SPINDLE FOR MAKRO·GRIP® 5-AXIS VISE 125, JAW WIDTH 77 MM

ITEM NO.	FOR MAKRO·GRIP®	CENTER JAW WIDTH	SPINDLE LENGTH	CLAMPING RANGE
48155-TG7727	48155-125	27 mm	164 mm	2 × 60 mm
48205-TG7727	48205-125	27 mm	214 mm	2 × 85 mm

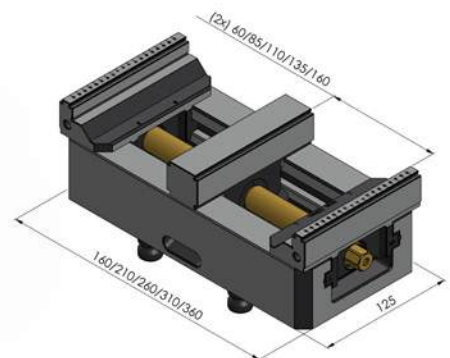
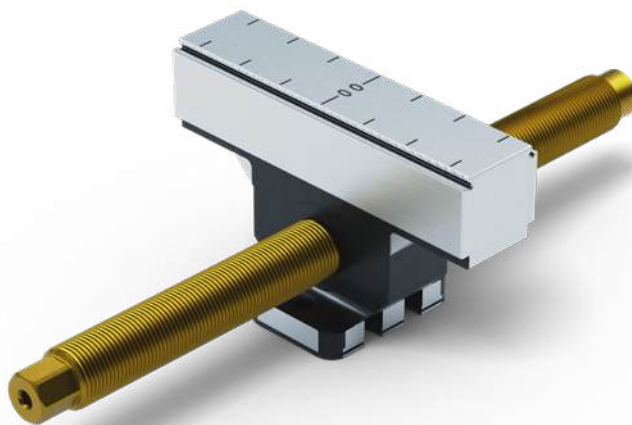

CENTER JAW AND SPINDLE FOR MAKRO·GRIP® 5-AXIS VISE 125, JAW WIDTH 125 MM

ITEM NO.	FOR MAKRO·GRIP®	CENTER JAW WIDTH	SPINDLE LENGTH	CLAMPING RANGE
48155-TG2527	48155-125	27 mm	164 mm	2 × 60 mm
48205-TG2527	48205-125	27 mm	214 mm	2 × 85 mm
48255-TG2527	48255-125	27 mm	264 mm	2 × 110 mm
48305-TG2527	48305-125	27 mm	314 mm	2 × 135 mm
48355-TG2527	48355-125	27 mm	364 mm	2 × 160 mm



MAKRO·GRIP® ULTRA



68 Makro-Grip® Ultra **Base Set**

69 Makro-Grip® Ultra **Jaws and Individual Components**

83 Makro-Grip® Ultra **Stamping Units**



**simple.
gripping.
bigger.**

Workholding in new dimensions

Makro·Grip® Ultra convinces with:

MODULARITY

PRECISION

SIMPLE OPERATION

The quite new product line Makro·Grip® Ultra offers various clamping possibilities and can be changed quickly and easily at the same time. Thanks to the expandability of its modules Makro·Grip® Ultra is capable of clamping parts of 810 mm length and beyond safely. With its size it pushes the LANG workholding to new heights. Different system heights, individually expandable clamping ranges, interchangeable clamping jaw types and useful accessories – Through its wide range of possible configurations Makro·Grip® Ultra covers any imaginable clamping application and is particularly suited for mould making and clamping flat and large components.

Benefits of Makro·Grip® Ultra:



Set-up and changeover within seconds



Low-vibration and distortion-free clamping



Clamping of asymmetrical parts



All-around machining without changing over the clamping system



Integration of automated machining processes without removing the clamping system



Simple cleaning and maintenance

The clamping system at a glance

1 Makro-Grip® Ultra Clamping Jaw

The Makro-Grip® Ultra clamping jaw which is made from solid material is available in two different types (jaw width 125 mm), either with a clamping depth of 3 mm or 5 mm. The clamping jaw has the same serration as regular Makro-Grip® 5-Axis Vises and grips the workpiece by form-fit. This way highest holding forces can be accomplished, gently and virtually wear-free. Additionally LANG offers a hardened jaw without serration but with a plain clamping step (clamping depth 16 mm) which is making use of the Avanti dovetail technology. This means that also regular Avanti top jaws can be mounted, in order to clamp parts that are not prismatic. More information about the different jaw types can be found on pages 69 and 73.



2 Base Body

The case-hardened, robust base body with integrated zero-point interface impresses with its simplicity, however it offers some technical refinements. Available are two different lengths, each in three different heights. Clamping ranges of 410, 610 and 810 mm are realized when putting them together in different compositions. The base bodies are positioned so accurately that you almost do not notice the transition from one base to the other when sliding the clamping jaws over the rails. Thanks to the exact spindle seat an exceptionally high centering accuracy is achieved. Different centering plates mounted to the inner ends of the base bodies allow for clamping parts either centrally or, in combination with a center jaw, multiple parts can be clamped. The base bodies also have a practical snap-in function which makes it easier to locate the jaws.



5

3 Threaded Cap

Each clamping jaw is individually secured by a threaded cap and thus can be moved independently from other clamping jaws. Removing the threaded cap with a magnet allows the clamping jaw's position to be shifted quickly without actuating the spindle.

4 Spindle

The spindle (M 26×2) comes in three different lengths and is equally used for single-part and multiple clamping. For clamping ranges beyond 810 mm the spindle can be ordered as a customized solution in a longer version. The actuation torque is 170 Nm.

5 Quick-Point® Zero-Point Clamping System

The interface between Makro-Grip® Ultra and the machine table is the ultra-precise Quick-Point® zero-point clamping system. Depending on requirements and workpiece size, its 96 mm grid allows supplementary base bodies to be placed next to each other and connected with each other.





Raw Part Clamping with serrated Makro-Grip® Ultra jaws

The Makro-Grip® stamping and workholding technology, which has been tried and tested for years, also shows its unique advantages in the clamping of large parts. Moulds, plates and all kinds of components from 40 to 810 mm in length and beyond are pre-stamped and then held by form-fit in the Makro-Grip® clamping jaws at only 3 or 5 mm clamping depth. The workpiece is held reliably with the highest holding forces at relatively low actuation torque, which leads to precise results, especially for deformation-sensitive and flat material.

Clamping long components across several Makro-Grip® Ultra units

Not only nearly unlimited in clamping range, but also highly adaptable and modular. Makro-Grip® Ultra can be assembled flexibly using a variety of clamping jaws, base bodies and spindles. The modularity and high centering accuracy of the Makro-Grip® Ultra clamping elements, coupled with the precision and flexibility of the Quick-Point® zero-point clamping system, guarantee ideal clamping of long parts.



Image: ifm electronic gmbh

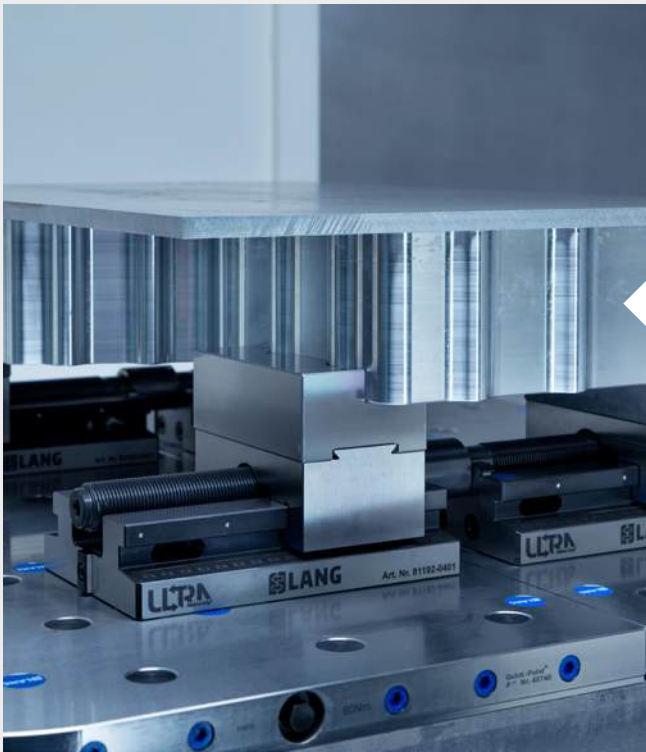

2nd operation / rear-face machining using contour jaws

Even with geometrically unshaped components, Makro-Grip® Ultra offers a simple but efficient solution: Since the jaws are independently adjustable towards the center, asymmetrical clamping configurations can be realised quickly and easily. This reduces set-up for the second operation to a minimum. The quick and precise adjustment of the jaws is ensured by a removable threaded cap and a scale on the base body.

Large plate clamping on the Quick-Tower tombstone

Makro-Grip® Ultra is not only a highly efficient clamping option for 3- and 5-axis machines, but also offers a low-build clamping system when used on horizontal machines and thus optimized accessibility when machining plates and large components. Thanks to the integrated Quick-Point® clamping studs, the vises can be quickly mounted with high repeatability or removed from tombstones which are equipped with zero-point plates.





Modularity

The modularity and small number of components, as well as the consistent Quick·Point® 96 zero-point grid allow to change the clamping setup immediately. Adding base bodies to increase the clamping range, a complete exchange of base bodies to alter the system height and changing jaw types can be done in a few simple steps without special tools.



Easy setting and cleaning

Just as quickly as it is set up, Makro·Grip® Ultra can be disassembled. Clamping jaws and spindles are removed easily which simplifies cleaning and maintenance after and in between machining processes. Clamping tasks that are performed with other fixtures are possible even without having to remove the Makro·Grip® Ultra system. Accessibility still remains and the risk of swarf clogging is low.



Quick jaw adjustment

By removing the threaded cap with a magnetic handle the position of the clamping jaws can be changed in no time without actuating the spindle. Despite their high accuracy of fit the clamping jaws glide smoothly over the guide surface. The threaded cap is kept in place by two extremely resilient hexagon screws (5 mm) which are opened/locked with half a turn.



Scale and snap-in function

For a quick adjustment into the desired position the clamping jaws feature an integrated snap-in function as an orientation aid where the operator feel resistance every 48 mm. Each base body also has a scale which provides a visual aid when positioning the clamping jaws.

Makro·Grip® Ultra Base Set



BASE SET

ITEM NO.	DESCRIPTION	HEIGHT	SPINDLE LENGTH	CLAMPING RANGE	WEIGHT
81400	Base Set 410 S	45 mm	441 mm	40 – 410 mm	12.8 kg
81415	Base Set 410 M	109 mm	441 mm	40 – 410 mm	26.0 kg
81423	Base Set 410 L	189 mm	441 mm	40 – 410 mm	43.2 kg
81600	Base Set 610 S	45 mm	617 mm	40 – 610 mm	19.1 kg
81615	Base Set 610 M	109 mm	617 mm	40 – 610 mm	40.1 kg
81623	Base Set 610 L	189 mm	617 mm	40 – 610 mm	66.9 kg
81800	Base Set 810 S	45 mm	825 mm	40 – 810 mm	25.3 kg
81815	Base Set 810 M	109 mm	825 mm	40 – 810 mm	51.7 kg
81823	Base Set 810 L	189 mm	825 mm	40 – 810 mm	85.7 kg

The model shown has the item no. 81415.

A Base Set consists of the base body and the following components:



1x Spindle Unit
Item No. 81004 / 81006 / 81008



2x Centering Plates
Item No. 81010



Quick-Point® Clamping Studs
Item No. 45570



1x Quick-Point® Cover Plug Remover
Item No. 45000-30



1x Wrench Internal Hexagon size 5 mm
Item No. 45505



1x Wrench External Hexagon size 19 mm
Item No. 45519

Additionally included in the Base Sets 610 and 810:



2 x Connection Plates
Item No. 81015

Clamping Jaws for Base Sets

Depending on requirements, either clamping jaws with the Makro-Grip® serration or base jaws with the Avanti technology can be used on the Makro-Grip® Ultra Base Set. Various types of top jaws are also available for the base jaws, which can be found on page 71. Both clamping and base jaws each require a threaded cap with which they are secured on the threaded spindle.

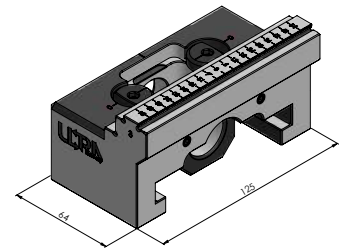
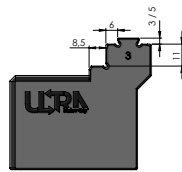

MAKRO-GRIP® ULTRA 125, SERRATED CLAMPING JAW, STEEL (HARDENED)

ITEM NO.	CLAMPING DEPTH	CLAMPING BY	WEIGHT
81483	3 mm	form-fit	2.2 kg
81485	5 mm	form-fit	2.2 kg

Selling unit: 1 piece. For each clamping unit 2 pieces are required.
The specified weight relates to 1 piece.

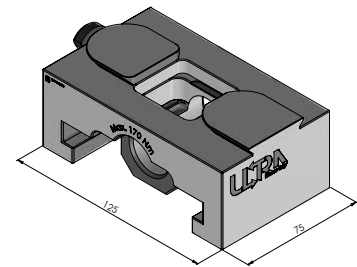

BASE JAW AVANTI 125, STEEL (HARDENED)

ITEM NO.	APPLICATION	WEIGHT
81440	As a base for regular Avanti top jaws and Avanti top jaws with plain clamping step	2.2 kg

Selling unit: 1 piece. The specified weight relates to 1 piece.
The specified weight relates to 1 piece. Suitable top jaws can be found on page 71.



THREADED CAP

ITEM NO.	DESCRIPTION	WEIGHT	QUANTITY
81080	Threaded cap, right	0.2 kg	1 piece
81090	Threaded cap, left	0.2 kg	1 piece

For each clamping unit 1 left and 1 right threaded cap is required.

NEW

Makro·Grip® Ultra Base Plates

If it is not absolutely necessary to remove the Makro·Grip® Ultra clamping system from the machine table and thus use a zero-point clamping system, Makro·Grip® Ultra can also be used without it. For this purpose, base plates made of non-hardened steel are available, which are attached to the Makro·Grip® Ultra base plates from below using M 10 cylinder head screws and firmly mounted on the machine table. By their fixation in the grooves of the machine table, the base plates can be flexibly moved in the x-direction, allowing the distance to an neighboring clamping unit to be reduced or increased.



MAKRO·GRIP® ULTRA BASE PLATE 410

Tip: Can also be used for other LANG vises with base body width 125 mm or zero-point spacing 96 mm!

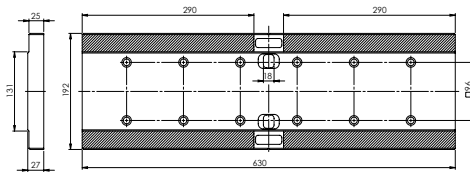

ITEM NO.	FOR BASE SETS	DIMENSIONS	WEIGHT
81411	81400, 81415, 81423	430 x 192 x 27 mm	17.1 kg

Scope of delivery: 1x Base Plate, 8x bushings, 8x cylinder head screws M 10 x 30.



MAKRO·GRIP® ULTRA BASE PLATE 610

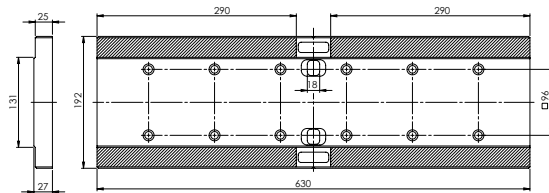

ITEM NO.	FOR BASE SETS	DIMENSIONS	WEIGHT
81611	81600, 81615, 81623	630 x 192 x 27 mm	25.0 kg

Scope of delivery: 2x Base Plates, 1x Connection Set, 12x bushings, 12x cylinder head screws M 10 x 30.



MAKRO·GRIP® ULTRA BASE PLATE 810

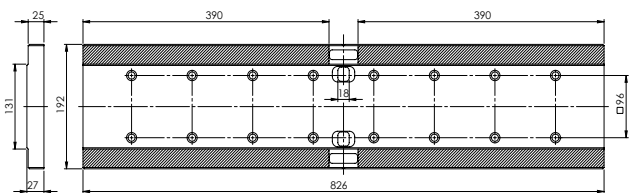

ITEM NO.	FOR BASE SETS	DIMENSIONS	WEIGHT
81811	81800, 81815, 81823	826 x 192 x 27 mm	32.9 kg

Scope of delivery: 2x Base Plates, 1x Connection Set, 16x bushings, 16x cylinder head screws M 10 x 30.

Top Jaws for Makro·Grip® Ultra Base Jaws

The top jaws shown are used in combination with the base jaws (item no. 81440) on page 69. They are used for smooth clamping of cubic components, of profiles and molds (single or multiple in each case).

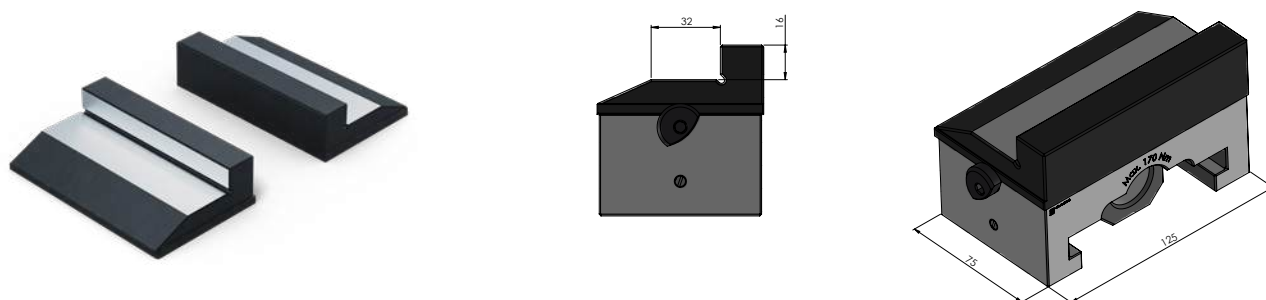

AVANTI 125 TOP JAW WITH PLAIN CLAMPING STEP, STEEL (HARDENED)

ITEM NO.	CLAMPING DEPTH	CLAMPING BY	WEIGHT
81450	16 mm	friction	2.4 kg

Selling unit: 1 pair. The specified weight relates to 1 pair.

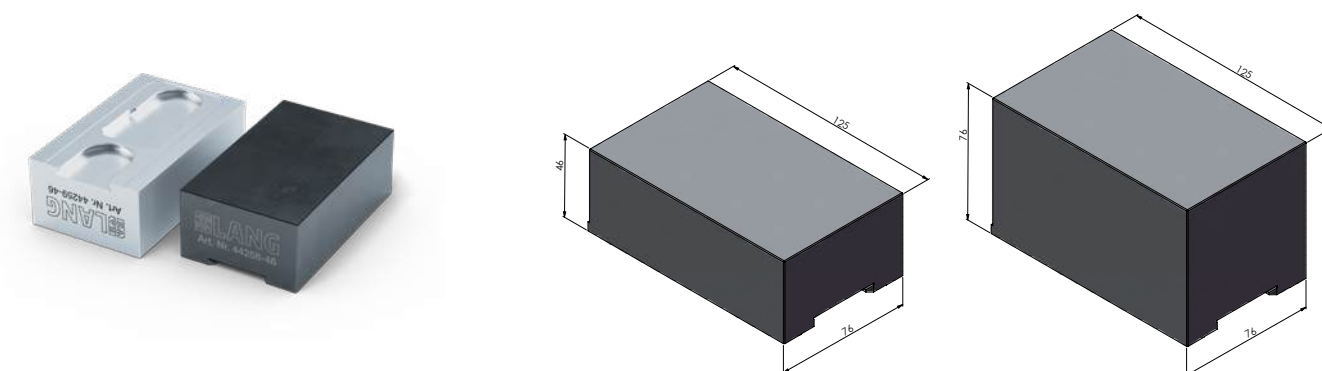

AVANTI 125 TOP JAW (SOFT)

ITEM NO.	MATERIAL	HEIGHT	WEIGHT
44258-46	Steel (16 MnCr 5)	46 mm	3.3 kg
44258-76	Steel (16 MnCr 5)	76 mm	5.5 kg
44259-46	Aluminium (F50)	46 mm	1.2 kg
44259-76	Aluminium (F50)	76 mm	2.0 kg

Selling unit: 1 piece. The specified weight relates to 1 piece.

Note: This type of top jaw is the common version for the Avanti vise.

Clamping and support options for the center

The center base jaw 125 type Avanti is used in combination with a support jaw as an additional support to reduce possible vibrations in the machining process and also as a basis for the center top jaw Avanti 125, as well as conventional Avanti top jaws. For form-fit multiple clamping, the Makro-Grip® 125 center jaw with serration is used.

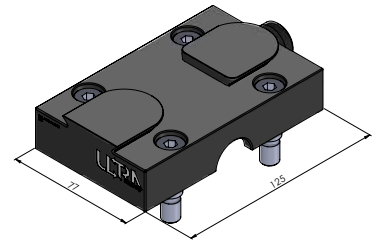

CENTER BASE JAW AVANTI 125, STEEL (HARDENED)

ITEM NO.	APPLICATION	WEIGHT
81440-TG	As a base for support jaws or Avanti top jaws	1.8 kg

Selling unit: 1 piece. The specified weight relates to 1 piece.

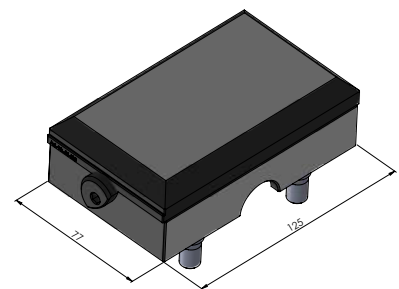
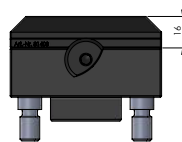

SUPPORT JAW, STEEL (SOFT)

ITEM NO.	FOR	APPLICATION	WEIGHT
81403	81483 / 81450	Single-part clamping by form-fit / friction	1.0 kg
81405	81485	Single-part clamping by form-fit / friction	0.9 kg

Selling unit: 1 piece. The specified weight relates to 1 piece.

NEW VERSION

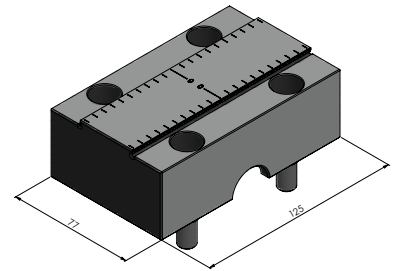
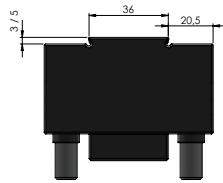

MAKRO-GRIP® ULTRA 125 SERRATED CENTER JAW, STEEL (HARDENED)

ITEM NO.	CLAMPING DEPTH	APPLICATION	WEIGHT
81483-TG	3 mm	Multiple clamping by form-fit	2.3 kg
81485-TG	5 mm	Multiple clamping by form-fit	2.3 kg

Selling unit: 1 piece. The specified weight relates to 1 piece.

The Center Jaw is screwed directly onto the base body and, depending on the variant, used with the Makro-Grip® clamping jaw with serration (item no. 81483 or 81485).

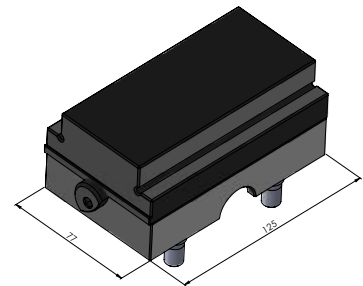
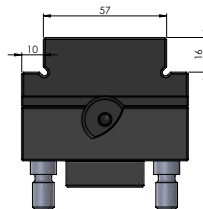

CENTER TOP JAW AVANTI 125 WITH PLAIN CLAMPING STEP, STEEL (HARDENED)

ITEM NO.	CLAMPING DEPTH	APPLICATION	WEIGHT
81450-TG	16 mm	Multiple clamping by friction	1.9 kg

Selling unit: 1 piece. The specified weight relates to 1 piece.

To be used in combination with the center base jaw 125 type Avanti (item no. 81440-TG).



Note: For multiple clamping with mounted center (base) jaw, it is necessary to replace the centering plates installed as standard in the base set with compensating centering plates (item no. 81040). Information on this can be found on p. 76.

Makro·Grip® Ultra Base Body

An individual base body is needed especially when an existing base set is to be expanded. For instance, if you want to go from a clamping range of 410 mm to 610 mm / 810 mm or beyond. With an individual base body Quick·Point® clamping studs are included (4 pcs. for long base bodies, 2 pcs. for short base bodies). Also included are a slot nut and the respective scaling. For stringing together individual base bodies, connection plates are required which can be found on page 76.



SHORT BASE, HEIGHT "S"

ITEM NO.	HEIGHT	LENGTH	WEIGHT
81011	45 mm	96 mm	2.7 kg



SHORT BASE, HEIGHT "M"

ITEM NO.	HEIGHT	LENGTH	WEIGHT
81012	109 mm	96 mm	6.6 kg



SHORT BASE, HEIGHT "L"

ITEM NO.	HEIGHT	LENGTH	WEIGHT
81013	189 mm	96 mm	11.6 kg



LONG BASE, HEIGHT "S"

ITEM NO.	HEIGHT	LENGTH	WEIGHT
81021	45 mm	192 mm	5.0 kg



LONG BASE, HEIGHT "M"

ITEM NO.	HEIGHT	LENGTH	WEIGHT
81022	109 mm	192 mm	11.9 kg



LONG BASE, HEIGHT "L"

ITEM NO.	HEIGHT	LENGTH	WEIGHT
81023	189 mm	192 mm	20.5 kg

Makro·Grip® Ultra individual components



SPINDLE

ITEM NO.	DESCRIPTION	LENGTH	WEIGHT
81004	Spindle unit 410	441 mm	1.8 kg
81006	Spindle unit 610	617 mm	2.5 kg
81008	Spindle unit 810	825 mm	3.3 kg

The spindle (M 26 × 2) comes in three different lengths and is equally used for single-part and multiple clamping. For clamping ranges beyond 810 mm the spindle can be ordered as a customized solution in a longer version. The actuation torque is 170 Nm.



CENTERING PLATE

ITEM NO.	APPLICATION	QUANTITY
81010	Single-part clamping, concentric	1 pc.
81040	Multiple clamping, compensating	1 pc.

For each clamping unit 2 centering plates of the same kind are required. They are mounted to the inner ends of the base bodies and ensure an accurate positioning of the spindle. Two different versions are available for single-part and multiple clamping. The centering plate for multiple clamping has a recess which allows to clamp workpieces with a 4 mm variance in length.



CONNECTION PLATE

ITEM NO.	DESCRIPTION	QUANTITY
81015	Connection plate	1 pc.

Connection plates are already included in delivery of Base Sets. They are used for stringing together base bodies.



PLASTIC COVERS

ITEM NO.	DESCRIPTION	QUANTITY
81500	Plastic covers for base bodies	20 pcs.

To cover the bores on the upper guide surface of the base body, if center jaws are not mounted.



WRENCHES

ITEM NO.	FOR	WRENCH SIZE
45505	Internal hexagon	5 mm
45519	External hexagon	19 mm

Wrenches for the initial clamping setting (external hexagon) and actuation of the threaded caps' screws (internal hexagon).



HEXAGON SOCKET

ITEM NO.	SQUARE DRIVE	WRENCH SIZE
45511	1/2"	19 mm

Hexagon socket for commercial torque wrenches.



QUICK-POINT® COVER PLUG REMOVER

ITEM NO.	DESCRIPTION
45000-30	Cover Plug Remover

Comfortable magnetic handle for removing threaded caps from the clamping jaws and steel plugs from the Quick-Point® plates.

Overview of the Base Set system heights with mounted clamping jaws

Base Set

System height „S“

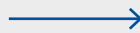
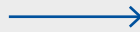

System height „M“

System height „L“



Makro·Grip® Ultra Hydro·Sup screw jack



A specific hydraulic screw jack and spacers to match the respective height of the base bodies have a supporting effect on the clamping process which is particularly important with flat and wide material.



The screw jack which is actuated by a socket wrench adapts to the workpiece with its self-aligning support and reduces vibrations, which contributes to an increased surface quality.



Hydro-Sup is mounted and fixed like any other LANG workholding device with its clamping stud to the Quick·Point® zero-point clamping system.

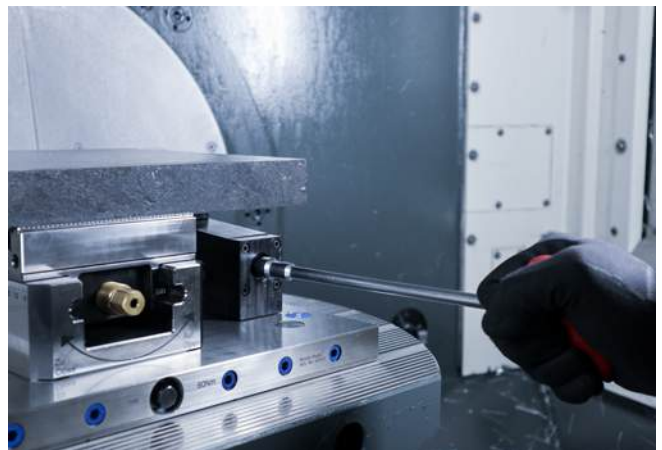

Due to its height of 86 mm the Hydro-Sup screw jack can also be used – without spacers – when clamping overhanging parts in a regular Makro·Grip® 5-Axis Vise 125.



HYDRO-SUP SCREW JACK

ITEM NO.	DESCRIPTION	RESTING HEIGHT	WEIGHT
81586	Hydro-Sup hydraulic screw jack	85 – 89 mm	2.8 kg
81515	Spacer for system height "M"	148 – 152 mm	2.9 kg
81523	Spacer for system height "L"	228 – 232 mm	6.6 kg

The hydraulic screw jack Hydro-Sup helps to minimize vibrations during the machining process of overhanging workpieces. The height of 86 mm is identical to Makro-Grip® Ultra system height "S". With the addition of spacers system heights "M" and "L" can be matched.

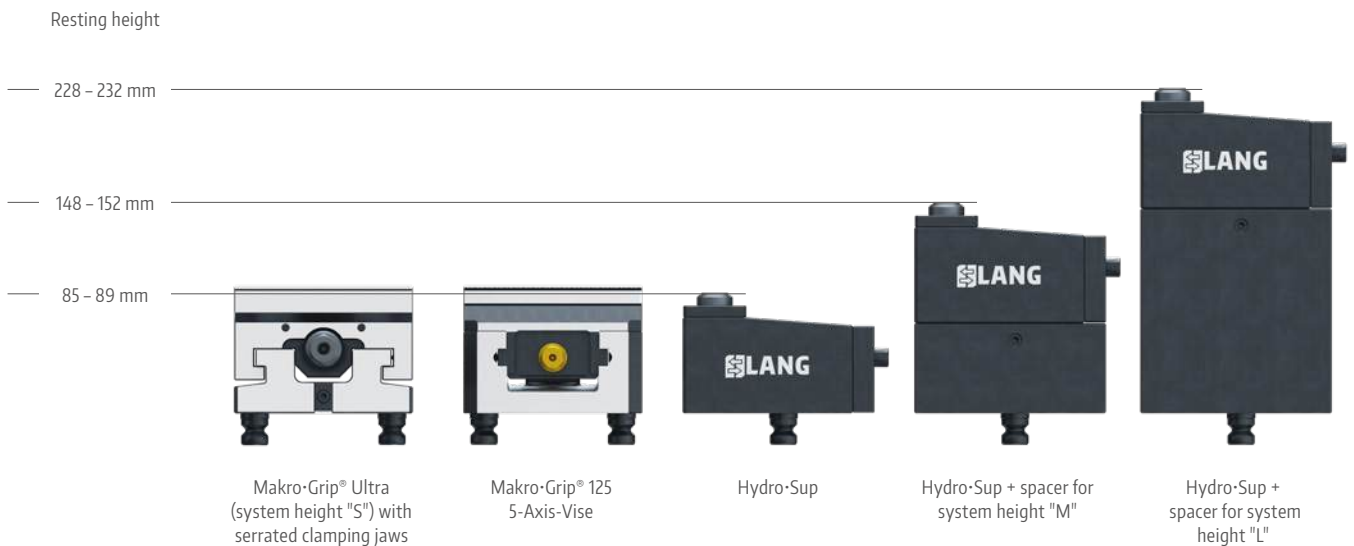

The hydraulic screw jack with its spacers is suitable for all Makro-Grip® Ultra system heights. It can also be used with regular Makro-Grip® 5-Axis-Vises 125 in order to support overhanging workpieces.



HYDRO-SUP HEXAGON WRENCH

ITEM NO.	LENGTH	WRENCH SIZE
45512	230 mm	12 mm

For actuation of the Hydro-Sup screw jack.

Makro·Grip® Ultra Stamping Unit

ORIGINAL
MAKRO·GRIP

The Stamping Technology

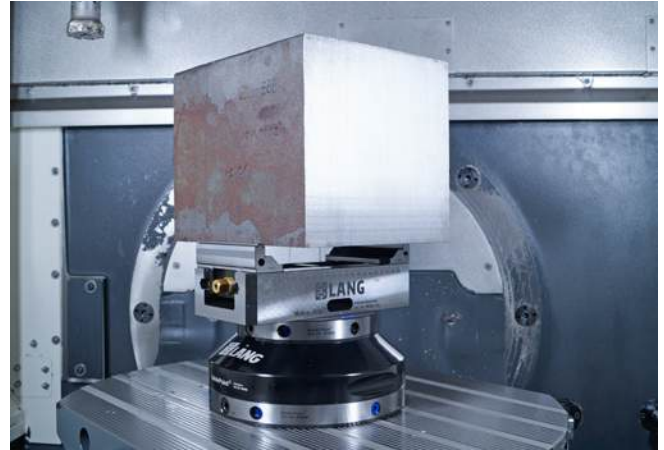
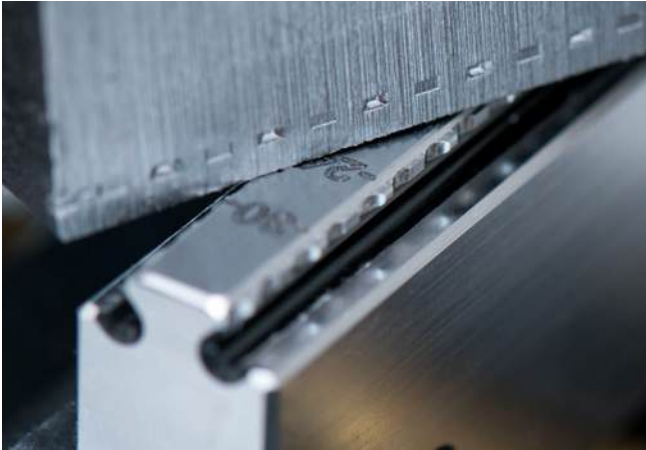

Form-Closure Technology refers to a technology in which the workpiece to be clamped is "pre-stamped" with a defined contour under high stamping pressure (up to 20 t) outside of the machine tool, before it is clamped in the clamping device. Due to the great

amount of advantages for the actual clamping process through pre-stamping the Makro·Grip® technology is considered a benchmark in the 5-sided machining of blanks and absolutely beneficial to automated manufacturing.

Why pre-stamp a workpiece?

The form-fit effect between the serration of the clamping jaws and stamping indentation guarantees highest holding forces and maximum process reliability at a very low clamping pressure. This practically eliminates any material deformation which is crucial to clamping flat and deformation-sensitive material and a key factor in achieving the desired milling quality. The stamping technology completes the Makro·Grip® Ultra system and raises the quality of plate and large part clamping to a new level.



Makro·Grip® Ultra stamping system

The Makro·Grip® Ultra stamping unit is available in two different sizes. Fundamentally they are identical, but differ in their base plate's size and number of grooves and locking holes.

The system is designed as a dual-stamping unit which can be placed flexibly in the 96 mm grid of the base plate. The stamping unit is operated conveniently via push button. Included in delivery are two different sets of parallels which match the clamping depth of the serrated Makro·Grip® Ultra clamping jaws (3 mm and 5 mm).



MAKRO·GRIP® ULTRA STAMPING UNIT

ITEM NO.	STAMPING JAW TYPE	BASE PLATE	MAX. STAMPING RANGE
83420-HE	High-End	680 × 612 mm	420 mm
83810-HE	High-End	1080 × 996 mm	810 mm

- Scope of delivery:
- Frame with base plate
 - 2 stamping units
 - 2 pairs of stamping jaws
 - 2 pairs of each parallel type (3 mm + 5 mm)
 - Pneumatic-hydraulic power multiplier (1 - 360 bar)
 - Scaled endstops and protection shields
 - Push button for operation by hand
 - Gauging blocks for measuring the wear of the serration



MAKRO·GRIP® STAMPING JAWS

ITEM NO.	TYPE	FOR MATERIALS	QUANTITY
41112-06	High-End	up to 45 HRC	1 pair

Note: Stamping jaws are sold without parallels. These must be ordered separately.



MAKRO·GRIP® STAMPING JAW PARALLELS

ITEM NO.	CLAMPING DEPTH	QUANTITY
41111-0308	3 mm	1 pair
41111-0508	5 mm	1 pair

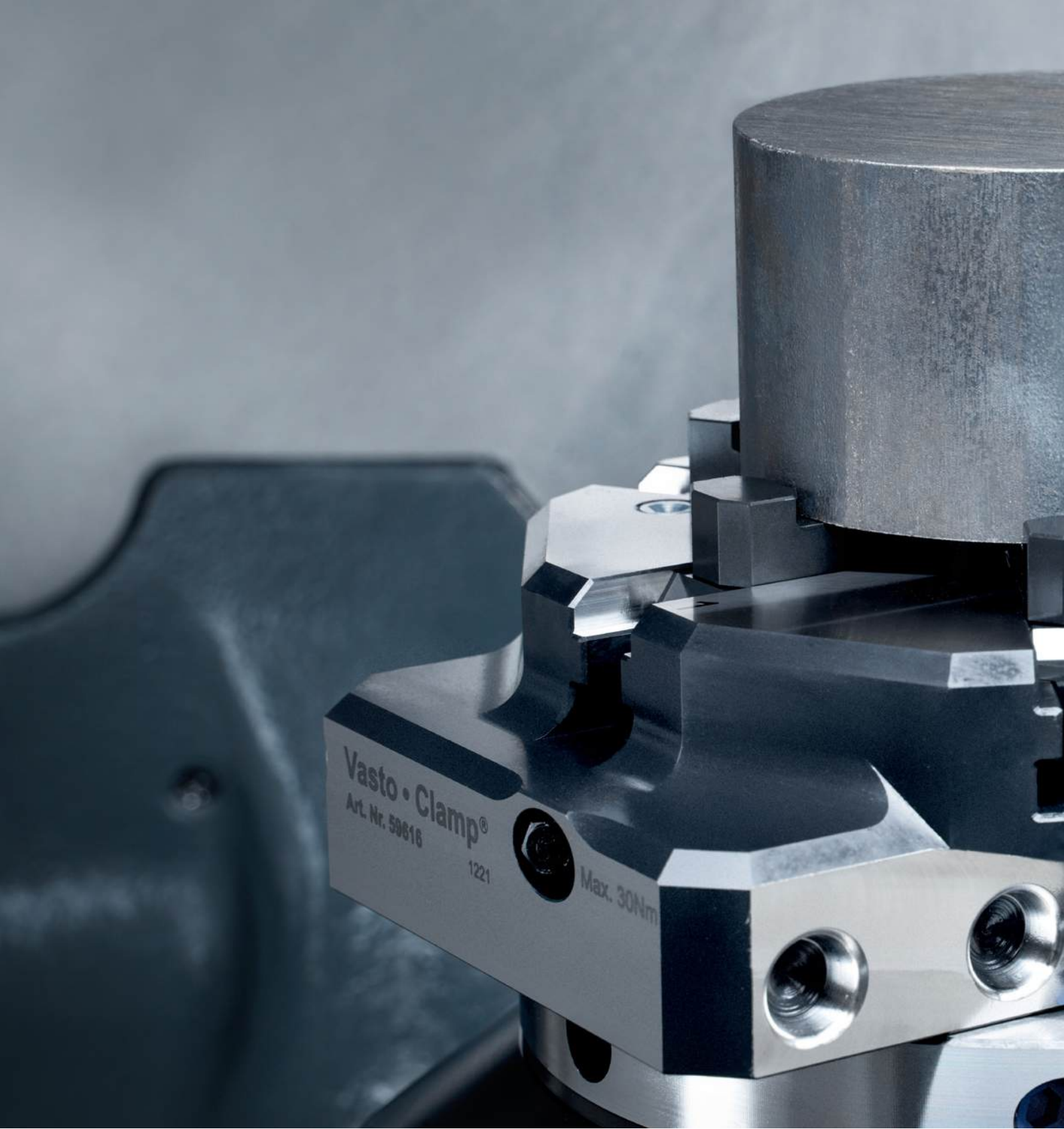

Vasto-Clamp®
Art. Nr. 59616

1221

Max. 30Nm

CONVENTIONAL WORKHOLDING

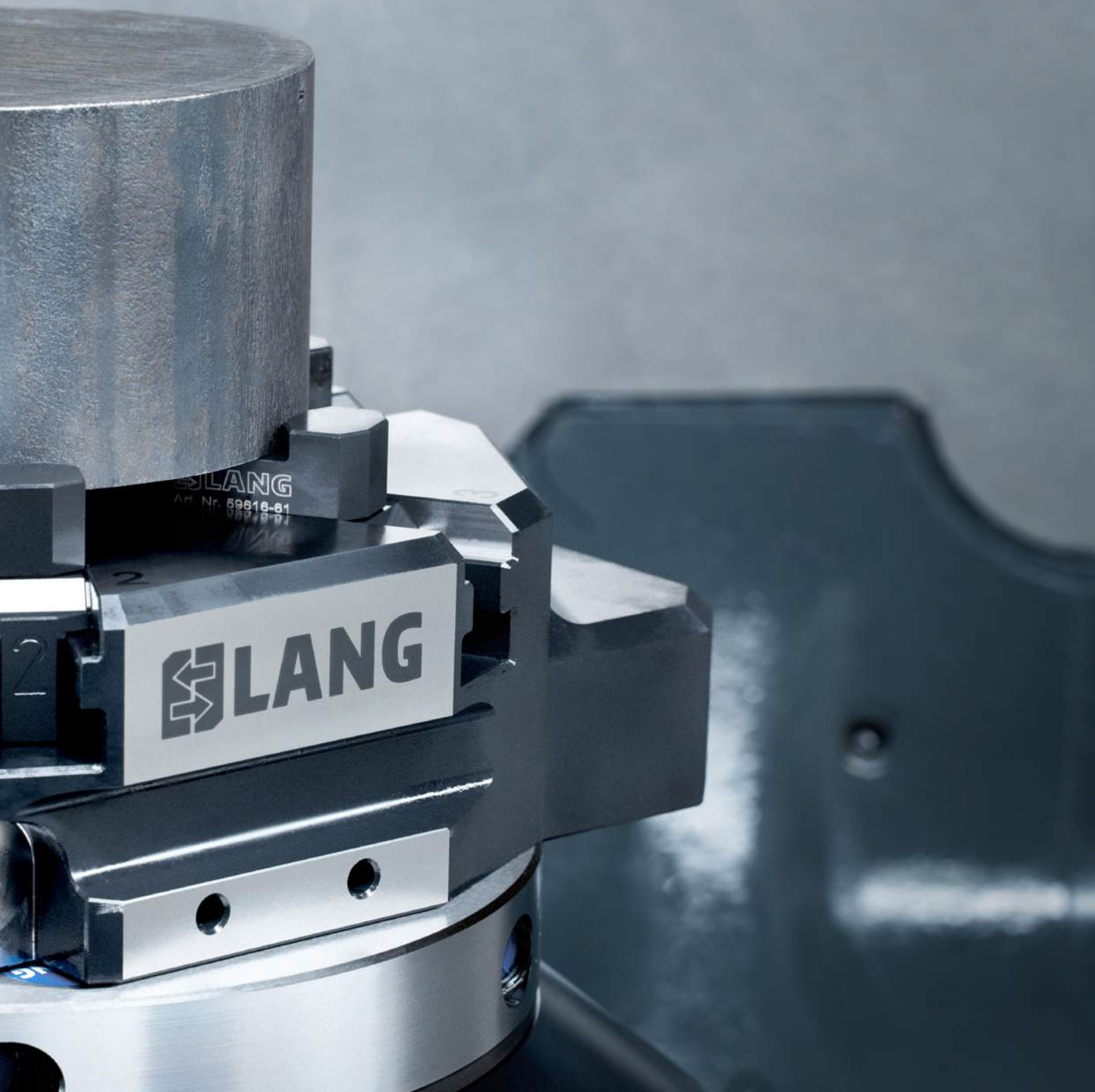

88 Vasto·Clamp **6-jaw Chuck**

96 Avanti **Profile Clamping**

98 Avanti 77

102 Avanti 125

104 Profilo **Profile Clamping**

106 Profilo 77

108 Profilo 125

110 Vario·Tec **Support and Resting System**

112 Vario·Tec 77

114 Vario·Tec 125

116 Preci·Point **Collet Chuck**



simple.
versatile.
clamping.

Diverse clamping solutions for milling round or pre-machined components

Conventional Workholding solutions by LANG are characterized by:

FLEXIBILITY

VERSATILITY

SET-UP TIME SAVINGS

While the strengths of Makro-Grip® stamping technology and the 5-Axis Vises are mainly seen in the processing of unmachined parts, workholding devices of the „Conventional Workholding“ category offer various options for smooth clamping of round or pre-machined components. To solve the respective clamping task, a 6-jaw chuck, two collet chucks and a total of three different types of centering vises are available to the operator. The vises differ only in the type of their clamping jaws. They use the same base body as the Makro-Grip® 5-Axis Vise, which ensures consistent compatibility and interchangeability. The different types of jaws of the „Conventional Workholding“ are ideally suited for demanding rear-face machining tasks and perfectly complement the 5-Axis Vise in order to machine all faces of a workpiece.

Benefits of Conventional Workholding solutions:



Minimal time required for set-up



Simple and user-friendly operation



Enormous flexibility due to the possibility of using different top jaws



Diverse clamping solutions for differently shaped parts



All centering vise jaw types compatible with the Makro-Grip® 5-Axis Vises



Precise and robust mounting between base and top jaws

Vasto-Clamp Technology

The versatile 6-jaw chuck with quick exchange system

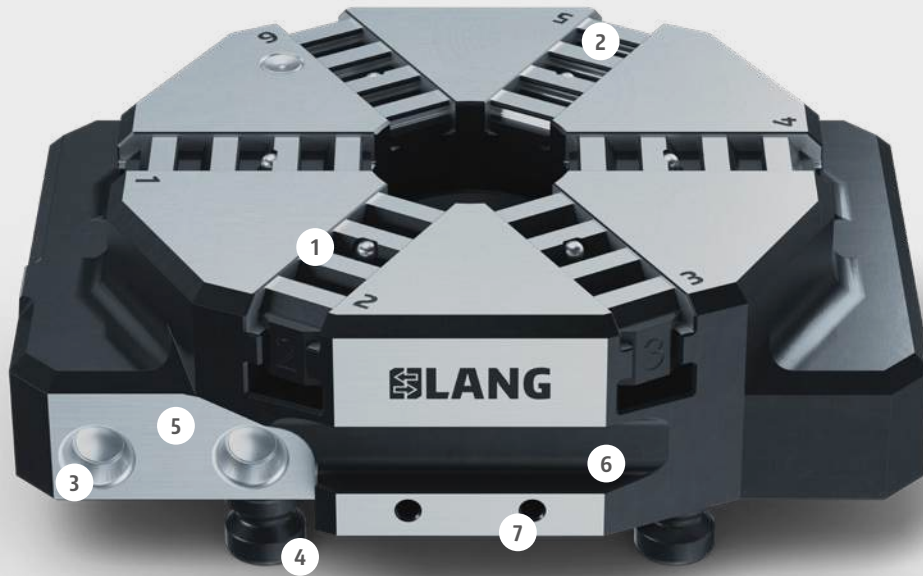

- 1 Innovative click mechanism ensures quick jaw exchange
- 2 Different jaw types offer various application possibilities
- 3 Gripper interface allows utilization in the RoboTrex 96 automation system
- 4 Integrated Quick-Point® zero-point interface
- 5 Robust steel base for maximum durability
- 6 Recess for an ergonomic handling
- 7 Swarf and coolant drain



Vasto-Clamp 6-jaw chuck with 6 soft top jaws



Vasto-Clamp 6-jaw chuck with 3 hardened gripping jaws

Innovative jaw exchange without tools

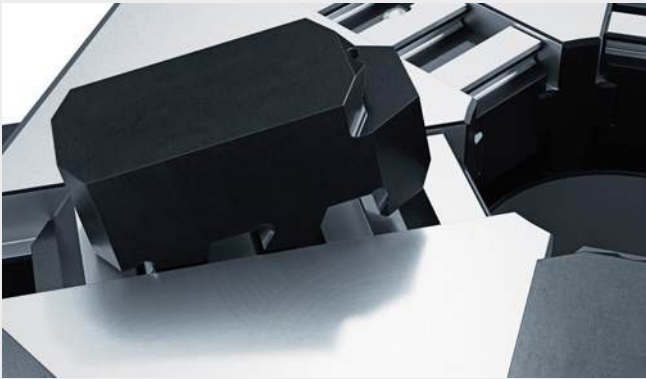

Without the use of any tools, the top jaws are locked into the base jaws (directional movement from the inside to the outside).

The Vasto-Clamp 6-jaw chuck with quick-jaw exchange system is equally suited for machining blanks as well as for contour clamping of deformation-sensitive components. Depending on the application, the user can choose between hardened gripping jaws and soft top jaws. In both cases the hand-operated spiral chuck uses a clamping principle by friction. The top jaws are fastened completely



A spring-loaded ball bearing ensures a firm fit of the top jaw.

without additional tools via an innovative click mechanism, which ensures an extremely robust and resilient jaw fit. The jaw chuck is equipped with an integrated zero-point mounting and automation interface for RoboTrex and can be used for both outer diameter and, with special jaws, for inner diameter clamping.

Applications



Image: CNC-Technik Ortlieb GmbH & Co. KG

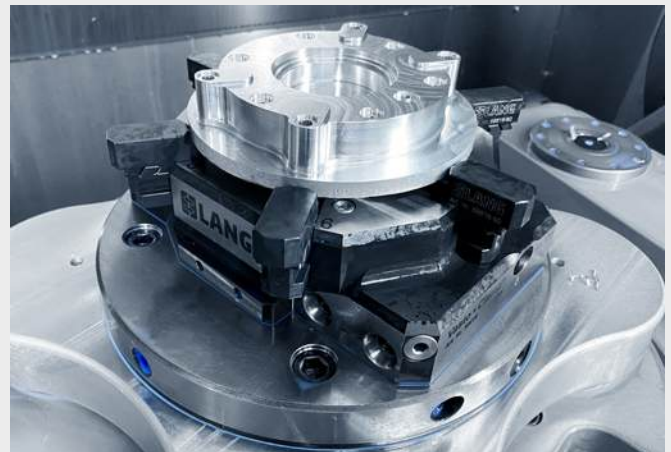

Image: Dengler CNC-Technik



Vasto-Clamp 6-Jaw Chuck



VASTO-CLAMP 6-JAW CHUCK

ITEM NO.	DIMENSIONS	CLAMPING RANGE	WEIGHT
59616	210 × 155 × 57 mm	10 – 160 mm	9.6 kg

Included in delivery: Base jaws for O.D. clamping, hexagonal insert with drive square 1/4", size 8 mm

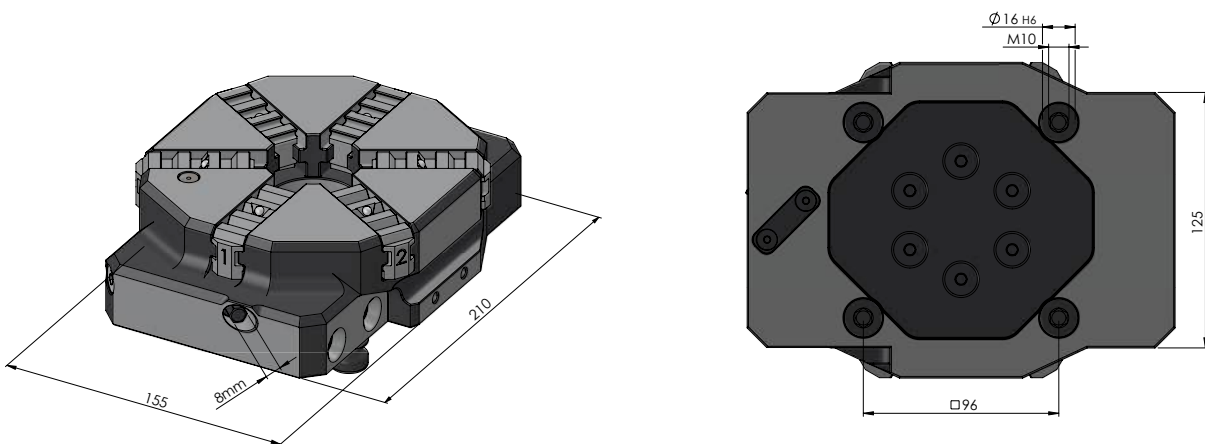

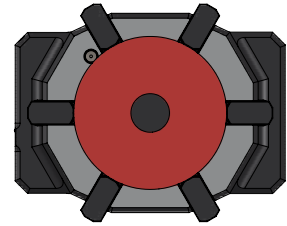
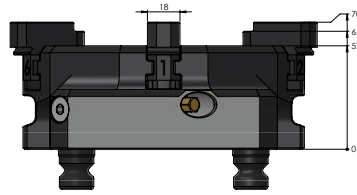

VASTO-CLAMP GRIPPING JAWS (HARDENED)

ITEM NO.	MATERIAL	CLAMPING RANGE	QUANTITY
59616-60	Steel (16 MnCr 5)	30 - 120 mm	6 pcs.

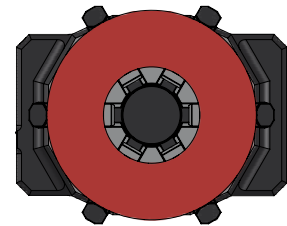
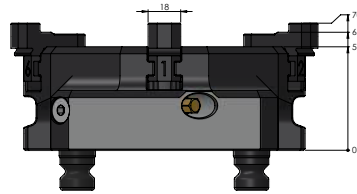

VASTO-CLAMP GRIPPING JAWS (HARDENED)

ITEM NO.	MATERIAL	CLAMPING RANGE	QUANTITY
59616-61	Steel (16 MnCr 5)	75 - 160 mm	6 pcs.

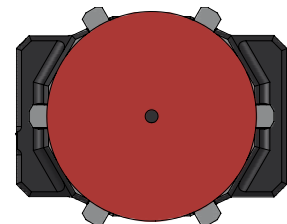
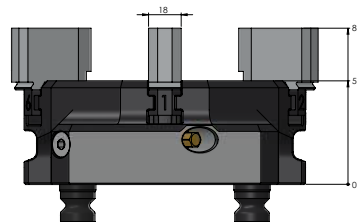

VASTO-CLAMP TOP JAWS, SOFT

ITEM NO.	MATERIAL	CLAMPING RANGE	QUANTITY
59616-62	Steel (16 MnCr 5)	10 - 160 mm	6 pcs.
59616-63	Aluminium (F 50)	10 - 160 mm	6 pcs.

NEW

Vasto-Clamp Gripping and Top Jaws for inner diameter clamping

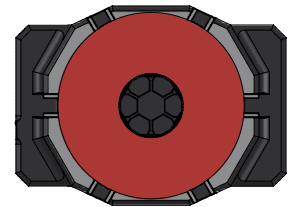
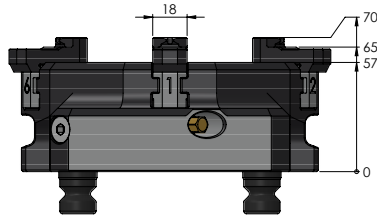

VASTO-CLAMP GRIPPING JAWS FOR I.D. CLAMPING (HARDENED)

ITEM NO.	MATERIAL	CLAMPING RANGE	QUANTITY
59616-70	Steel (16 MnCr 5)	50 - 145 mm	6 pcs.

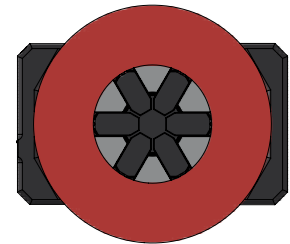
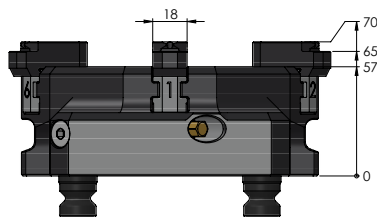

VASTO-CLAMP GRIPPING JAWS FOR I.D. CLAMPING (HARDENED)

ITEM NO.	MATERIAL	CLAMPING RANGE	QUANTITY
59616-71	Steel (16 MnCr 5)	90 - 185 mm	6 pcs.

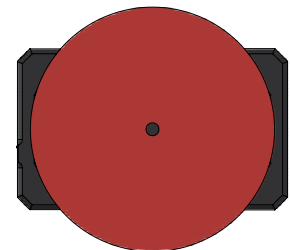
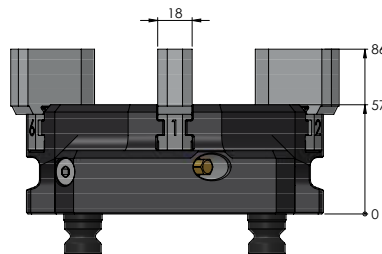

VASTO-CLAMP TOP JAWS FOR I.D. CLAMPING (HARDENED)

ITEM NO.	MATERIAL	CLAMPING RANGE	QUANTITY
59616-72	Steel (16 MnCr 5)	10 - 190 mm	6 pcs.
59616-73	Aluminium (F 50)	10 - 190 mm	6 pcs.

NEW

Vasto-Clamp Base Jaws for inner diameter clamping



VASTO-CLAMP BASE JAWS FOR I.D. CLAMPING

ITEM NO.	MATERIAL	FOR	QUANTITY
59616-30	Steel (16 MnCr 5)	59616-70 to 59616-73	6 pcs.



Vasto-Clamp with 6 hardened gripping jaws for I.D. clamping.

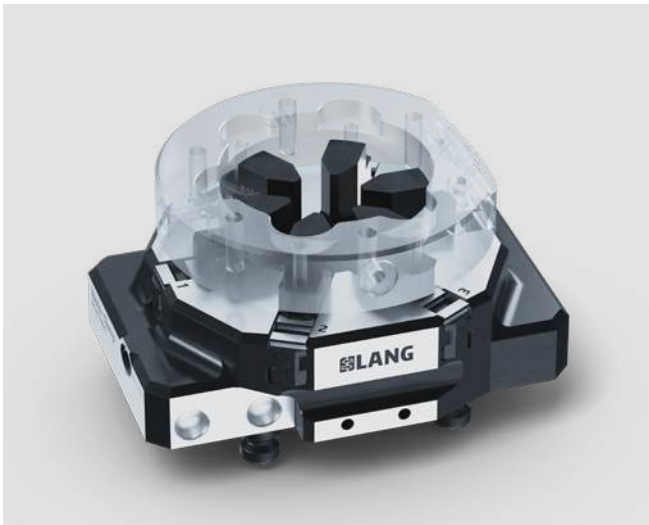

Vasto-Clamp with 6 soft top jaws for I.D. clamping.

Avanti and Profilo – Different strengths, different purposes

The two vise types Profilo and Avanti serve a similar purpose – namely the clamping of round and pre-machined parts – but have different strengths.

If set-up times are important and operators have to change between different jaw types consistently, the Avanti is clearly the right choice. Thanks to extremely low purchasing costs, there is no need to manufacture Avanti top jaws in-house or spend additional

machine capacities for their preparation. The Profilo, on the other hand, impresses with its flexibility and the possibility of using self-made top jaws or fixtures on the vise.

Both vise types use an interchangeable jaw system and can be converted into multiple clamping vise by adding center jaws. By default, the top jaws are available in aluminum and steel, but are mounted differently, which is described below.

Profilo and Avanti – a head-to-head comparison:

PROFILO	VS.	AVANTI
Highly flexible due to self-made top jaws	SPECIALTY	Quick changeover
no / yes / yes	FOR JAW WIDTH 46 / 77 / 125	yes / yes / yes
Yes	IN-HOUSE MANUFACTURING OF TOP JAWS POSSIBLE	No
No	TOP JAWS AVAILABLE IN DIFFERENT HEIGHTS	Yes
Yes	CUSTOMIZED TOP JAWS UPON REQUEST	Yes
No	QUICK RELEASE FASTENER	Yes
Feather keys	POSITIONING	Dovetail
4 cylinder head screws per jaw, mounted from the top or bottom	MOUNTING	Lateral force by tightening one screw and pull-down effect by dovetail

Avanti Profile Clamping Vise

The universal vise with great handling characteristics and extremely fast jaw exchange.

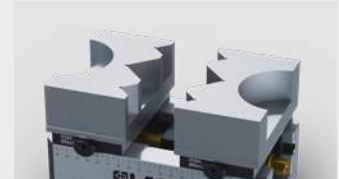
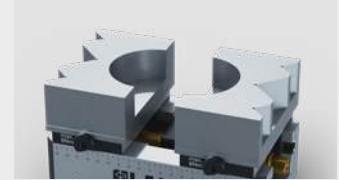

Large-volume steel or aluminium top jaws are available in different heights. They are clamped from the outside with just one screw allowing the complete block to be used for contours.

Profilo Profile Clamping Vise

The flexible clamping system for self-made top jaws or fixtures.



Just like the Avanti, the Profilo top jaws are available in aluminium and steel. The large-volume blocks allow contours to be added on both sides of the jaws.

Avanti Technology

The universal vise with great handling characteristics and unbeatably quick set-up time.

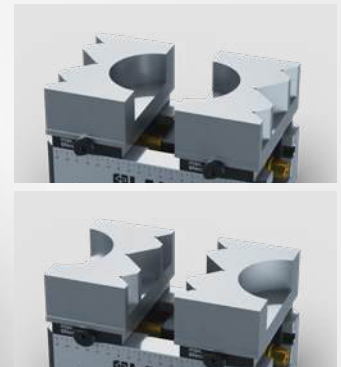

Large-volume steel or aluminium top jaws are available in different heights. They are clamped from the outside with just one screw allowing the complete block to be used for contours.

- 1 Precise positioning of jaws thanks to patented clamping interface
- 2 Centering accuracy ± 0.02 mm
- 3 Double guided jaws
- 4 Integrated with clamping studs for precise clamping in the Quick-Point® zero-point clamping system
- 5 Top jaws available in steel or aluminium
- 6 Quick jaw exchange with only one screw (internal hexagon 5 mm)
- 7 Rigid and sturdy base – but still lightweight and handy

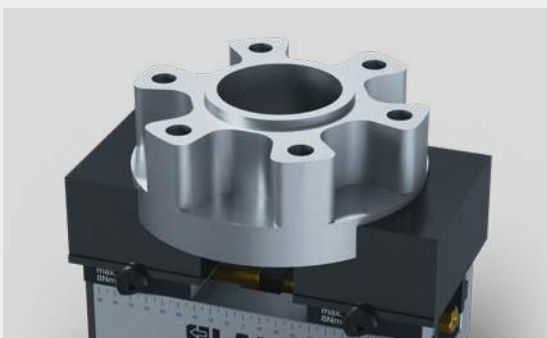

If the maximum clamping diameter ($\varnothing 34$ mm) of the Preci-Point Collet Chuck is not enough, the Avanti vise is a great choice to clamp round stock with a larger diameter.

Avanti Quick Jaw Exchange System applications

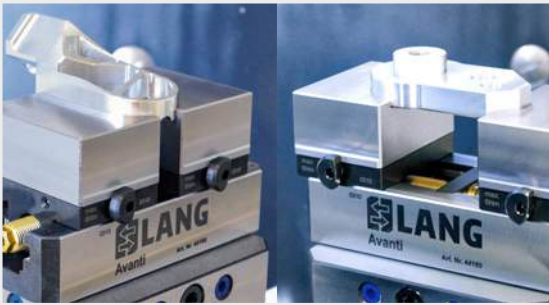

Independent from the alignment of the workpiece a great variety of profiles can be clamped for best accessibility with the patented quick jaw exchange system. By adding contours on both sides of the jaws and through their maximum usable volume top jaws can be used twice.



How to prepare top jaws:

To get the best possible result when machining with the Avanti, we recommend simulating the future clamping situation as accurately as possible.

We suggest clamping a precision block at maximum torque between the top jaws while machining the workpiece contour into the top jaws.

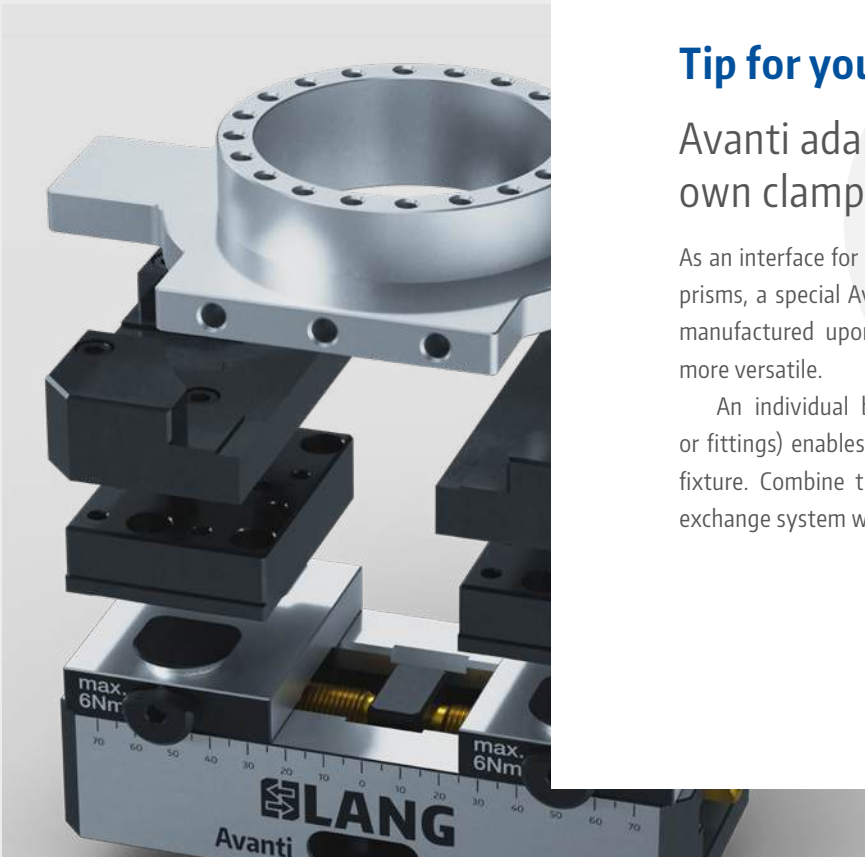

Tip for your benefit:

Avanti adaptor jaw to use own clamping fixtures

As an interface for customized clamping fixtures such as prisms, a special Avanti adaptor jaw can be offered and manufactured upon request, making the system even more versatile.

An individual borehole pattern (e.g. tapped holes or fittings) enables a simple assembly of your clamping fixture. Combine the benefits of the Avanti quick jaw exchange system with your own fixtures!

Avanti 77



AVANTI 77, JAW WIDTH 46 MM

ITEM NO.	BASE LENGTH	MAX. CLAMPING RANGE	WEIGHT	COMPARABLE PREVIOUS VERSION
44085-46	102 mm	97 mm	2.2 kg	44065
44120-46*	130 mm	125 mm	2.6 kg	44105

* automatable

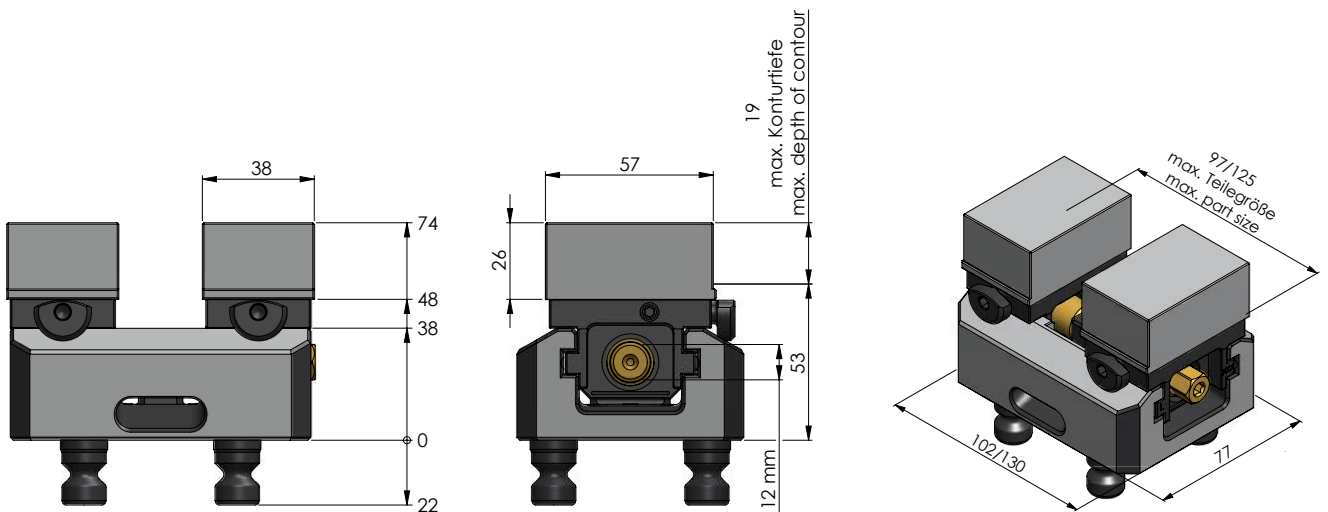



AVANTI 77 BASE JAWS, JAW WIDTH 46 MM

ITEM NO.	DIMENSIONS	WEIGHT	UNIT	COMPARABLE PREVIOUS VERSION
44771-46	55 × 36 mm	0.6 kg	1 pair	44461

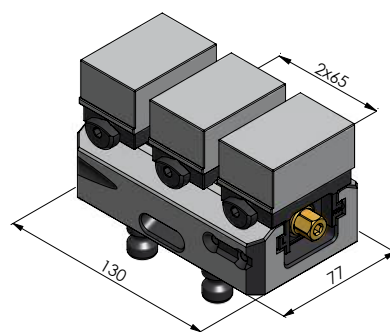
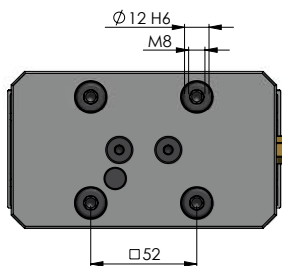

CENTER BASE JAW + SPINDLE FOR AVANTI 77, JAW WIDTH 46 MM

ITEM NO.	SPINDLE LENGTH (+ \varnothing)	FOR AVANTI	WEIGHT
44120-TG46	135 mm ($\varnothing 16$ mm)	44120-46	0.5 kg



AVANTI 46 TOP JAWS, SOFT

ITEM NO.	MATERIAL	DIMENSIONS	WEIGHT	UNIT
44468-26	Steel (16MnCr5)	57 × 38 × 26 mm	0.4 kg	1 pc.
44469-26	Aluminium (F50)	57 × 38 × 26 mm	0.1 kg	1 pc.

Top jaws fit the new base jaw version and also the previous one.

Avanti 77

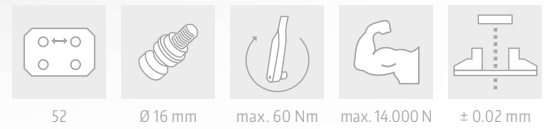

AVANTI 77, JAW WIDTH 77 MM

ITEM NO.	BASE LENGTH	MAX. CLAMPING RANGE	WEIGHT	COMPARABLE PREVIOUS VERSION
44120-77*	130 mm	125 mm	3.5 kg	44120
44160-77	170 mm	165 mm	4.2 kg	44160
44200-77	210 mm	205 mm	4.8 kg	44200

*automatable

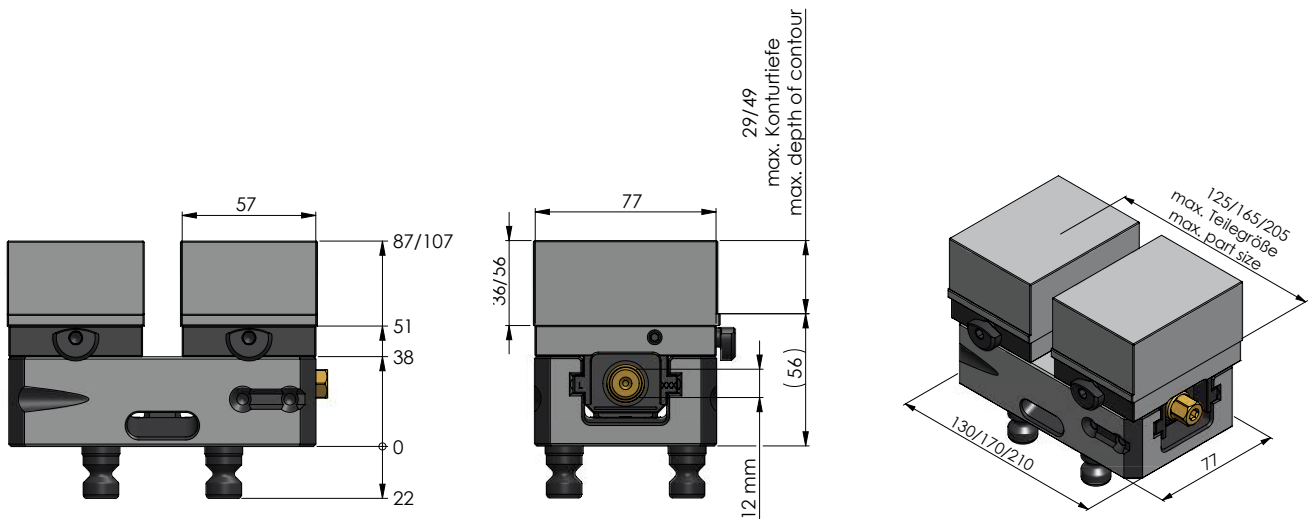



AVANTI 77 BASE JAWS, JAW WIDTH 77 MM

ITEM NO.	DIMENSIONS	WEIGHT	UNIT	COMPARABLE PREVIOUS VERSION
44771-77	77 × 57 mm	1.4 kg	1 pair	44771

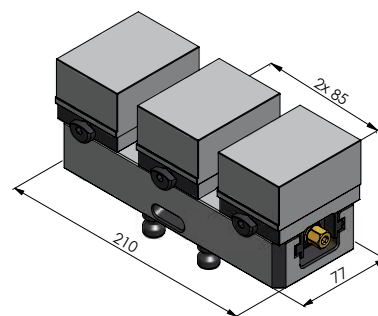
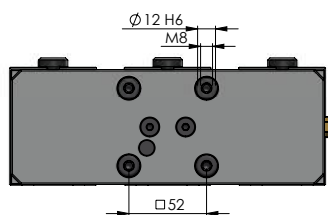
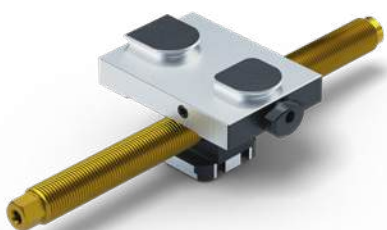

CENTER BASE JAW + SPINDLE FOR AVANTI 77, JAW WIDTH 77 MM

ITEM NO.	SPINDLE LENGTH (+ \varnothing)	FOR AVANTI	WEIGHT
44200-TG77	215 mm ($\varnothing 16$ mm)	44200-77	1.0 kg



AVANTI 77 TOP JAWS, SOFT

ITEM NO.	MATERIAL	DIMENSIONS	WEIGHT	UNIT
44778-36	Steel (16MnCr5)	78 × 58 × 36 mm	0.6 kg	1 pc.
44779-36	Aluminium (F50)	78 × 58 × 36 mm	0.2 kg	1 pc.
44778-56	Steel (16MnCr5)	78 × 58 × 56 mm	1.0 kg	1 pc.
44779-56	Aluminium (F50)	78 × 58 × 56 mm	0.3 kg	1 pc.

Top jaws fit the new base jaw version and also the previous one.

Avanti 125



AVANTI 125, JAW WIDTH 125 MM

ITEM NO.	BASE LENGTH	MAX. CLAMPING RANGE	WEIGHT	COMPARABLE PREVIOUS VERSION
44205-125*	210 mm	210 mm	11.2 kg	44205
44255-125	260 mm	260 mm	13.1 kg	44255
44305-125	310 mm	310 mm	15.0 kg	44305
44355-125	360 mm	360 mm	16.8 kg	44355

*automatable

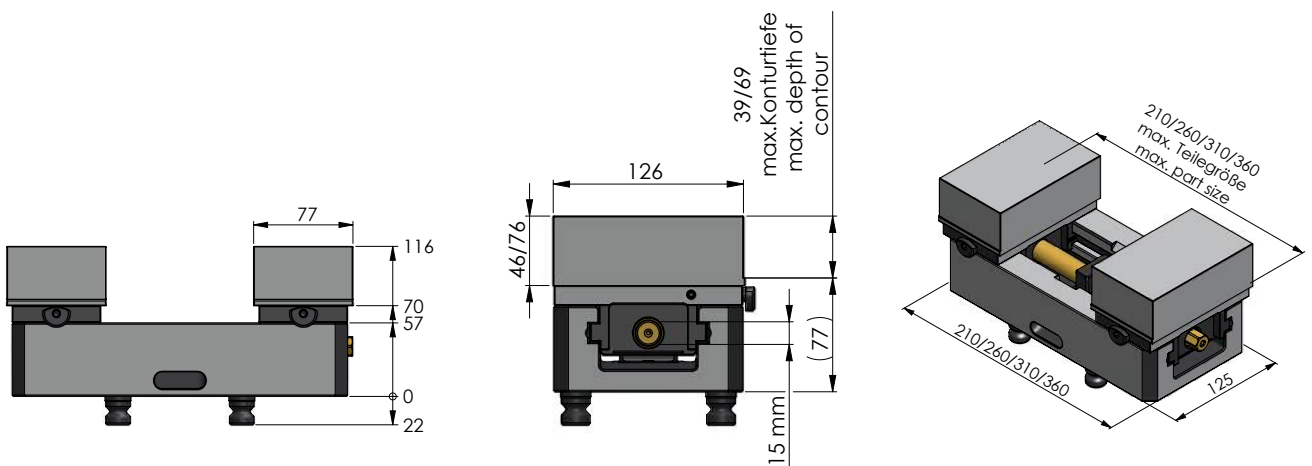



AVANTI 125 BASE JAWS, WIDTH 125 MM

ITEM NO.	DIMENSIONS	WEIGHT	UNIT	COMPARABLE PREVIOUS VERSION
44251-125	125 × 69 mm	3.6 kg	1 pair	44251

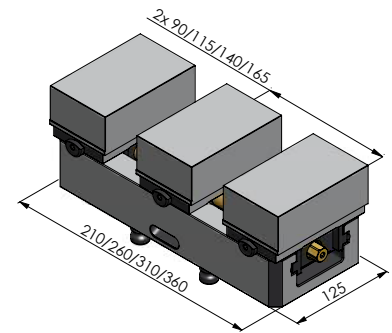
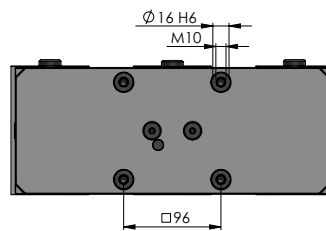
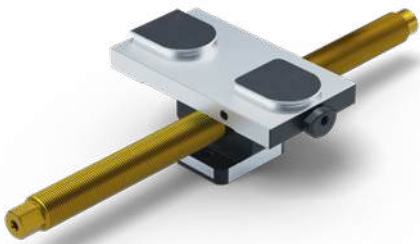

CENTER BASE JAW + SPINDLE FOR AVANTI 125

ITEM NO.	SPINDLE LENGTH (+Ø)	FOR AVANTI	WEIGHT
44255-TG125	264 mm (Ø 20 mm)	44255-125	1.9 kg
44305-TG125	314 mm (Ø 20 mm)	44305-125	2.0 kg
44355-TG125	364 mm (Ø 20 mm)	44355-125	2.1 kg



AVANTI 125 TOP JAWS, SOFT

ITEM NO.	MATERIAL	DIMENSIONS	WEIGHT	UNIT
44258-46	Steel (16MnCr5)	126 × 77 × 46 mm	3.3 kg	1 pc.
44259-46	Aluminium (F50)	126 × 77 × 46 mm	1.2 kg	1 pc.
44258-76	Steel (16MnCr5)	126 × 77 × 76 mm	5.5 kg	1 pc.
44259-76	Aluminium (F50)	126 × 77 × 76 mm	2.0 kg	1 pc.

Top jaws fit the new base jaw version and also the previous one.

Profilo Technology

The flexible clamping system for self-made top jaws or fixtures

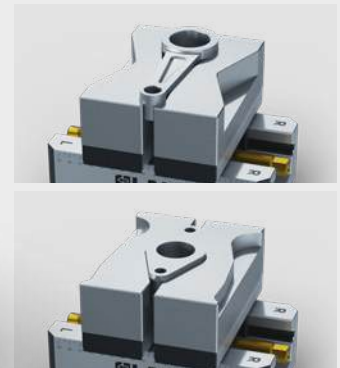
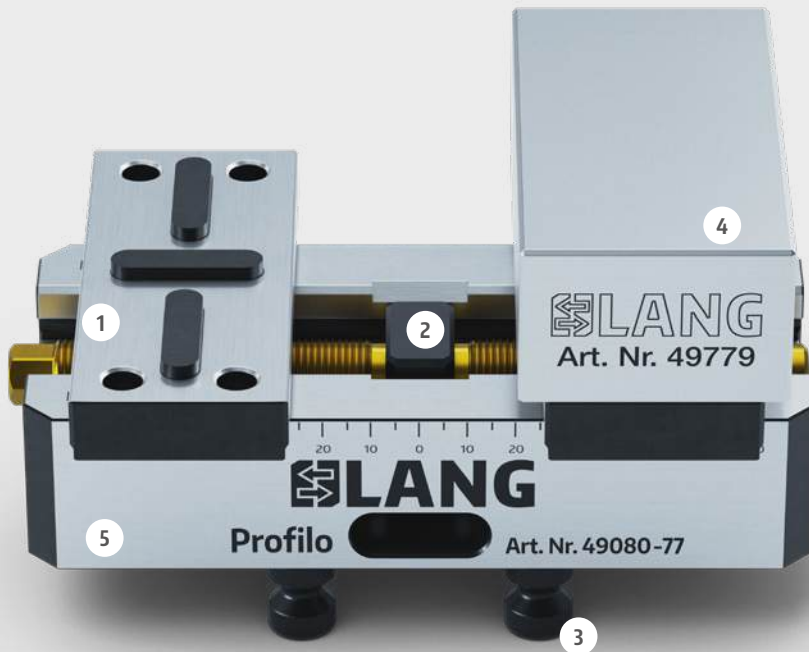

Large-volume steel or aluminium top jaw allows contours to be added on both sides of the jaws to use it for two different clamping applications.

- 1 Case-hardened, double guided base jaws with keyways
- 2 Centering accuracy ± 0.02 mm
- 3 Integrated with clamping studs for precise clamping in the Quick·Point® zero-point clamping system
- 4 Top jaws available in steel or aluminium
- 5 Rigid and sturdy base – but still lightweight and handy

Mounting options

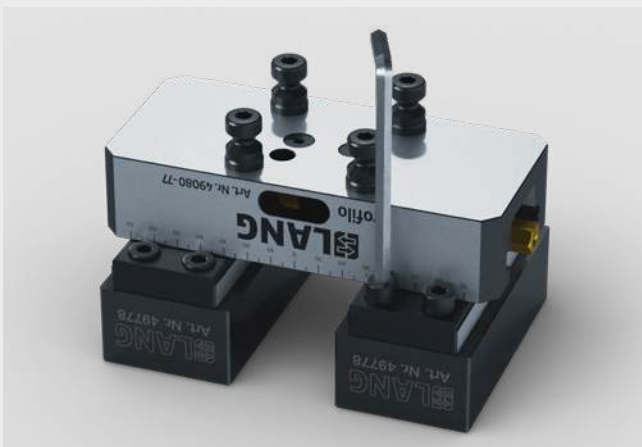

Soft jaws mounted from beneath with 4 screws.



Thanks to threads in the base jaws, top jaws can also be mounted from the top for better accessibility towards the screws.

Self-made Profilo top jaws

The versatile Profilo system allows you to manufacture your own, customized top jaws for your LANG vise. The drawings below show you how to machine your jaws. The drawings and 3D models can also be downloaded from our website.

Profilo 77:

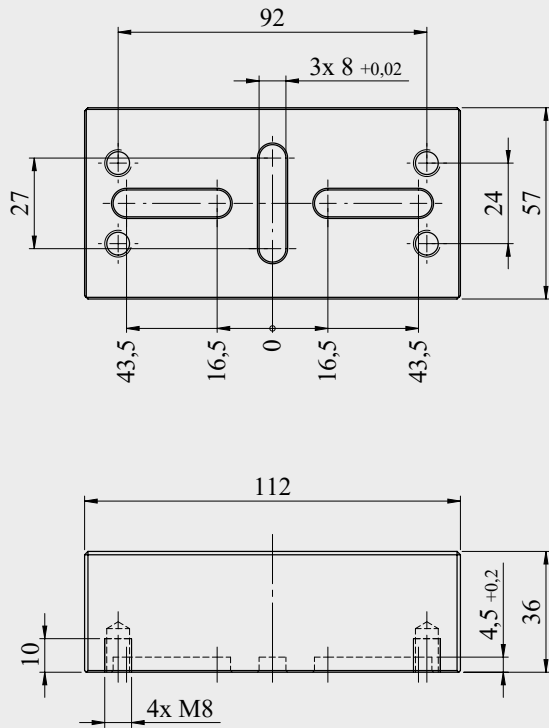

Profilo 125:

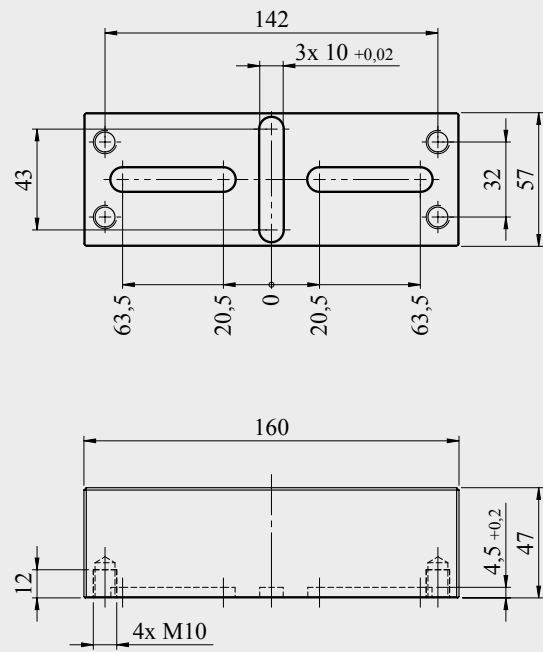

Applications

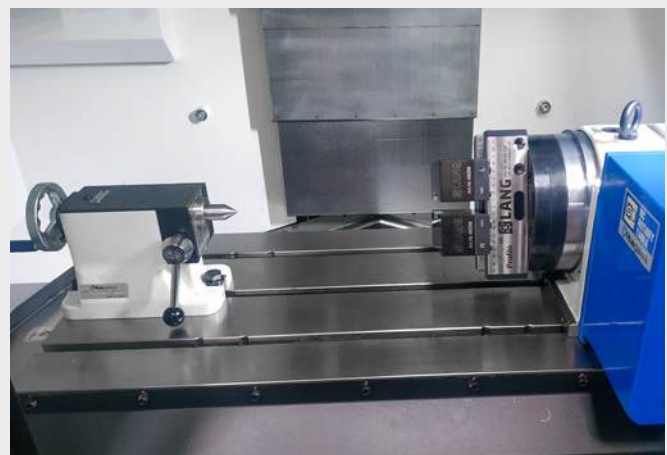
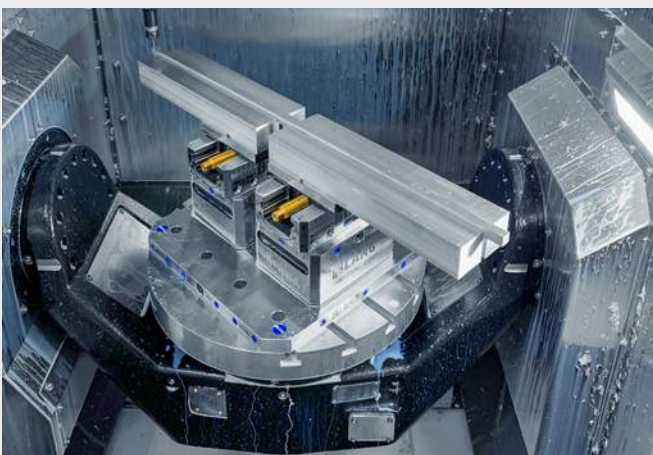
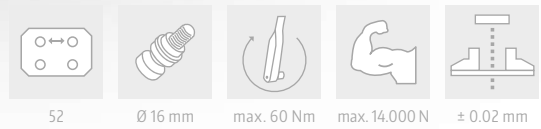

Image: CNC-Manufaktur Brüssow GmbH & Co. KG

Profilo 77



PROFILO 77

ITEM NO.	BASE LENGTH	MAX. CLAMPING RANGE	WEIGHT	COMPARABLE PREVIOUS VERSION
49010-77	102 mm	100 mm	3.2 kg	49010
49040-77	130 mm	130 mm	3.6 kg	49040
49080-77	170 mm	170 mm	4.3 kg	49080
49120-77	210 mm	210 mm	5.2 kg	49120

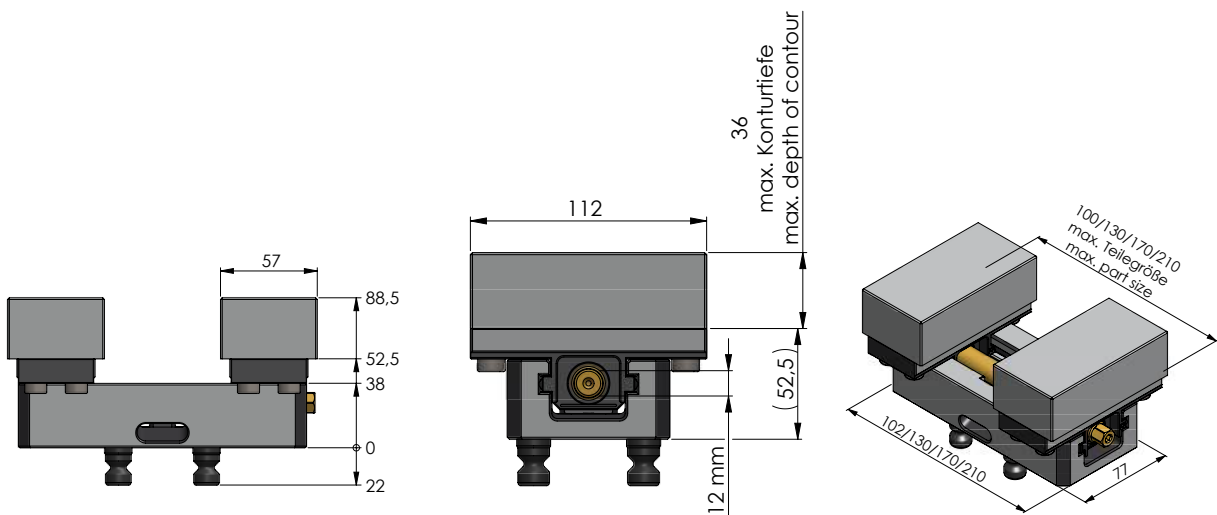



PROFILO 77 BASE JAWS

ITEM NO.	DIMENSIONS	WEIGHT	UNIT	COMPARABLE PREVIOUS VERSION
49077	112 × 46 mm	1.6 kg	1 pair	49771

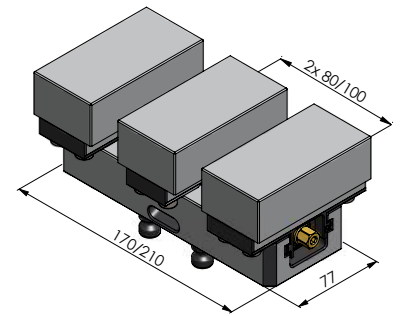
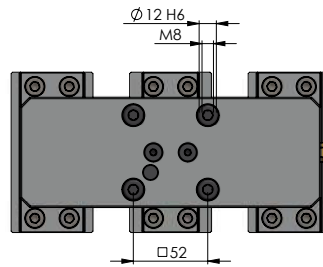

CENTER BASE JAW 112 × 46 MM + SPINDLE FOR PROFILO 77

ITEM NO.	SPINDLE LENGTH (+Ø)	FOR PROFILO	WEIGHT	COMPARABLE PREVIOUS VERSION
49080-TG77	175 mm (Ø 16 mm)	49080-77	1.0 kg	49080-TG
49120-TG77	215 mm (Ø 16 mm)	49120-77	1.1 kg	49120-TG



PROFILO 77 TOP JAWS, SOFT

ITEM NO.	MATERIAL	DIMENSIONS	WEIGHT	UNIT
49778	Steel (16MnCr5)	112 × 57 × 36 mm	1.8 kg	1 pc.
49779	Aluminium (F50)	112 × 57 × 36 mm	0.6 kg	1 pc.

Top jaws fit the new base jaw version and also the previous one.

Profilo 125



PROFILO 125

ITEM NO.	BASE LENGTH	MAX. CLAMPING RANGE	WEIGHT	COMPARABLE PREVIOUS VERSION
49050-125	160 mm	155 mm	10.0 kg	49050
49100-125	210 mm	205 mm	11.8 kg	49100
49150-125	260 mm	255 mm	13.6 kg	49150
49200-125	310 mm	305 mm	15.5 kg	49200
49250-125	360 mm	355 mm	17.3 kg	49250

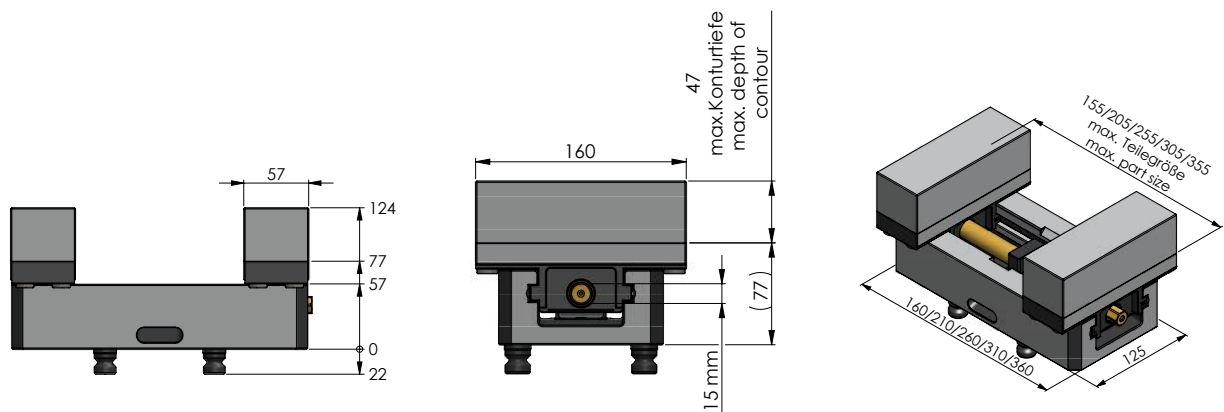



PROFILO 125 BASE JAWS

ITEM NO.	DIMENSIONS	WEIGHT	UNIT	COMPARABLE PREVIOUS VERSION
49125	160 × 57 mm	4.2 kg	1 pair	49251

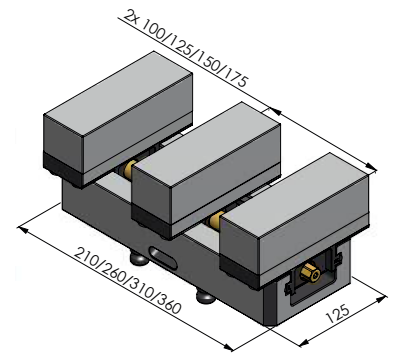
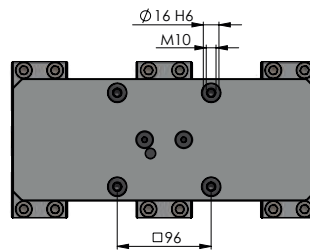

CENTER BASE JAW 160 × 57 MM + SPINDLE FOR PROFILO 125

ITEM NO.	SPINDLE LENGTH (+ \varnothing)	FOR PROFILO	WEIGHT	COMPARABLE PREVIOUS VERSION
49100-TG125	214 mm (\varnothing 20 mm)	49100-125	2.5 kg	49100-TG
49150-TG125	264 mm (\varnothing 20 mm)	49150-125	2.6 kg	49150-TG
49200-TG125	314 mm (\varnothing 20 mm)	49200-125	2.7 kg	49200-TG
49250-TG125	364 mm (\varnothing 20 mm)	49250-125	2.9 kg	49250-TG

PROFILO 125 TOP JAWS, SOFT



ITEM NO.	MATERIAL	DIMENSIONS	WEIGHT	UNIT
49258	Steel (16MnCr5)	160 × 57 × 47 mm	3.3 kg	1 pc.
49259	Aluminium (F50)	160 × 57 × 47 mm	1.2 kg	1 pc.

Top jaws fit the new base jaw version and also the previous one.

Vario-Tec Technology

The convenient and versatile clamping solution for (semi-) finished parts.

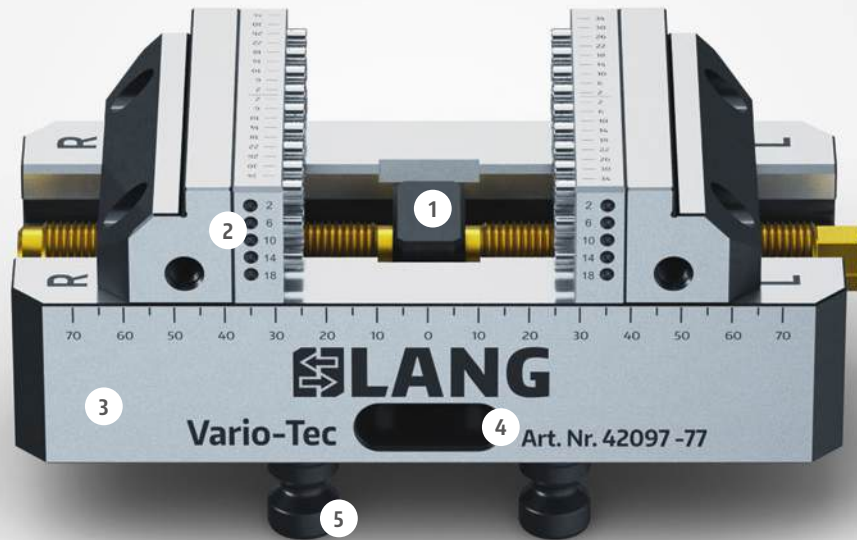

- 1 Centering accuracy ± 0.02 mm
- 2 Channels for blowing out pins
- 3 Rigid and sturdy base for great longevity
- 4 Lateral swarf/coolant drain in the base body
- 5 Integrated with clamping studs for precise clamping in the Quick-Point® zero-point clamping system

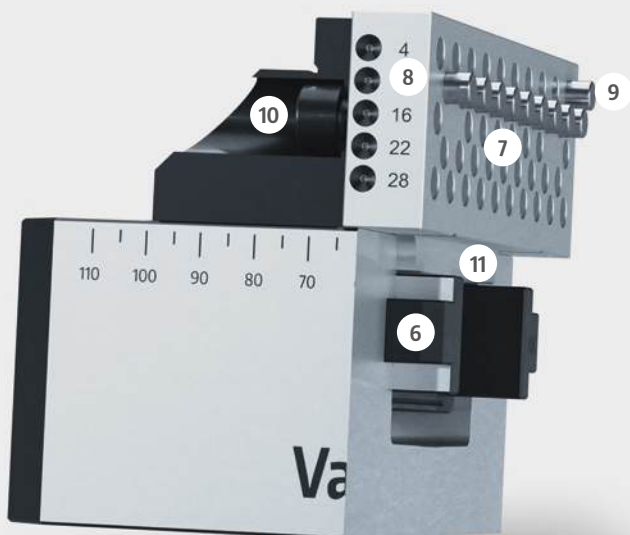

- 6 Double guided jaws
- 7 Positioning accuracy of pins ± 0.01 mm
- 8 Pins are blown out row by row with compressed air
- 9 Support and resting possibilities. Parallels are not needed
- 10 Jaws are sealed up front and mounted from behind through the carrier jaw. No swarf clogging possible!
- 11 Pin jaws are guided in the base for a highly accurate location to one another

Applications



Pins not needed are simply pushed back by hand. The remaining pins act as a support and resting system.



Parallels and additional endstops which affect accessibility in a negative way are not needed.



Resting a workpiece on only two pins ensures great freedom to machine until close to the edge of the workpiece and inner surfaces of the clamping pin jaws.

Maintenance recommendation



In order to keep up the proper function of the system the pins should be blown out when not needed to prevent jamming caused by the coolant. Furthermore we recommend applying a multi-purpose oil on the pins occasionally.

Vario-Tec 77

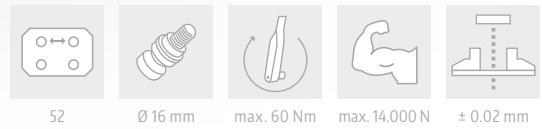

VARIO-TEC 77

ITEM NO.	BASE LENGTH	MAX. CLAMPING RANGE	WEIGHT	COMPARABLE PREVIOUS VERSION
42057-77*	130 mm	57 mm	3.3 kg	42057
42097-77	170 mm	97 mm	4.0 kg	42097
42137-77	210 mm	137 mm	4.6 kg	42137

*automatable

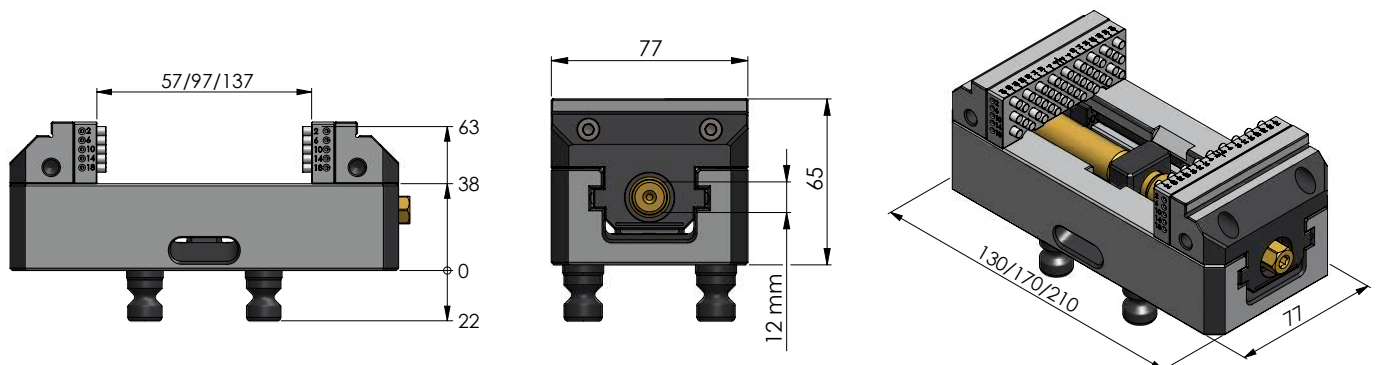

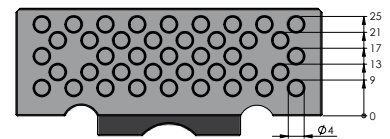
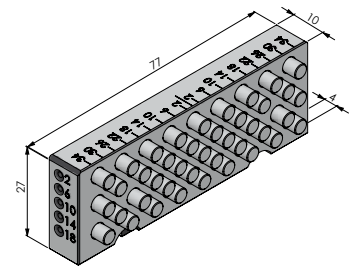

The jaws are fixed with screws from behind (2 × M6, distance of 48 mm), so they are sealed up front. Hence swarf clogging has no chance!

VARIO-TEC 77 SPARE JAWS

ITEM NO.	DESCRIPTION	UNIT	WEIGHT	COMPARABLE PREVIOUS VERSION
42018-77	Spare Jaws	1 set (2 pin jaws + 2 carrier jaws)	1.2 kg	42077

ACCESSORIES VARIO-TEC 77



ITEM NO.	DESCRIPTION	UNIT
20000	Spare pins Ø 4 mm	5 pcs.
200009	O-Rings Ø 2 × 1.5 mm for spare pins Ø 4 mm	100 pcs.
20004	Compressed Air Gun	1 pc.

Vario-Tec 125

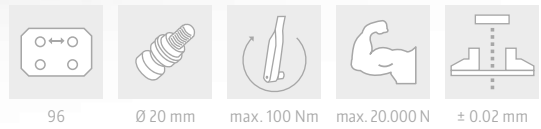

VARIO-TEC 125

ITEM NO.	BASE LENGTH	MAX. CLAMPING RANGE	WEIGHT	COMPARABLE PREVIOUS VERSION
42102-125*	210 mm	100 mm	12.3 kg	42102
42152-125	260 mm	150 mm	14.3 kg	42152
42202-125	310 mm	200 mm	16.0 kg	42202
42252-125	360 mm	250 mm	17.7 kg	42252

*automatable

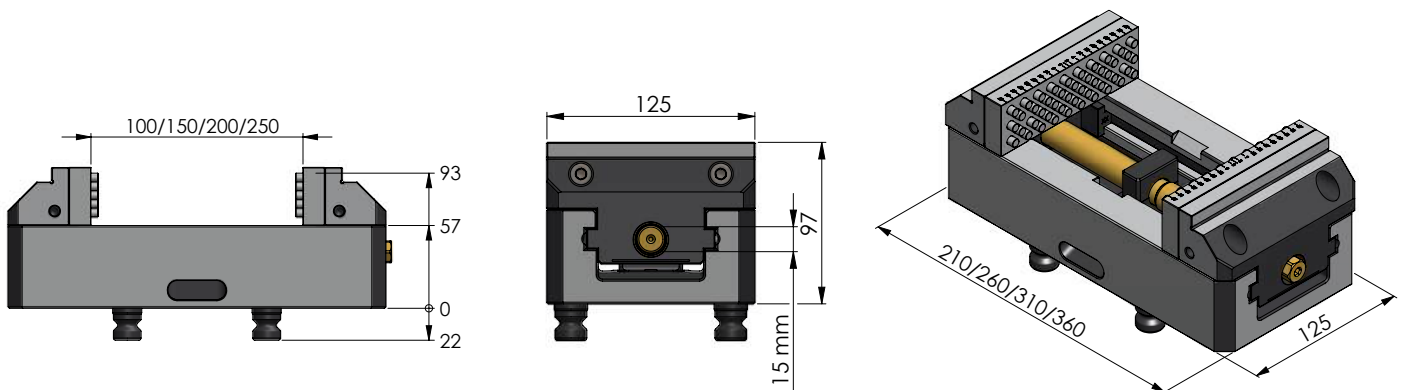

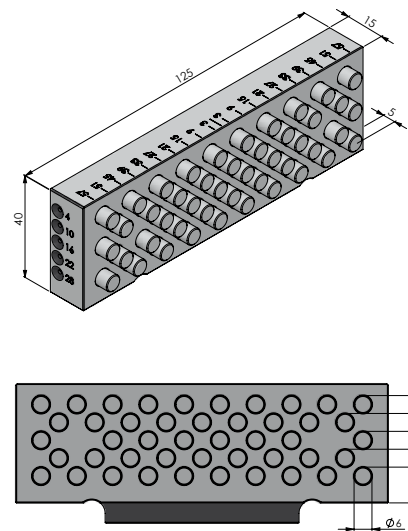

The jaws are fixed with screws from behind (2 × M 8, distance of 84 mm), so they are sealed up front. Hence swarf clogging has no chance!

VARIO-TEC 125 SPARE JAWS

ITEM NO.	DESCRIPTION	UNIT	WEIGHT	COMPARABLE PREVIOUS VERSION
42018-125	Spare Jaws	1 set (2 pin jaws + 2 carrier jaws)	4.6 kg	42125

ACCESSORIES VARIO-TEC 125



ITEM NO.	DESCRIPTION	UNIT
20001	Spare pins Ø 6 mm	5 pcs.
200010	O-Rings Ø 3.5 × 2 mm for spare pins Ø 6 mm	100 pcs.
20004	Compressed Air Gun	1 pc.

Preci-Point Collet Chuck

The collet chuck with ideal accessibility for milling round parts



- 1 Suitable for commercially available collets type ER 32 (clamping range \varnothing 3 – 20 mm) and ER 50 (clamping range \varnothing 6 – 34 mm)
- 2 M6 tapped hole to use an endstop
- 3 Robust, case-hardened and coated base body
- 4 Equipped with clamping studs for precise clamping in the Quick-Point® zero-point clamping system
- 5 Recess as a coolant drainage

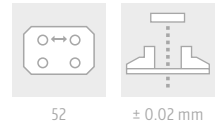
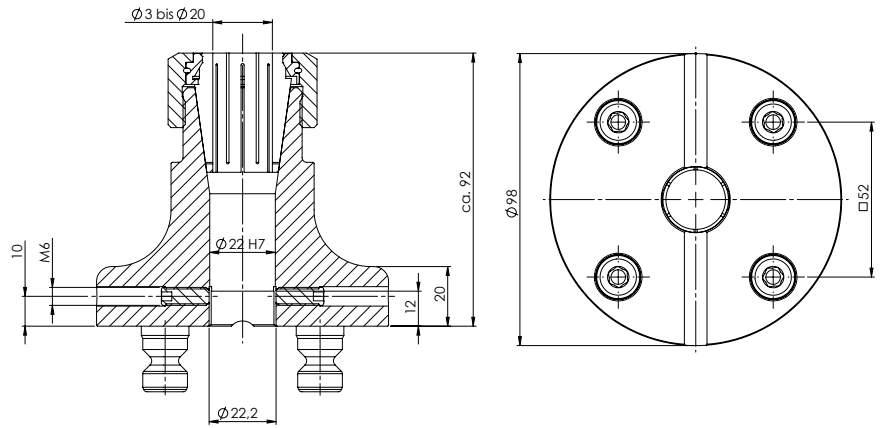

PRECI-POINT COLLET CHUCK FOR ER 32

ITEM NO.	DIMENSIONS	CLAMPING RANGE	WEIGHT
41032	Ø 98 × 92 mm	Ø 3 - 20 mm	2.0 kg

Included: 4 × Quick-Point® clamping studs Ø 16 mm and screwcap.

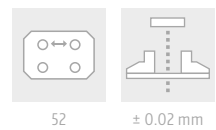
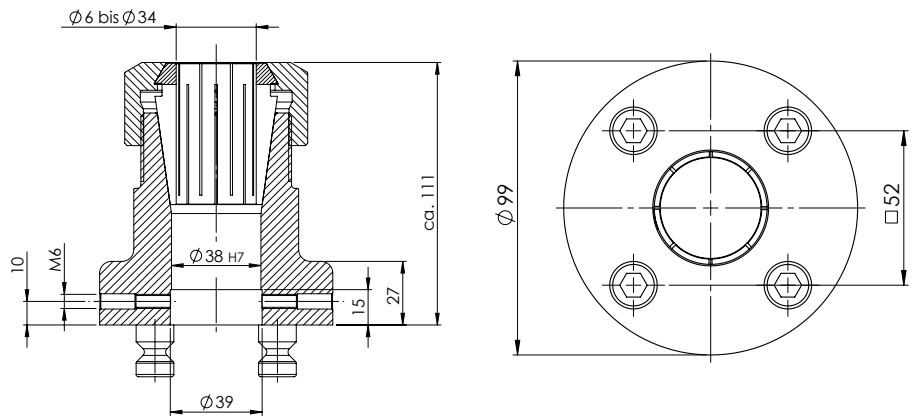

PRECI-POINT COLLET CHUCK FOR ER 50

ITEM NO.	DIMENSIONS	CLAMPING RANGE	WEIGHT
41052	Ø 99 × 111 mm	Ø 6 - 34 mm	2.9 kg

Included: 4 × Quick-Point® clamping studs Ø 16 mm and screwcap.



PRECI-POINT CLAMPING WRENCH

ITEM NO.	FOR PRECI-POINT
41032-03	ER 32
41052-03	ER 50

Spare Parts for former vise versions

On this double page you find all spare parts for older vises (versions until September 2018)

5-AXIS VISE



SPARE JAWS

Makro-Grip® 46	47046-20	Spare Jaws Makro-Grip® 46
Makro-Grip® 77	47077-20	Spare Jaws Makro-Grip® 77
	47085-20	Spare Jaws Makro-Grip® 77, for Item No. 47085
Makro-Grip® 125	47125-20	Spare Jaws Makro-Grip® 125

AVANTI



BASE JAWS

44461	Avanti Base Jaws 46
44771	Avanti Base Jaws 77
44251	Avanti Base Jaws 125

PROFILO



BASE JAWS

49771	Profilo Base Jaws 77
49251	Profilo Base Jaws 125

CENTER BASE JAWS + SPINDLES



49080-TG	Center Base Jaw 77 + Spindle Ø 16 mm, length 175 mm
49120-TG	Center Base Jaw 77 + Spindle Ø 16 mm, length 215 mm
49100-TG	Center Base Jaw 125 + Spindle Ø 20 mm, length 215 mm
49150-TG	Center Base Jaw 125 + Spindle Ø 20 mm, length 265 mm
49200-TG	Center Base Jaw 125 + Spindle Ø 20 mm, length 315 mm
49250-TG	Center Base Jaw 125 + Spindle Ø 20 mm, length 365 mm

VARIO-TEC



SPARE JAW SETS

42077	Spare Jaw Set 77 (2 pin jaws + 2 carrier jaws)
42125	Spare Jaw Set 125 (2 pin jaws + 2 carrier jaws)

5-AXIS VISE



CENTER PIECES + SPINDLES

Makro-Grip® 46	4046082	Center Piece + Spindle Ø 12 mm, length 82 mm
	4046122	Center Piece + Spindle Ø 12 mm, length 122 mm
	4046162	Center Piece + Spindle Ø 12 mm, length 162 mm
Makro-Grip® 77	4077102	Center Piece + Spindle Ø 16 mm, length 102.5 mm
	4077135	Center Piece + Spindle Ø 16 mm, length 135 mm
	4077175	Center Piece + Spindle Ø 16 mm, length 175 mm
	4077215	Center Piece + Spindle Ø 16 mm, length 215 mm
Makro-Grip® 125	4025165	Center Piece + Spindle Ø 20 mm, length 165 mm
	4025215	Center Piece + Spindle Ø 20 mm, length 215 mm
	4025265	Center Piece + Spindle Ø 20 mm, length 265 mm
	4025315	Center Piece + Spindle Ø 20 mm, length 315 mm
	4025365	Center Piece + Spindle Ø 20 mm, length 365 mm



CENTER JAWS + SPINDLES FOR DUAL CLAMPING

Makro-Grip® 46	47065-TG	Center Jaw + Spindle Ø 12 mm, length 82 mm
	47105-TG	Center Jaw + Spindle Ø 12 mm, length 122 mm
	47145-TG	Center Jaw + Spindle Ø 12 mm, length 162 mm
Makro-Grip® 77	47085-TG17	Center Jaw 17 mm + Spindle Ø 16 mm, length 102.5 mm
	47085-TG27	Center Jaw 27 mm + Spindle Ø 16 mm, length 102.5 mm
	47120-TG17	Center Jaw 17 mm + Spindle Ø 16 mm, length 135 mm
	47120-TG27	Center Jaw 27 mm + Spindle Ø 16 mm, length 135 mm
	47160-TG17	Center Jaw 17 mm + Spindle Ø 16 mm, length 175 mm
	47160-TG27	Center Jaw 27 mm + Spindle Ø 16 mm, length 175 mm
	47200-TG17	Center Jaw 17 mm + Spindle Ø 16 mm, length 215 mm
	47200-TG27	Center Jaw 27 mm + Spindle Ø 16 mm, length 215 mm
Makro-Grip® 125	47155-TG17	Center Jaw 17 mm + Spindle Ø 20 mm, length 165 mm
	47155-TG27	Center Jaw 27 mm + Spindle Ø 20 mm, length 165 mm
	47205-TG17	Center Jaw 17 mm + Spindle Ø 20 mm, length 215 mm
	47205-TG27	Center Jaw 27 mm + Spindle Ø 20 mm, length 215 mm
	47255-TG17	Center Jaw 17 mm + Spindle Ø 20 mm, length 265 mm
	47255-TG27	Center Jaw 27 mm + Spindle Ø 20 mm, length 265 mm
	47305-TG17	Center Jaw 17 mm + Spindle Ø 20 mm, length 315 mm
	47305-TG27	Center Jaw 27 mm + Spindle Ø 20 mm, length 315 mm
	47355-TG17	Center Jaw 17 mm + Spindle Ø 20 mm, length 365 mm
	47355-TG27	Center Jaw 27 mm + Spindle Ø 20 mm, length 365 mm

SPINDLE COVERS

Makro-Grip® 46	47046-80	Spindle Covers Foam, 10 pcs.
Makro-Grip® 77	47077-70	Spindle Covers Plastic, 10 pcs.
	47077-80	Spindle Covers Foam, 10 pcs.
Makro-Grip® 125	47125-70	Spindle Covers Plastic, 10 pcs.
	47125-80	Spindle Covers Foam, 10 pcs.

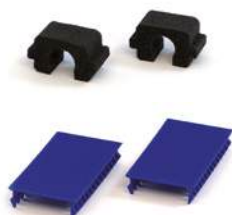

Terms & Conditions

Offer validity

Our offers are valid for 45 days and may be revoked by us at any time thereafter.

Prices

Prices are ex works, excluding packaging, transport, customs and plus the statutory value added tax. This shall also apply in the case of agreed partial deliveries and express deliveries.

Minimum order value

The minimum order value is € 30.00 net. In the case of a lower order value, the minimum amount of € 30.00 plus statutory value added tax will be charged.

Reservation of ownership

The delivered goods remain our property until full payment of the purchase price and can be reclaimed at any time, in which case the costs for this will be invoiced.

Incorrect order / return

Returns are possible up to a maximum of four weeks after receipt of the goods. The returned goods must not show any signs of use. If goods are returned with visual damage, restocking costs amounting to 20% of the value of the goods will be charged.

You can find the complete Terms & Conditions on our website www.lang-technik.de.

Imprint

Title:

LANG Workholding - Spring 2022

Date of Printing 3/2022

Editor:

LANG Technik GmbH

Albstraße 1-6

D-73271 Holzmaden

Phone: +49 7023 9585-0

Fax: +49 7023 9585-100

www.lang-technik.de

info@lang-technik.de

Legal provisions:

Copyright © 2022

LANG Technik GmbH

All rights reserved. Reprint, recording in online-services, internet and duplication on data carrier as CD ROM, DVD, etc. or in extracts are prohibited. Misprints, errors and changes are subject to modifications. All indications of weight are approximate values. Illustrations can vary from articles.

Symbols

To simplify specifications we use these symbols to highlight technical information and the compatibility of the products:



Grid system:

Zero-point pitch



Clamping stud size:

Diameter of the clamping studs



Quick-Lock:

The fastener can be attached



Vise size:

Width of vise



Torque:

Maximum allowed torque



Clamping force:

Clamping force at maximum torque



Centering accuracy:

Centering tolerance of vises



Mounting bores:

Individual mounting bores and keyways are possible



Automatable:

Automation interface included



→ facebook.com/langtechnik
→ instagram.com/langtechnik

→ twitter.com/langtechnik
→ youtube.com/langtechnik

→ linkedin.com/company/lang-technik
→ www.lang-technik.de