

BROOKFIELD POWDER FLOW TESTER

Operating Instructions Manual

No. **M09-1200-F1016**

Revision 2.0



Instrumentation & Specialty Controls Division

11 Commerce Boulevard, Middleboro, MA 02842 USA
Tel: 608-946-6200 or 800-628-8139 (USA excluding MA)
Fax: 608-946-6262 Internet: <http://www.brookfieldengineering.com>

Table of Contents

I. INTRODUCTION.....	5
I.1 Components	6
I.2 Utilities.....	7
I.3 Specifications	7
I.4 Dimensions	9
I.5 Safety Symbols and Precautions.....	10
I.6 Back Panel	11
I.7 Key Functions	12
I.8 Test Stop - Reset	12
I.9 Installation.....	13
I.10 Cleaning.....	14
II. QUICK START PROCEDURE.....	15
III. SAMPLE PREPARATION AND HANDLING	19
III.1 Sample Issues	19
III.2 Sample Trough	20
III.3 Lid Selection	21
III.4 Outer Catch Tray	22
III.5 Inner Catch Tray with Shaping Blade	22
III.6 Loading the Trough with Sample.....	23
III.7 Placement of the Trough and Lid on the Instrument.....	23
III.8 Removal of Trough and Lid from Instrument.....	24
III.9 Clean-up.....	24
IV. POWDER FLOW PRO SOFTWARE.....	25
IV.1 Main Screen and Setup Tab.....	25
IV.2 Sample Information.....	26
IV.3 Standard Test Method.....	27
IV.4 Custom Test Method	28
IV.5 Test Execution.....	29
IV.6 How to Stop the Test	34
IV.7 Analysis Section.....	35
IV.7.1 How to Save Data.....	35
IV.7.2 Choices for Data Display	35
IV.7.3 How to Create a Data Report	44
IV.7.4 How to Compare Data.....	45
IV.8 Statistics Page.....	47
IV.9 Custom Page.....	49
IV.10 Importing and Exporting Data	50
IV.11 Help Files	50
Appendix A: Overview of Powder Flow Properties	53
Appendix B: Glossary	61
Appendix C: PFT Packing to Ship for Repair and Service.....	64
Appendix D: Warranty Repair and Service	74

I. INTRODUCTION

There is a need throughout industry to characterize powder flow properties and flow behavior. The Brookfield Powder Flow Tester (PFT) is a precision instrument of robust design that satisfies this need and can be used to measure, display and print out flow results at specified compaction loads. Potential users include R&D Departments, QC laboratories, Incoming Inspection for raw materials, and government/university organizations.

The principal of operation of the PFT is to drive a compression lid vertically downward into a powder sample contained in an annular shear cell. The powder sample has a defined volume and the weight of the sample is measured before the start of the test. A calibrated beam load cell is used to control the compaction stress applied to the powder. The annular shear cell is then rotated at a defined speed and the torque resistance of the powder in the shear cell moving against the powder in the stationary lid is measured by a calibrated reaction torque sensor. The geometries of the lid, shear cell, rotational speed of the cell, and the compressive loads applied to the powder all contribute to the calculations which determine the “flowability” of the powder.

The intended uses for the PFT include:

- Pass/fail tests to certify material quality prior to shipment
- Providing meaningful numbers that guide how powder will flow in silos, hoppers, feeders, filling machines and similar equipment
- Benchmarking for daily production lots or for comparing flow behavior of new formulations against existing product
- Creating databases for choice of production lines, sourcing, formulation and second source suppliers
- Producing quantitative results that can be used for design of processing plants and equipment

There are several powder flow properties which the PFT measures to categorize flowability. Note that these properties, which may vary with changes in temperature and humidity, include:

- Unconfined failure strength
- Major Principal Consolidating Stress
- Time Consolidation
- Angle of internal friction
- Angle of wall friction
- Cohesive strength
- Bulk density

The most recognized indication of powder flowability is the unconfined failure strength when viewed as a function of the consolidating stress, known as the flow function. Wall friction, internal friction, and bulk density are also commonly used to relate measurements to flow behavior. Appendix A provides a more detailed explanation of these properties and how they are measured.

I.1 Components

<u>DESCRIPTION</u>	<u>PART NUMBER</u>
<u>Powder Flow Tester</u>	
Powder Flow Tester 115VAC <i>or</i>	PFT3115
Powder Flow Tester 230VAC	PFT3230
Power Cord 115 Volt <i>or</i>	DVP-65
Power Cord 230 Volt	DVP-66
<u>Optional Items</u>	
Standard Accessory Kit	PFT-610
Includes the following items:	
• Sample Trough Aluminum (230 cc, 6-in. dia.)	PFT-400
• Vane Lid 304 S/S (34 cc, 6-in. dia.)	PFT-500
• Wall Lid 304 S/S, 2B finish (6-in. dia.)	PFT-507
• Catch Trays & Shaping Blade	PFT-600
• Powder Scoop	PFT-611
• Cleaning Brush	PFT-612
• 3/8" Wrench [for leveling the instrument]	CP-23
• Shipping Foam	PFT-101
• Operator Manual	M09-1200
<u>Optional Items for Standard Accessory Kit</u>	
Wall Lid, Tivar 88, 6-in. dia.	PFT-512
Wall Lid, Mild Steel, 6-in. dia.	PFT-513
Portable Carrying Case	RK-PFTCKIT
<u>Optional Small Volume Shear Cell Kit</u>	
Includes the following items:	PFT-620
• Small Trough (38 cc, 5-in. dia.)	PFT-405
• Small Vane Lid, 304 S/S (5 cc, 5-in. dia.)	PFT-515
• Small Wall Lid, 304 S/S, 2B Finish (5-in. dia.)	PFT-516
• Catch Trays & Shaping Blade	PFT-618
• Powder Scoop	PFT-611
• Cleaning Brush	PFT-612
• Wrench [for leveling the instrument]	CP-23
• Shipping Foam	PFT-106
<u>Optional Accessory Items for Small Volume Kit</u>	
Wall Lid, Tivar 88, 5-in. dia.	PFT-520
Wall Lid, Mild Steel, 5-in. dia.	PFT-522
<u>Optional Accessory items</u> that can be ordered for use with the Powder Flow Tester include the following:	
Humidity Sensor with interface cable	PFT-607Y
RTD Temperature Sensor with interface cable	DVP-94Y
Sample Trough Aluminum (230 cc, 6-in. dia.)	PFT-400
Sample Trough Aluminum (230 cc, 5-in. dia.)	PFT-405

Perforated Screen (230 cc, 6-in. dia.)	PFT-440
Perforated Screen (230 cc, 5-in. dia.)	PFT-442
Inner Catch Tray with Shaping Blade (230 cc, 6-in. dia.)	PFT-6Y
Inner Catch Tray with Shaping Blade (230 cc, 5-in. dia.)	PFT-5Y
Outer Catch Tray (230 cc, 6-in. dia.)	PFT-8
Outer Catch Tray (230 cc, 5-in. dia.)	PFT-7

Sieve Kits

PFT Sieve Kit for Standard Cell	PFT-626
• Adapter, 6-in.	PFT-622
• Sieve, 850 micro-meters	PFT-623
• Cone	PFT-621
• Brush, 7/8 rd. all metal, 302 S/S	PFT-628
PFT Sieve Kit for Small Cell	PFT-627
• Adapter, 5-in.	PFT-624
• Sieve, 425 micro-meters	PFT-625
• Cone	PFT-621
• Brush, 7/8 rd. all metal, 302 S/S	PFT-628

I.2 Utilities

Input Voltage:	90-265 VAC
Input Frequency:	47-63 HZ
Power consumption:	150VAC
Fuse:	Two 2 AMP, 5 x 20mm, FAST-ACTING

Power Cord Color Code:	<u>United States</u>	<u>Outside United States</u>
Hot (live)	Black	Brown
Neutral	White	Blue
Ground (earth)	Green	Green/Yellow

I.3 Specifications

Load for vertical axis compression:	7 kg	Accuracy: +/-0.6% of full scale range
Torque:	+/- 7.0 N•m	Accuracy: +/-1.2% of full scale range
Distance:	Accuracy +/- 0.3 mm	
Torsional speed:	1 revolution per hour (RPH) up to 5 RPH with 0.1RPH increments. Default setting 1RPH When using Keypad: 10 RPH	
Axial speeds:	0.1 mm/sec up to 5 mm/sec with 0.1 mm/sec increments. Default setting 1 mm/sec When using Keypad: 5 mm/sec	

Temperature:	Requires optional temperature probe (Part No. DVP-94Y). -20°C to 120°C. Accuracy +/- 1.0°C.
Humidity Sensing:	Requires optional humidity sensor (Part No. PFT-607Y). 10% to 95% RH Accuracy +/-3% (35-75% RH), +/-5% (<35% RH, >75% RH)
Output:	USB Port or RS-232 compatible Serial Port
Particle Size:	The maximum particle size for the Standard Volume Shear Cell is 1 mm, assuming a relatively monosized material. A small size fraction at 2 mm with 90% below 1 mm is acceptable. For the Small Volume Shear Cell, the maximum particle size is 250 micron, assuming a monosized material. A small size fraction at 500 micron with 90% below 250 micron is acceptable.
Environmental Conditions:	0°C to 40°C temperature range (32°F to 104°F) 20%-80% relative humidity, non condensing atmosphere
Use:	Intended for indoor use only. Altitude up to 2000 meters
Dimensions:	36.2 cm (14 1/4") W x 39.7 cm (15 5/8") D x 67.6 cm (26 5/8") H (See Figure I-1)
Weight:	34 kg (75 lb)

Minimum System Requirements for the Powder Flow Pro software:

Microprocessor:	2GHz processor
Memory:	512 MB of RAM
Hard Drive Space:	30 MB available
Video:	1024 x 768 resolution, 128 MB of graphics memory
Operating System:	Windows XP or above
Communications Port:	One USB or RS-232 port

I.4 Dimensions

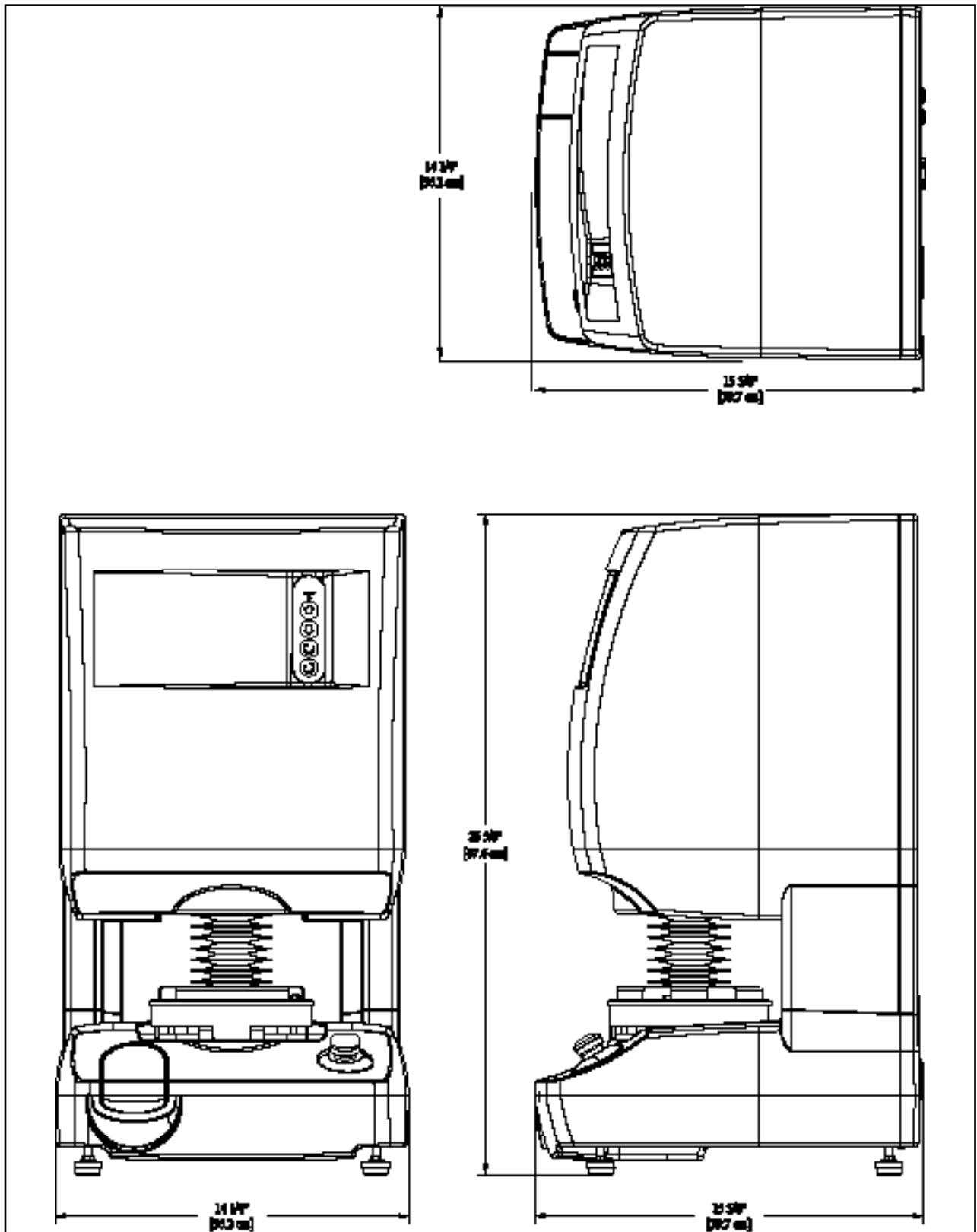

Figure I-1: PFT Dimensions

I.5 Safety Symbols and Precautions

Safety Symbols



Refer to the manual for specific warning or caution information to avoid personal injury or damage to the instrument.



Keep hands, fingers and other body parts clear of moving parts when operating instrument.



Functional Earth Terminal Main power entry module must have an earth conductor, to ensure against electronic failure.

Precautions



If this instrument is used in a manner not specified by the manufacturer, the protection provided by the instrument may be impaired.



This instrument is not intended for use in a potentially hazardous environment.



In case of emergency, turn off the instrument and then disconnect the electrical cord from the wall outlet.



The user should ensure that the substances placed under test do not release poisonous, toxic, or flammable gases at the temperature which they are subjected to during the test.



The torque reaction sensor will be damaged if more than 150% of the FSR torque (+/- 7.0 N•m) is applied.

I.6 Back Panel

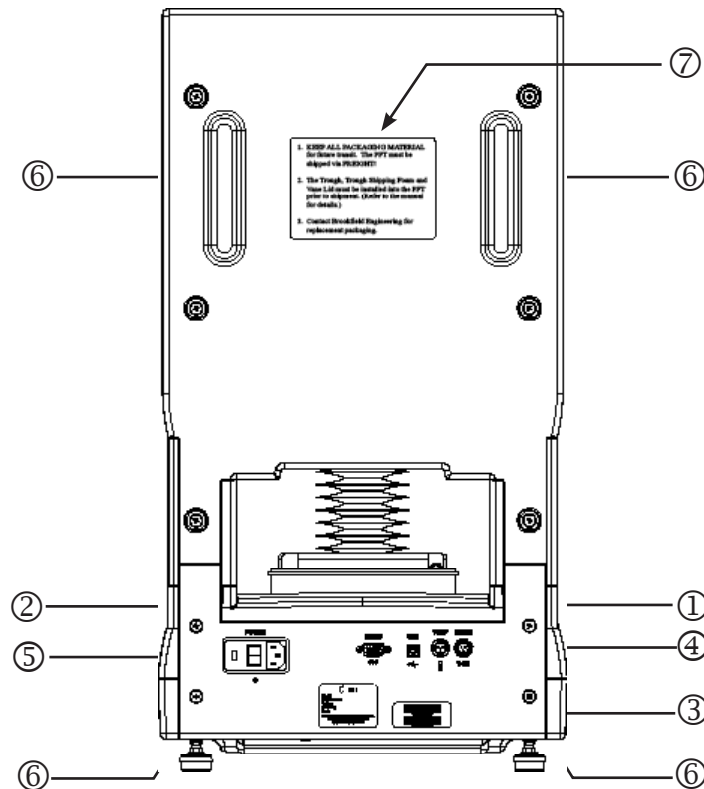



Figure I-2: Back Panel

1. USB Type B port
Use with USB Cable P/N DVP-202 to connect instrument to a computer. Cable USB 2.0 A Male to B Male.
2. RS-232 Serial Port
Use with RS-232 Cable P/N DVP-80 to connect instrument to a computer.
3. Temperature Probe Plug
4-Pin plug. Use with Temperature Probe P/N DVP-94Y.
4. Humidity Sensor Plug
3-Pin plug. Use with P/N PFT-607Y.
5. Power entry module:
ON/OFF switch-fused (see Utilities section) Voltage 90-265 VAC.
6.  Hand Hold locations for handling instrument. Recommend two people for movement of instrument due to heavy weight.
7. Label with the instructions for shipment of unit by freight carrier.

I.7 Key Functions

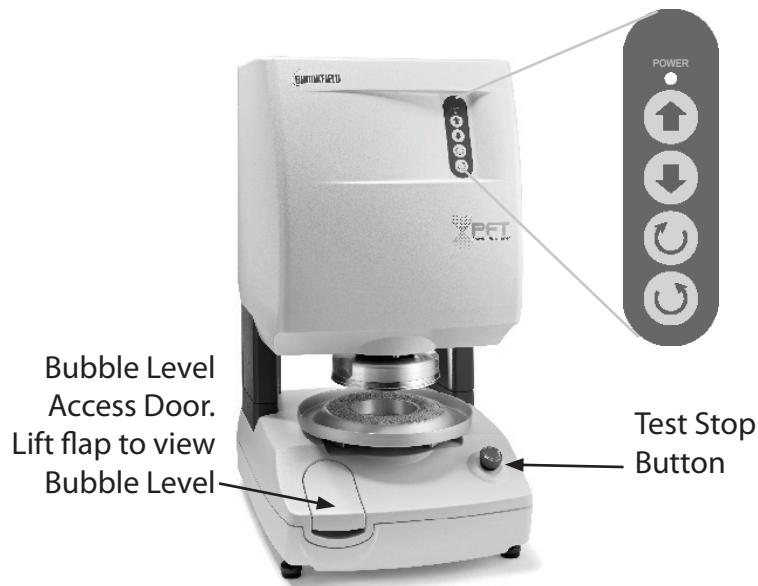

Figure I-3: Control keys for standalone mode

The control keys are used only for manual positioning of the compression lid assembly and the sample trough drive. Powder Flow Pro™ Software is required for all other operations.

Keypad

- ↑ This key is used to move the compression plate assembly UP away from the sample trough drive assembly. It is also commonly used for general purposes.
- ↓ This key is used to move the compression plate assembly DOWN towards the sample trough drive assembly.
- ↻ This key is used to rotate the sample trough drive assembly clockwise.
Note: This key is also used during calibration.
- ↻ This key is used to rotate the sample trough drive assembly counter-clockwise.
Note: This key is also used during calibration.

I.8 Test Stop - Reset

This button is used in case of an emergency situation. When this button is depressed, all software control is blocked and movement halts. Note that the manual control buttons on the instrument can still be used to reposition the lid and trough as necessary. Once the emergency situation is cleared, this button must be rotated to reset. After using the Test Stop button, both the instrument and the software should be restarted to ensure that normal communications have been reestablished.

I.9 Installation

Please follow the instructions listed below to unpack the PFT. This instrument is a sensitive load measuring device. It should be installed on a clean, solid, level bench surface which is free from external vibrations.

1. Unpack the Powder Flow Tester (PFT) from the shipping container. To do this, cut the straps from the box and pallet.

Note: PLEASE RETAIN ALL PACKAGING MATERIALS FOR FUTURE USE.
Refer to Appendix C for packing the PFT for shipment.

2. Cut the packaging tape on the box top.
3. Open the box top and remove the accessory box.
4. Remove the top foam piece.
5. Remove the outer box by lifting it up.
6. Open the plastic bag top and slide it down to the bottom of the PFT.
7. Hand Hold locations are located on the bottom and the back of the PFT. (See Figure I-4)

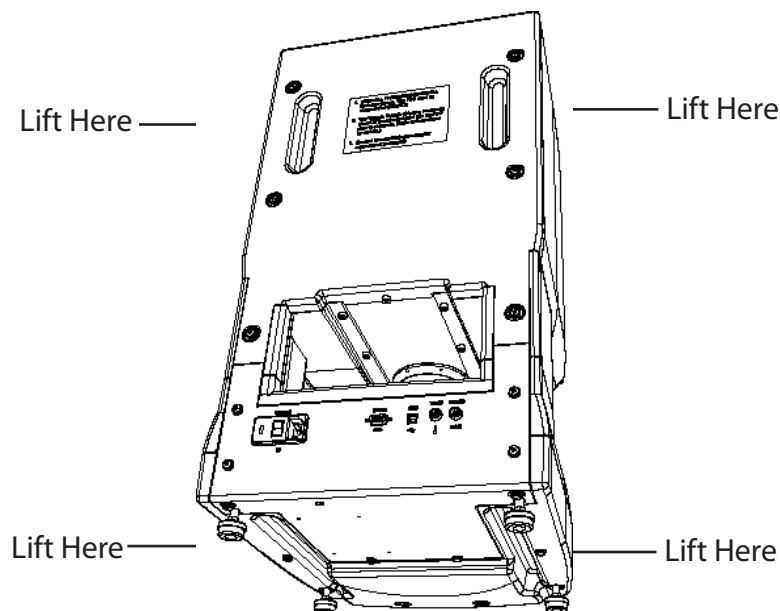

Figure I-4: Back View of Hand Hold locations

8. Lift the PFT out of the packaging by using the Hand Holds. Lift the PFT from the bottom Hand Hold and guide the PFT with the back Hand Hold.



The PFT weighs 34 kg (75 lb). Use caution when lifting the unit out of the packaging.

9. Place the PFT on a clean, sturdy and level surface.

10. **SAVE ALL PACKING MATERIALS, INCLUDING THE TROUGH FOAM INSERTS.**

11. Position the instrument so the AC power switch is easily accessible.



The AC input voltage and frequency must be within the appropriate range as shown on the model and serial tag of the instrument (located on the back of the PFT).

12. Make sure the AC power switch located in the back of the instrument is in the off position. Connect the power cord to the socket on the instrument and plug it into the appropriate AC line. Turn the power switch on.

13. Remove the horseshoe shaped foam collar (PFT-104) from the area directly above the Compression Plate.

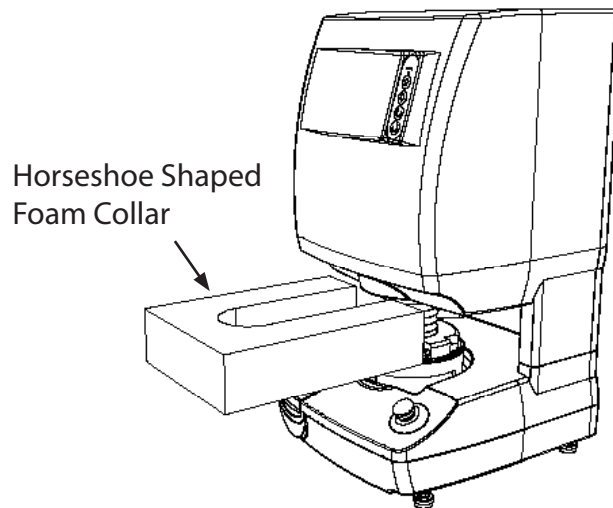

Figure I-5: Removal of foam collar

14. Press the Up arrow key to raise the Compression Plate.

15. Remove the Sample Trough by lifting it up off of the Drive Disc on the instrument.

16. Remove the foam piece in the Trough.

17. Remove any additional components from the shipping package. **Save the shipping container and packaging for future use.**

18. Connect the USB cable to the slot designated for the USB in the back of the instrument. If RS-232 is used instead of USB, connect the cable to the RS-232 slot.

19. Connect the other end of the USB or RS-232 cable to a computer.

20. The PFT must be leveled. Open the bubble level access door. Adjust the four feet until the bubble is centered within the circle of the bubble level; also check to ensure the instrument is stable. Use a 3/8" wrench (supplied in the Standard Accessory kit) or tilt the instrument to adjust the feet by hand.

I.10 Cleaning

Instrument and Keypad:

Clean with a dry, nonabrasive cloth. Do not use solvents or cleaners.
Use a vacuum cleaner to remove excess powder sample.



Do not use compressed air to clean the PFT.

Troughs/Lids/Catch trays:

These accessories are made from a variety of materials ranging from metals (stainless steel, Aluminum) to plastics (Tivar 88, Teflon). Clean with a nonabrasive cloth using solvents that are appropriate for both the sample material and the material of the accessory.



Do not apply excessive force to the compression lid assembly or the sample trough drive assembly on the instrument. Damage may occur to the components.



Some of the accessories have sharp edges.

II. QUICK START PROCEDURE

1. Level the instrument.
2. Turn on the power to the instrument. The switch is on the back side.
3. Open Powder Flow Pro software application on PC. Go to the setup tab. Establish communication with the instrument by pushing the search button. The communication or “COM” port will automatically be selected and identified.
4. Record the weight of the Trough (e.g. 702.34 grams).

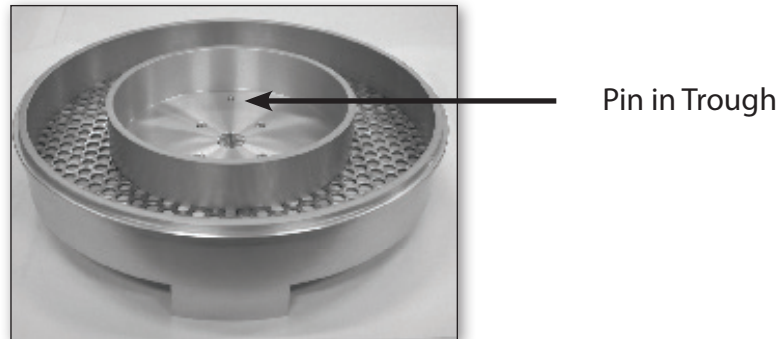

Figure II-1: Trough

5. Attach the Outer Catch Tray outside the trough. Insert the Inner Catch Tray with Shaping Blade inside the Trough. The Inner catch tray locks into place with slight rotation. The pin in the Trough engages with one of the multiple pinholes in the bottom of the Inner Catch Tray.

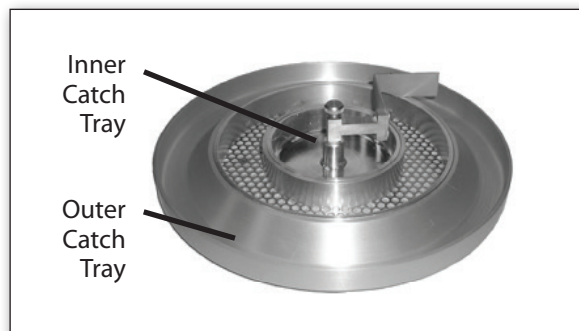

Figure II-2: Inner and Outer Catch Tray

6. Fill the Trough with powder and level with the Shaping Blade; use the Shaping Blade with a curved profile for test using a Vane Lid; use the Shaping Blade with a flat profile for test using a Wall Lid.

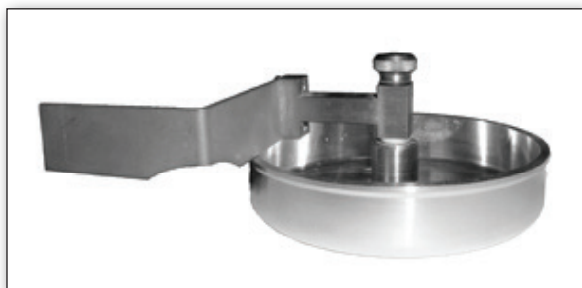

Figure II-3: Shaping Blade with curved profile

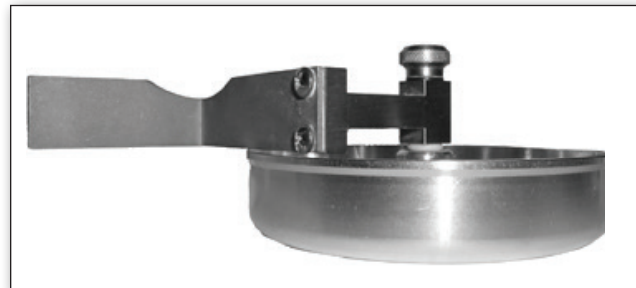

Figure II-4: Shaping Blade with flat profile

7. Remove both catch trays.
8. Record the weight of the powder and the trough. Subtract the weight of the trough to determine the weight of the sample.
9. Install the trough onto the instrument. Rotate the Trough by hand until the pinhole on the bottom of the Trough engages the pin on the PFT turntable. The Outer Catch Tray can be installed on the trough to catch spillage during the test.



II-5: Powder Flow Tester

10. Attach the appropriate Lid to the instrument. Use Vane Lid for the Flow Function test and Time Consolidated Flow Function test. Use the Wall Friction Lid for the Wall Friction test and the Bulk Density test.



Figure II-6: Vane Lid



Figure II-7: Wall Friction Lid

11. Go to the Powder Flow Pro software application. Enter the sample information and the weight of the powder sample under the tests tab. This information cannot be changed once the test has started.

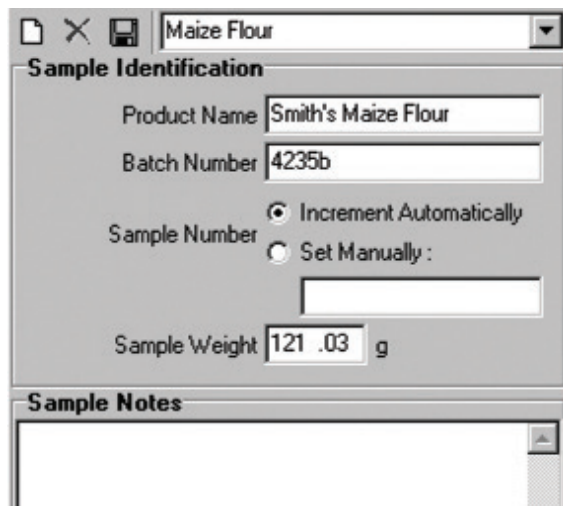

Figure II-8: Sample Identification and Test Selection

12. Select the desired test method, e.g. Standard Flow Function. The default settings for the number of Consolidation Stresses (5) and number of Over Consolidation Stresses (3) will automatically appear. "Geometric Spacing" for the Consolidation Stresses is the default setting for Standard Flow Function.

Push DISPLAY TEST STRESSES button for a detailed list of the test steps.

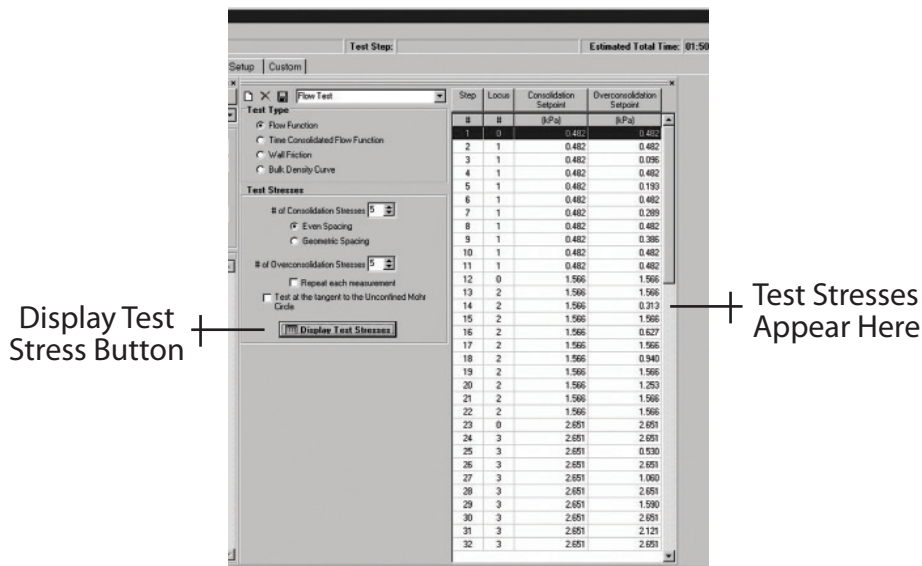

Figure II-9: Flow Function Test

13. Start the test by pushing the RUN TEST button. The lid will move downward to the position above, but not touching the sample. The instrument performs an automatic check on position and lead/torque sensor condition. During this self-check procedure, the lid will bounce up and down for several seconds. When completed, the lid will move downward to make contact with the powder sample.
14. The Analysis Tab becomes active during the test. The real time display shows the axial load applied to the powder used to calculate the consolidation stress, and the torsional torque measured used to calculate the failure strength of the powder. The test runs automatically to

completion. Save the test results under the file name which you selected when entering the test sample information.

15. After the completion of the test, the lid will automatically lift off of the sample. Use the manual control on the face of the instrument to raise the Lid (UP ARROW) to further raise the Lid to the top of its range. Remove Lid from instrument. Remove the Trough from the instrument. Clean off the excess powder on the instrument.
16. Clean the trough and lid.

III. SAMPLE PREPARATION AND HANDLING

Accurate and repeatable test results require attention to condition of the sample prior to testing and the use of proper laboratory procedures during sample preparation. This section explains the details.

III.1 Sample Issues

The Flow Function and Time Consolidated Flow Function Tests require slightly over 260 cc of sample material. Allowing for spillage during sample preparation and testing, best practice suggests that you start with at least 300 cc of sample material. If repeated tests will be performed on the same sample, then 500 cc or more are recommended.

Note the condition of the sample prior to testing. Storage in a bag or sealed container will offer protection, whereas leaving the sample on the counter in an open bag or container will expose the sample to the environmental conditions in the test area. If the sample has “lumps” or “clumps” of material, spread the material out in a flat pan and gently break the lumps/clumps up so that the powder is more uniform in nature. Use a spatula, spoon or scoop to accomplish the “breaking up” action. Alternately, use the PFT Sieve Kit to remove lumps/clumps. See Figure III-1.

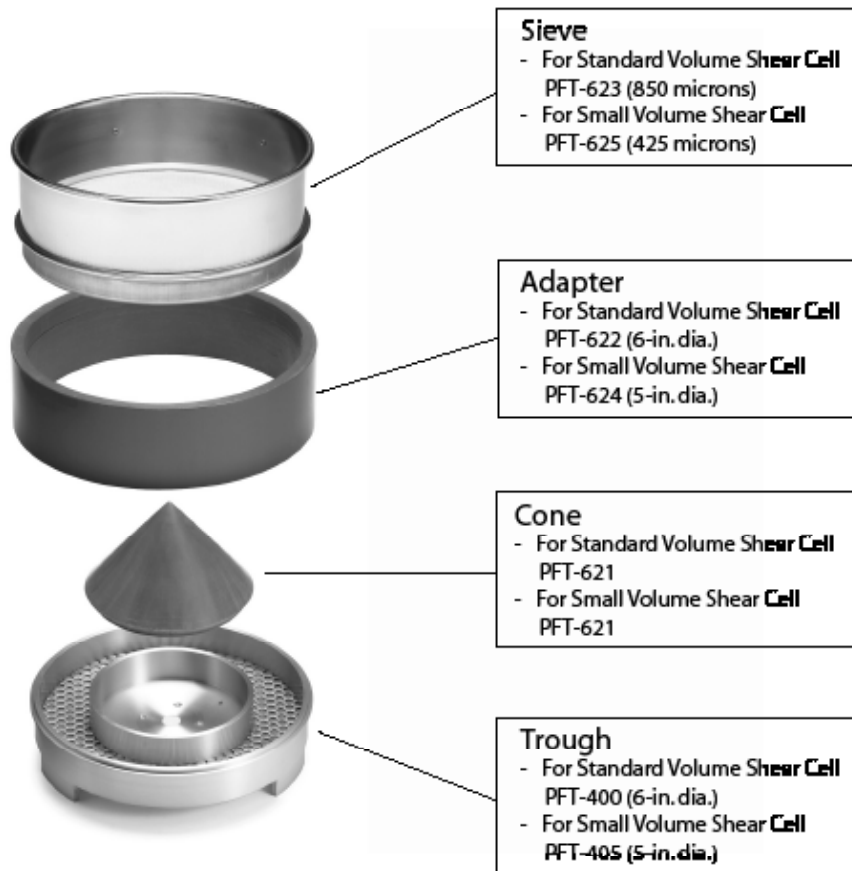

Figure III-1: Sieve Kit (separated)

Use PFT-626 with the Standard Volume Shear Cell and PFT-627 with the Small Volume Shear Cell.

Moisture in the sample is one of the primary factors to be aware of when working with powders because it can have a serious impact in making the powder more cohesive, and therefore less free-flowing. The potential for the powder to take on moisture (either by adsorption or absorption) is a factor that can affect test results. The Powder Flow Tester has the optional capability to accommodate a humidity sensor (Part No. PFT-607Y) which plugs into the back of the instrument.

Temperature may have some impact, but certainly plays less of a factor compared to humidity. The Powder Flow Tester has the optional capability to accommodate a temperature sensor (Part No. DVP-94Y) which also plugs into the back of the instrument.

Consider all environmental issues in your test area before proceeding with your test plan.

III.2 Sample Trough

There are two sizes of Troughs available for use with the PFT: The Standard Trough and the Small Sample Volume Trough.

Figure III-2 shows the Standard Sample Trough (Part No. PFT-400) which comes with the PFT. The trough is made of aluminum and is of annular shape for containment of sample. In the bottom of the trough is a Perforated Screen (Part No. PFT-440) which holds the sample in place so that the powder particles on the bottom do not slide on the smooth metal surface when the trough rotates.

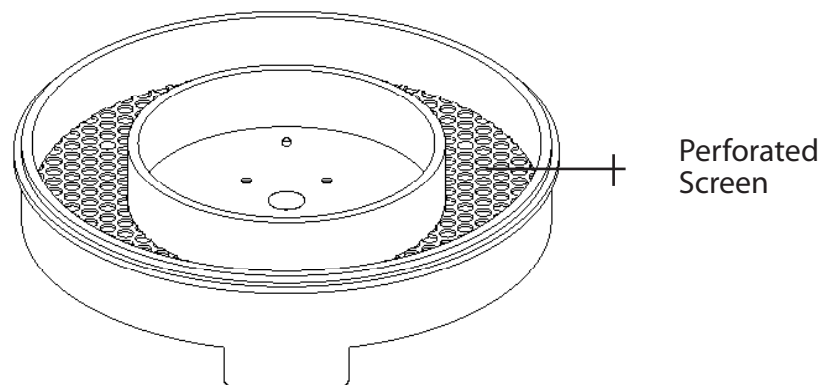

Figure III-2: Sample Trough

When the Standard Trough is filled to level, it holds 230 cc of sample material. When used with the Standard Vane Lid, the additional volume required for the Lid increases the total sample size to 263 cc of material.

The Small Sample Volume Trough (Part No. PFT-405) is of the same material as the standard trough. The Small Trough requires 38 cc of sample material when filled to level. When used with the Small Vane Lid, the total sample size increases to 43 cc.

III.3 Lid Selection

The PFT comes with two types of Lids of annular design as shown in Figure III.3. The bottom side of the Lid is shown in each case; these surfaces make contact with the powder during the test.

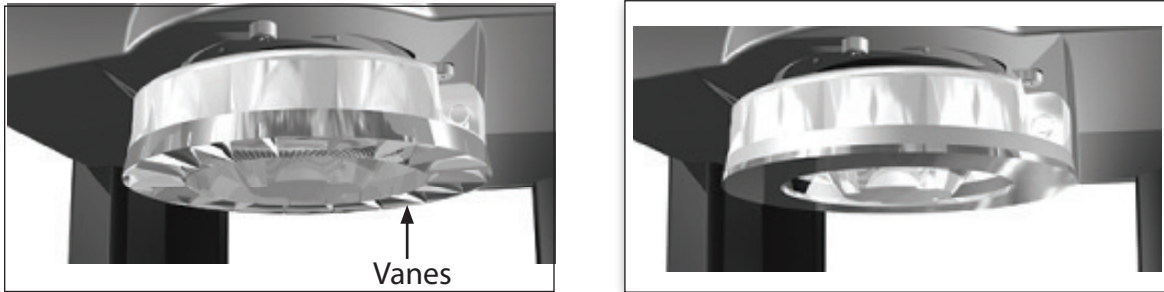

Figure III-3: Bottom side of Vane Lid and Wall Friction Lid

The Standard Vane Lid (Part No. PFT-500) has 18 small compartments which trap the powder particles and cause them to shear against the powder particles in the Trough. The Vane Lid is made of 304 s/s and has a 15.25 cm (6-inch) outer diameter. The Small Vane Lid (Part No. PFT-515) is similar in design and construction with a 12.7 cm (5-inch) outer diameter.

The Standard Wall Friction Lid (Part No. PFT-507) has a smooth bottom surface made of 304 s/s with 2B finish, which slides over the powder particles in the Trough during the test, thereby measuring the friction of powder against the surface material of the Lid. The surface can be made of other materials, depending on your preference; Mild steel (Part No. PFT-512) and Tivar 88 (Part No. PFT-513) are two other common options. The choice typically depends on the material of construction that will be used in the storage bin, hopper or containment vessel that stores the powder in your processing plant. Contact Brookfield or your authorized dealer for alternative choices on the surface material of construction for the Wall Friction Lid. The Small Wall Friction Lid (Part No PFT-516) is also available in Mild steel (Part No. PFT-522) and Tivar 88 (Part No. PFT-520).

The top sides of the Lids have two pins which engage with the Compression Plate on the instrument during the attachment process. Align the pins with the holes on the compression plate and press up to attach. Two release buttons must be pressed in order to remove the Lid from the Compression Plate.

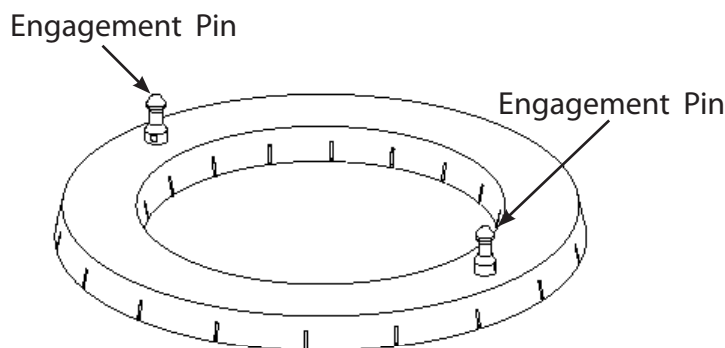

Figure III-4a: Top Side of Lid Showing Engagement Pins

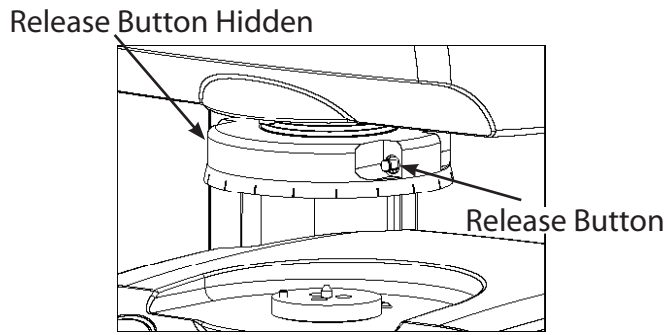

Figure III-4b: Release Buttons

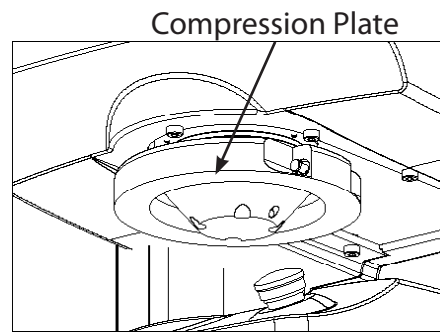

Figure III-4c: Close-up of Compression Plate Holes

III.4 Outer Catch Tray

The Outer Catch Tray, shown in Figure III.5, provides a convenient apron around the trough for collection of sample material which spills over the edge of the trough during sample loading and test execution. Center it over the trough and observe that it fits conveniently on the outer lip of the trough. This applies to both the Standard and the Small Sample Volume Troughs.

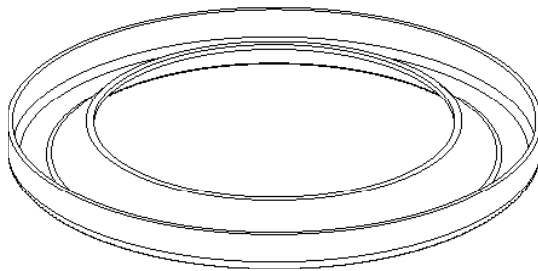

Figure III-5a: The Outer Catch Tray by Itself

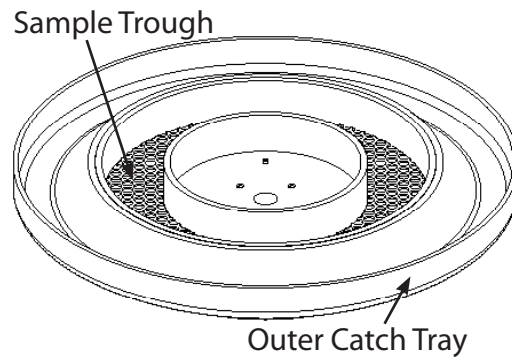

Figure III-5b: Outer Catch Tray on the Trough

III.5 Inner Catch Tray with Shaping Blade

The Inner Catch Tray is used to distribute the sample evenly in the trough. It fits into the annular opening on the trough. See Figures III-6a and III-6b.

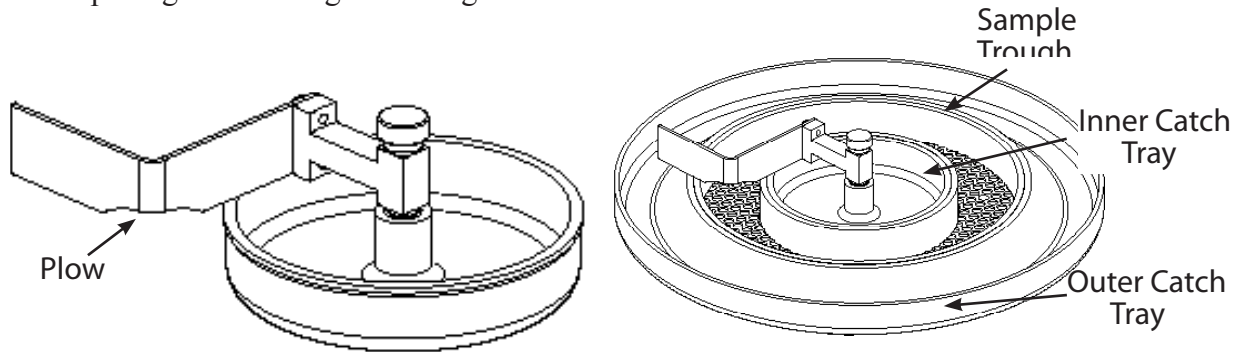

Figure III-6a: Inner Catch Tray with Shaping Blade in Position to use Curved Profile

Figure III-6b: Inner Catch Tray Inserted Into the Annular Opening of the Trough

The Shaping Blade, which is affixed to the center of the Inner Catch Tray, is rotated by hand to distribute the sample. Note that the Shaping Blade can be removed by unscrewing the thumb screw that secures it to the Inner Catch Tray. This allows the user to choose the type of scraper blade that is needed for sample distribution. Note that one side of the Shaping Blade is flat (for use with Wall Lid in the Wall Friction and Bulk Density tests) and the other is curved which permits mounding of the sample in the trough (for use with the Vane Lid in the Flow Function and Time Consolidated Flow Function tests). See Figure III-7.

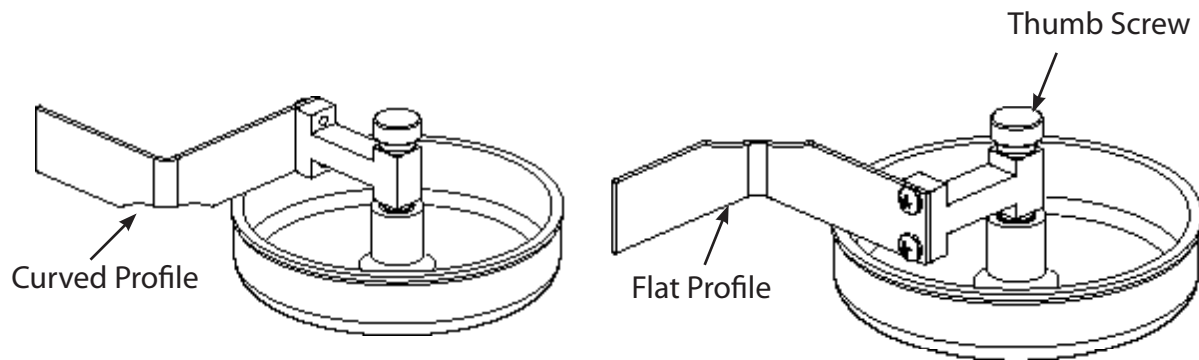

Figure III-7a

Figure III-7b

Figures III-7a and III-7b Show the Two Positions of the Shaping Blade

III.6 Loading the Trough with Sample

NOTE: Be sure the Outer and Inner Catch Trays are removed.

Weigh the Trough before filling it with sample material. Record the value.

Place the Outer Catch Tray into position on the trough. Place the Inner Catch Tray into position on the trough, this will lock into place when properly seated. Use the Powder Scoop (Part No. PFT-611), which comes with the instrument, to place the powder sample in the Trough. Any spillage is conveniently captured by the Inner and Outer Catch Trays. When sufficient sample has been placed in the trough, rotate the Shaping Blade on the Inner Catch Tray to distribute the sample evenly around the trough. Rotate in a clockwise direction until the sample is completely distributed. Then rotate in a counter-clockwise direction to remove excess sample.

An alternate loading procedure was explained earlier in Section III.1 when the Sieve Kit is used. Repeat the steps in the preceding paragraph once the Trough is full with powder.

Remove the Inner and Outer Catch Trays from the trough. Return excess sample material in the Catch Trays to the container from which the powder came or throw it away in accordance with your lab policy.

III.7 Placement of the Trough and Lid on the Instrument

Take the trough loaded with sample material and weigh it again. Subtract the weight of the Trough to obtain the weight of the sample material. Enter this value into the Sample Information section of the main screen on the Powder Flow Pro software.

Make sure that the Compression Plate on the instrument is in the upmost position. Use the Up arrow on the instrument control panel to reposition the Compression Plate if necessary. Place the trough on the Drive Disc of the instrument so that the center of the trough aligns with the pin in the center of the Drive Disc. Rotate the trough by hand until the pin on the outer edge of the Drive Disc engages one of the holes on the bottom of the Trough's outer edge. When this occurs, the trough will lie secured in a flat position, centered on the drive plate.



Take care not to disturb sample.

Place the Outer Catch Tray in position around the trough. This serves to catch any spillage of the sample material when the test is running.

Attach the appropriate lid to the Compression Plate on the instrument. You may choose to do this before placing the trough on the instrument. It is simply a matter of operator preference.



The Lids are sharp. Be careful when installing and removing.

The test is now ready to begin. Refer to the section on Powder Flow Pro Software for details on running tests from your PC. When the Run Test button is pushed on the main screen, the Lid will automatically descend onto the Trough, pausing for a brief period of time just prior to making contact with the powder sample in order to perform an autozero.



Be sure to clean pins of the lids and compression plate to ensure proper alignment.

III.8 Removal of Trough and Lid from Instrument

When the test is complete, the Lid will automatically raise up a small distance off of the trough. This is a visual indication that the test has ended. Push and hold the UP arrow on the instrument control panel until the Lid has raised to its upmost position. Then disengage the Lid from the Compression Plate by pressing the release buttons (See Figure III-3b). Clean the excess powder that clings to the Lid.

Remove the Outer Catch Tray from the trough and dispose of the excess powder in the Tray. Remove the trough from the instrument and dispose of the powder sample in accordance with lab procedure. Clean the Trough with the Cleaning Brush (Part No. PFT-612) which came with the instrument.

Note that the perforated screen may require special attention with powder particles that have been trapped in the openings. To remove the perforated screen, unscrew the three screws located underneath the trough.

III.9 Clean-up

The Cleaning Brush serves to remove excess powder from the Trough and Lid. This may be adequate for repeated testing of the same powder types where the potential for cross-contamination between samples is not really an issue. Be sure to clean pins of the lids and compression plate to ensure proper alignment.

For more thorough cleaning, the use of an air hose, water, or a cleaning solvent may be desired. When using a liquid for cleaning, make sure to dry the Trough and Lid thoroughly so that moisture contamination does not become an issue with the next sample.



Do not use compressed air to clean the PFT.

IV. POWDER FLOW PRO SOFTWARE

Powder Flow Pro Software (Part No. PFT-630, available for free download on the Powder Flow Tester page on www.brookfieldengineering.com) and a USB cable for connection to a PC are provided with the PFT in order to operate the instrument, collect data, perform analyses, store data files, and export data to Excel™.

Connect the USB cable to the PFT and to your PC. Turn on the PFT using the power switch on the backside of the instrument. Once the PFT is on, start the software by clicking the Powder Flow Pro icon on the start/program bar.

IV.1 Main Screen and Setup Tab

Upon startup, the Tests Tab screen comes up as shown in Figure IV-1.

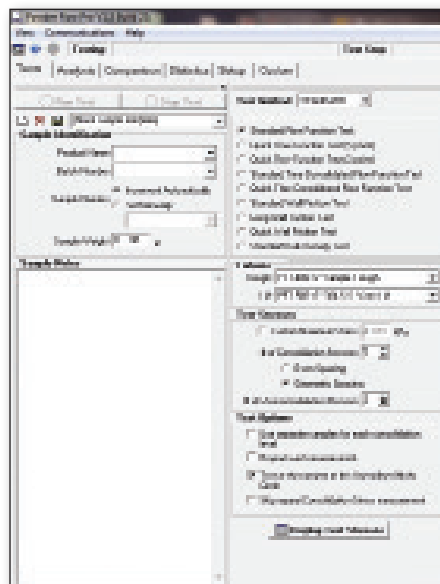

Figure IV-1: Tests Tab Screen

Details on sample type and test method are entered on this page. However, before proceeding, make sure that the program is communicating with the PFT by clicking on the Setup Tab. The Setup Screen is shown in Figure IV-2.

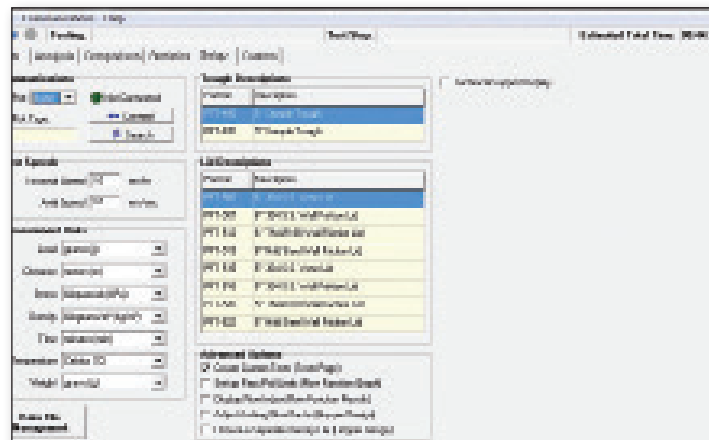

Figure IV-2: Setup Screen

Press the “Search” button. You can also select “Search” from the communications drop-down box. If the instrument is correctly connected to your PC with the USB (or RS-232) cable, the green light will come on and the type of communication port being used will be identified, in this case, USB.

While on this page, it is also possible to adjust the measurement units, axial speed for moving the lids up and down, and torsional speed for rotating the trough. Default values are set at the factory for measurement units and operating speeds. If you decide to change any of these values, you must then shut down the Powder Flow Pro program and start it up again in order for the changes to take effect.

The setup tab also contains the different lid descriptions and part number to help correctly choose the lid that fits the test being run. The lid can be changed in the Test Tab under “Test Options”.

Click the Tests Tab, which brings you back to the Main Screen.

IV.2 Sample Information

The left column on the Main Screen is used to enter information on the sample that you are testing. See Figure IV-3.

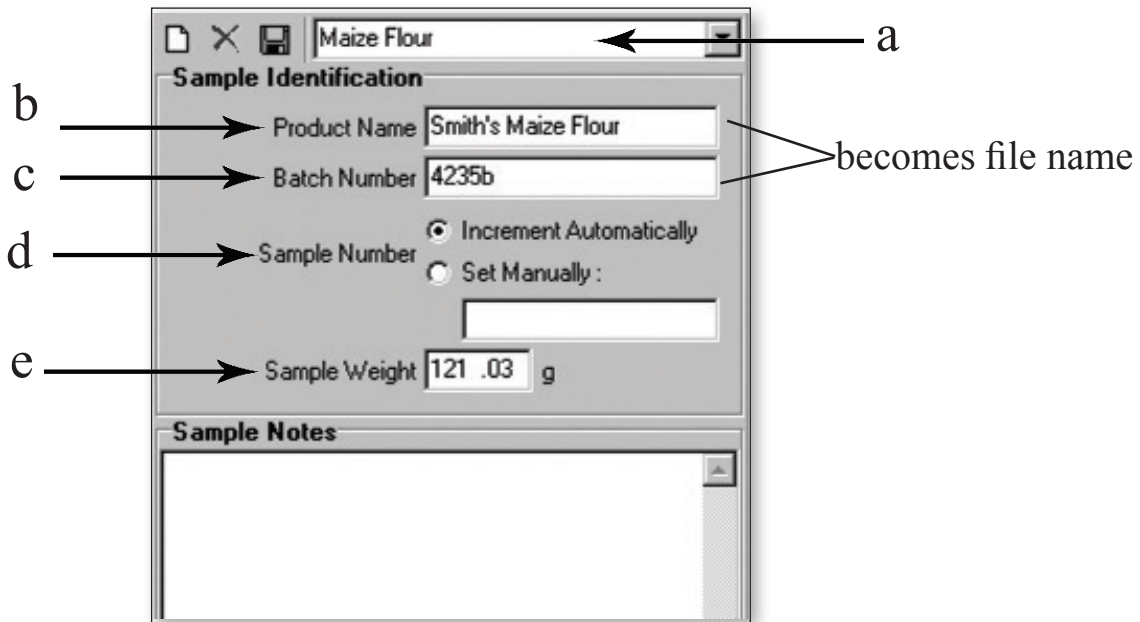

Figure IV-3: Close-up of Left Column on Main Screen

There are 5 boxes in which to make entries:

- Sample Template E.g. Maize Flour
- Product Name E.g. Smith's Maize Flour
- Batch Number E.g. List your control number for the sample or, perhaps, the date time if you don't use control numbers.
- Sample Number: You have the choice to allow the software to increment each test with a sequential control number (the default setting), or you can choose to set this value by clicking the “Set Manually” button.
- Weight: Enter the weight of the sample. The default setting is grams.

Sample Notes can be entered in the box on the bottom half of the left column on the Main Screen. This may provide information, for example, on how the sample was prepared or how long it has been in storage.

Click on the disc icon above “Sample Identification” to save the information that you have just entered on your sample. This creates a sample template that can be used for future tests with the same information.

IV.3 Standard Test Method

This is the Default Test Method.

The middle column on the Tests Screen is used to select the type of test that you want to run. See Figure IV-4. The default setting when first using the Powder Flow Pro software is “Standard” for the test Method.

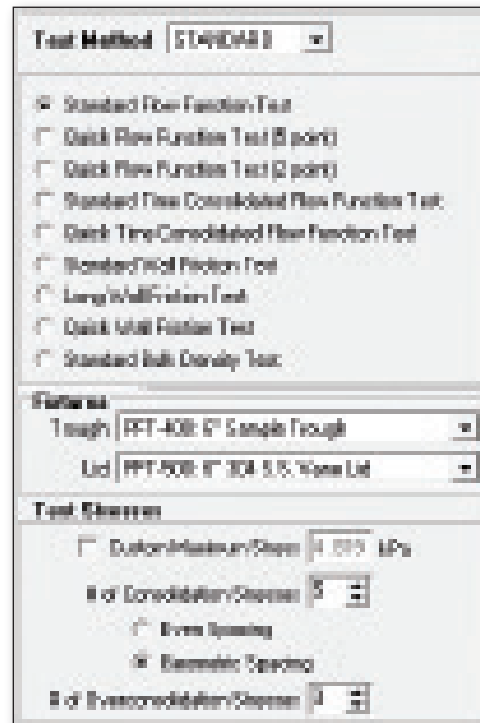

Figure IV-4: Close up of Middle Column on Main Screen

Choose one of the tests. The first five tests require the use of the Vane Lid. The last four tests require the use of the Wall Friction Lid. The first five tests pertain to Flow Function, the next three to Wall Friction and the final one to Density.

The advantage to using “STANDARD” test is that each method follows generally accepted practice in industry for evaluating most materials. The resulting data will be a fair representation of the flow behavior of the material and/or the density as a function of consolidation. Specific choices for test parameters are not necessary because these values have automatically been built into the test and cannot be changed.

IV.3.1 The Flow Function Test

The Standard Flow Function Test employs 5 Consolidation Stresses using Geometric Spacing between each stress, 3 over consolidation stresses at each consolidation stress, and one special consolidation stress for the test at the tangent to the Unconfined Mohr Circle. (See the Help file in the software for additional detail on this last statement.)

The Standard Flow Function Test runs 35 test conditions on one sample, to explore fully the complex behaviour of a powder. This gives the highest level of confidence in the relevance of results when comparing different powders. It is in line with long-established protocols. Brookfield recommends the Standard Flow Function Test as the best test to use when obtaining powder flow data for comparing powder behaviour, for Quality Control purpose, for equipment design/assessment or any other purposes, provided you can spare the time to run it (around 34 minutes).

The Quick Flow Function Tests (5-point and 2-point) have been developed to give faster tests (18 minutes and 14 minutes respectively) for users who cannot spare the time to run the Standard Flow Function Test and are happy with a less sensitive comparison between powders. They measure fewer test conditions (total of 6 for the 2-point and 15 for the 5-point test) so the results do not capture the full behaviour of the powder. Where the powders are more than about 10% different from one another in flowability, these short tests will give useful indicative comparisons, but for powders that are fairly close in behaviour, the differences may not be apparent.

Do not attempt to compare Flow Functions obtained from different tests (E.g. 2-point against standard, or 5-point against 2-point) because the comparison is likely to be incomplete.

The Quick Flow Function Tests are excellent for doing a first-stage screening if you have a large number of powders and you wish to quickly bracket them into groups by flow properties (say to find the ones that are most likely troublesome and deserve more detailed measurements). Even the 2-point test will reliably indicate where there are substantial differences in behaviour between powders. Some users find they can use the 5-point test for Quality Control purposes, to identify batches within a single production stream that could be troublesome. However, if you wish to use the “quick” tests for QC, Brookfield recommends a investigation in which you run the Standard, 5-point and 2-point tests in parallel on a substantial number of production samples to ensure that the quick test does indeed identify any differences that you consider significant. Once you have satisfied yourself that this is the case, then always use the same test (Standard Flow Function, 5- or 2-point Quick Flow Function) for that QC procedure. Do not be tempted to compare data between the three test types. As a general rule, the smaller the differences you are looking to discriminate, then the larger the number of test points you will require.

Once the test has been selected, click on the “Display Test Stresses” button to view the number of steps in your program as shown in Figure IV-5. In this case a standard flow function test has been selected. The two columns on the right show the sequence for the consolidation stresses and the corresponding overconsolidation stresses that will be applied. Note that the time estimate for the test to run is displayed in the window at the top right of the Main Screen. Units are hours:minutes:seconds.

Estimated Total Time: 00:37:55			
Step	Locus	Consolidation Setpoint	Overconsolidation Setpoint
#	#	(N/m ²)	(N/m ²)
1	0	289	289
2	1	289	289
3	1	289	96
4	1	289	289
5	1	209	193
6	1	289	289
9	1	289	289
10	0	584	584
11	2	584	584
12	2	584	195
13	2	584	584
14	2	584	390
15	2	584	584
18	2	584	584
19	0	1181	1181
20	3	1181	1181
21	3	1181	394

Figure IV-5: Right Column on Main Screen

IV.4 Custom Test Method

To create custom tests, the test method must be changed to CUSTOM in the “Test Method” tab shown in Figure IV.4. To enable this custom test method, you must choose this from the advanced options under the Setup tab (see Section IV.9 to select custom tests).

The screenshot shows the 'Custom Test Method' configuration screen. It includes the following sections:

- Test Method:** A dropdown menu set to 'CUSTOM'.
- Test Type:** Radio buttons for 'Flow Function', 'Time Consolidated Flow Function', 'Initial Friction', and 'Bulk Density Curve'. 'Flow Function' is selected.
- Parameters:** Two dropdown menus for 'Trough: PFT-100 of Sample Trough' and 'Lid: PFT-500 of 304 S.S. Vane Lid'.
- Test Settings:**
 - Custom Maximum Stress: 1.015 kPa
 - # of Consolidation Strokes: 2
 - Even Spacing
 - Geometric Spacing
 - # of Overconsolidation Strokes: 1
- Test Options:**
 - Set vertical variable for each consolidation level
 - Repeat each measurement
 - Test at the largest of the Unconfined Mohr-Circle

Figure IV-6: Custom Test Method Screen

Details on information that you must enter for each test follow:

a) **Flow Function**

The user can set the maximum in consolidation stress to test to, the number of consolidation stresses to test, whether to space the consolidation stresses evenly or geometrically, the number of over consolidation stresses to run at each consolidation stress, whether to use a new sample for each consolidation test, whether to repeat each stress measurement, and whether to test at the tangent to the Unconfined Mohr Circle.

b) **Time Consolidated Flow Function**

The user can set the amount of time to consolidate at each consolidation step, whether to use a new sample for each time consolidation, the maximum consolidation stress to test to, the number of consolidation stresses to test, whether to space the consolidation stresses evenly or geometrically, the number of over consolidation stresses to run at each consolidation stress, what stress to apply during time consolidation, whether to repeat each stress measurement, and whether to test at the tangent to the Unconfined Mohr Circle.

c) **Wall Friction**

The user can set the material of the wall lid, the maximum stress to test to, the number of displacement levels to test at, whether to space the displacement levels evenly or in a doubling progression, the number of stresses to run at each displacement level, what stress to apply during wall displacements, and whether to use a new sample for each displacement level.

d) **Bulk Density Curve**

The user can set the number of stress setpoints and the maximum stress to test to.

Click on the disc icon above “Test Type” to save the information that you have just entered on test type. This creates a template that saves the test procedures for future use.

IV.5 Test Execution

To start the test, click the “Run Test” button on the Main Screen. The Lid will descend to a position slightly above the sample in the Trough; the instrument will perform an autozero; then the Lid will make contact with the sample and the test begins.

The Raw Data Tab on the Analysis Screen will automatically come up and show the axial load test data and the torsional load test data. See Figure IV-7 for an example of the raw data generated during a flow function test. The axial load units are shown on the Y-axis on the left of the graph (red color) and the torsional load units are shown on the Y-axis on the right of the graph (blue color). The axes can be changed to the user’s preference by using the drop down boxes above the graph.

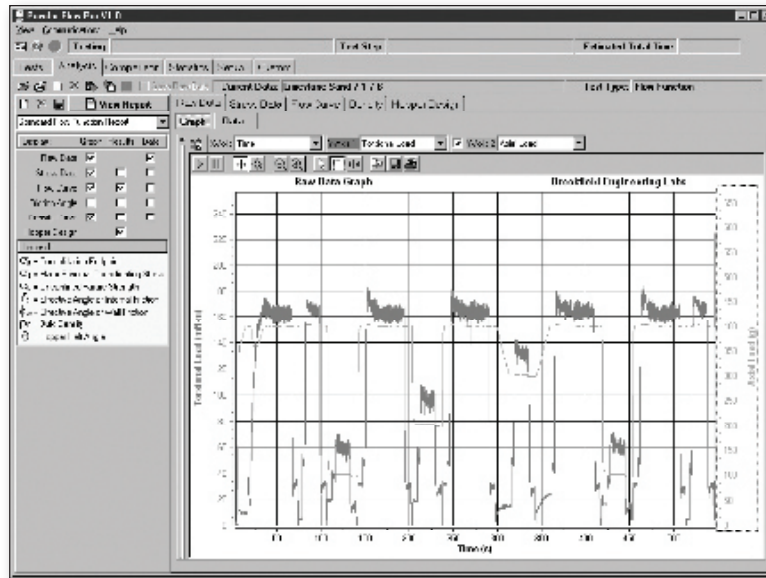

Figure IV-7: Image of Test Data on Analysis Screen Showing One Full Cycle of a Consolidation Stress and Four Associated Overconsolidation Stresses

Throughout the test, a green light will flash and the estimated time to completion will continue to count down and be displayed in the top right window on your screen. The algorithms which measure peak torsional stress and steady state torsional stress have optimization functions built into the real time data analysis. The net result is that some of the test time may be reduced because the steady state value is achieved earlier than the allotted test time for a specific step(s). Alternately, the test time may increase for the opposite reason, most notably in the Flow Function Test when establishing “critical consolidation” at the beginning of each consolidation level.

At any time during the test, the user can return to the Main Screen to observe the detailed test step display and note which step is in progress.

When the test is completed, the flashing green light will disappear, the “Estimated Test Time” window will be blank, and the Lid will raise up slightly off the sample. The test step will say “Test Complete”.

Details on test method execution for each of the 4 test types are shown in the following figures.

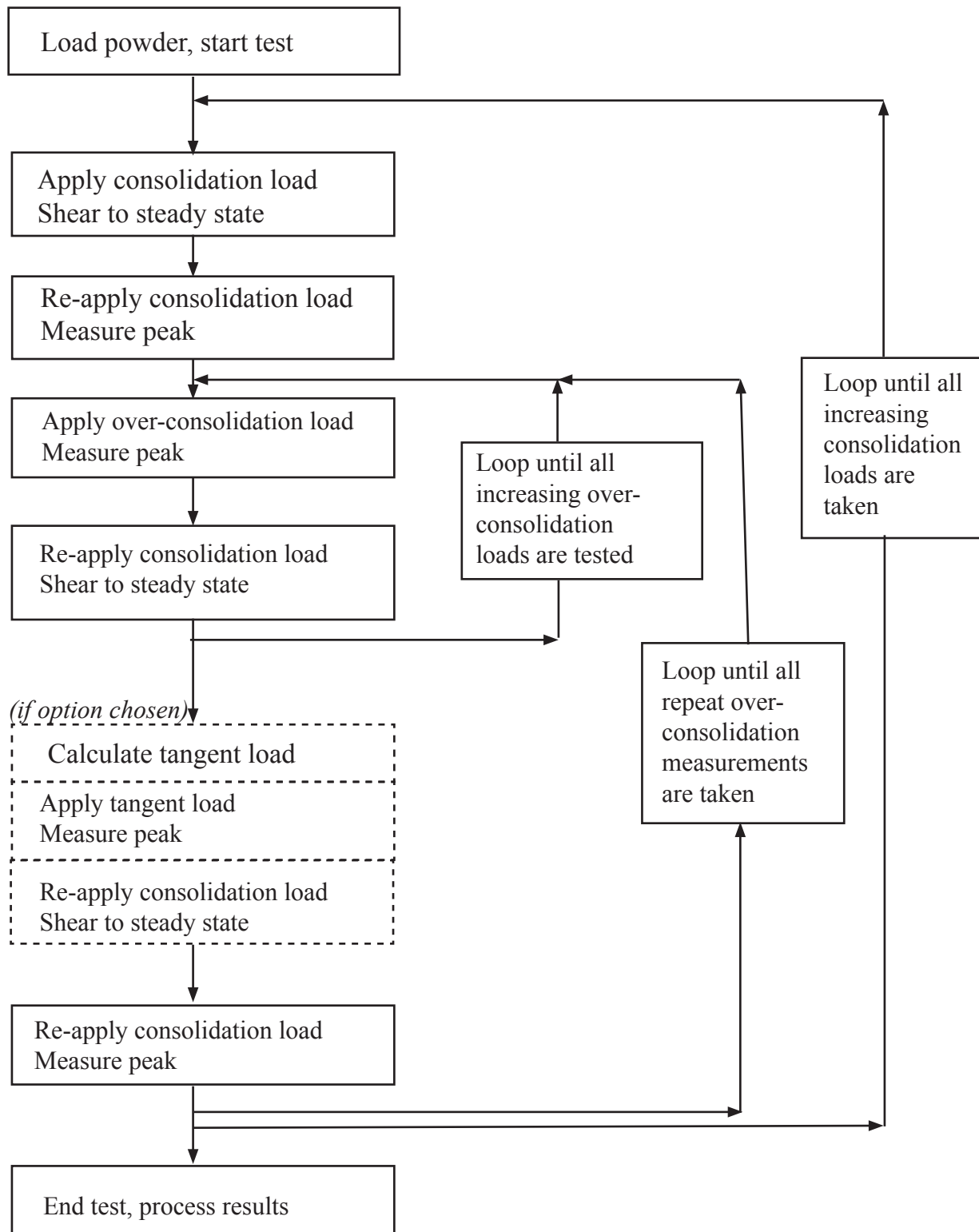

Figure IV-8: Flow Function Test Algorithm.

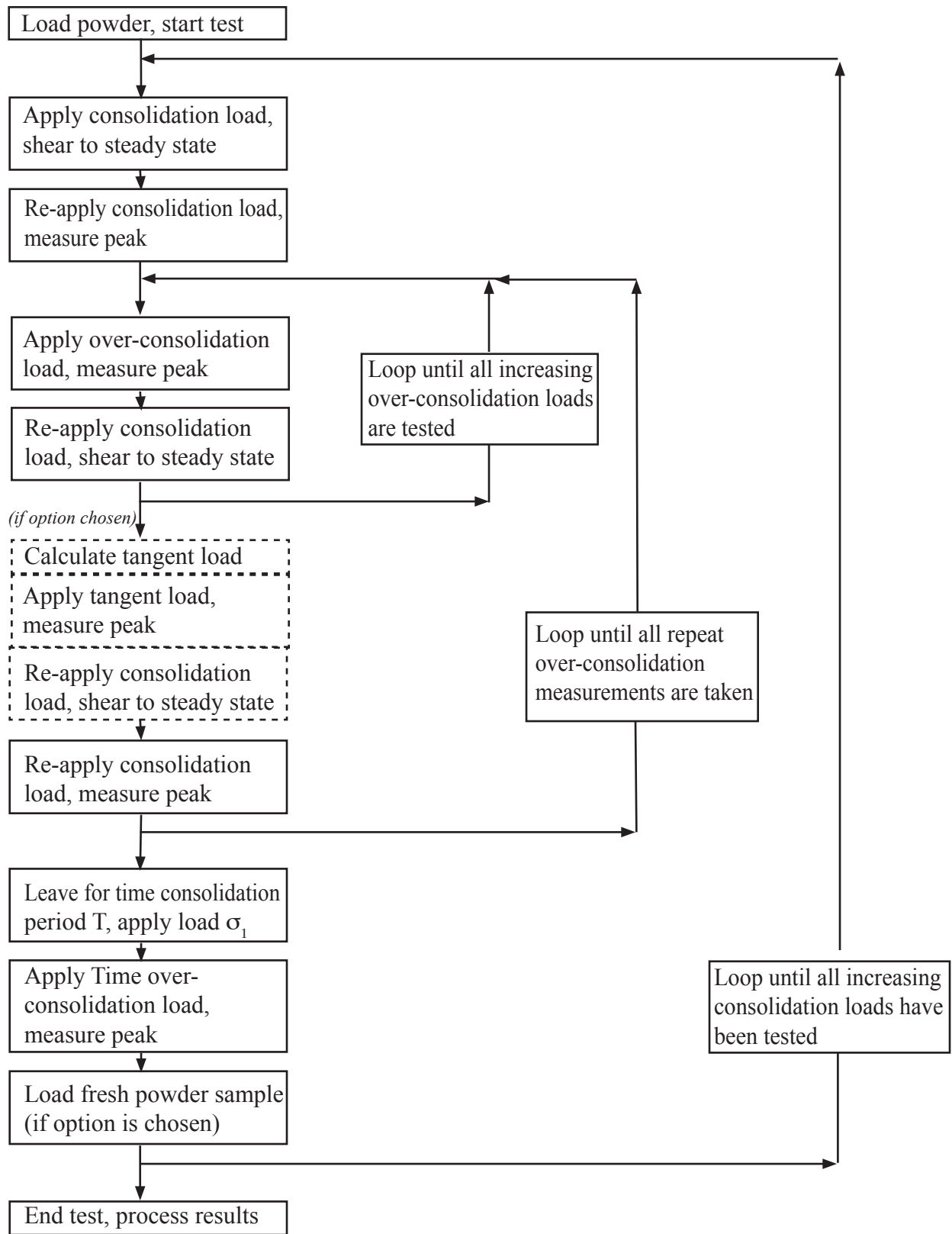

Figure IV-9: Time Consolidated Flow Function Algorithm

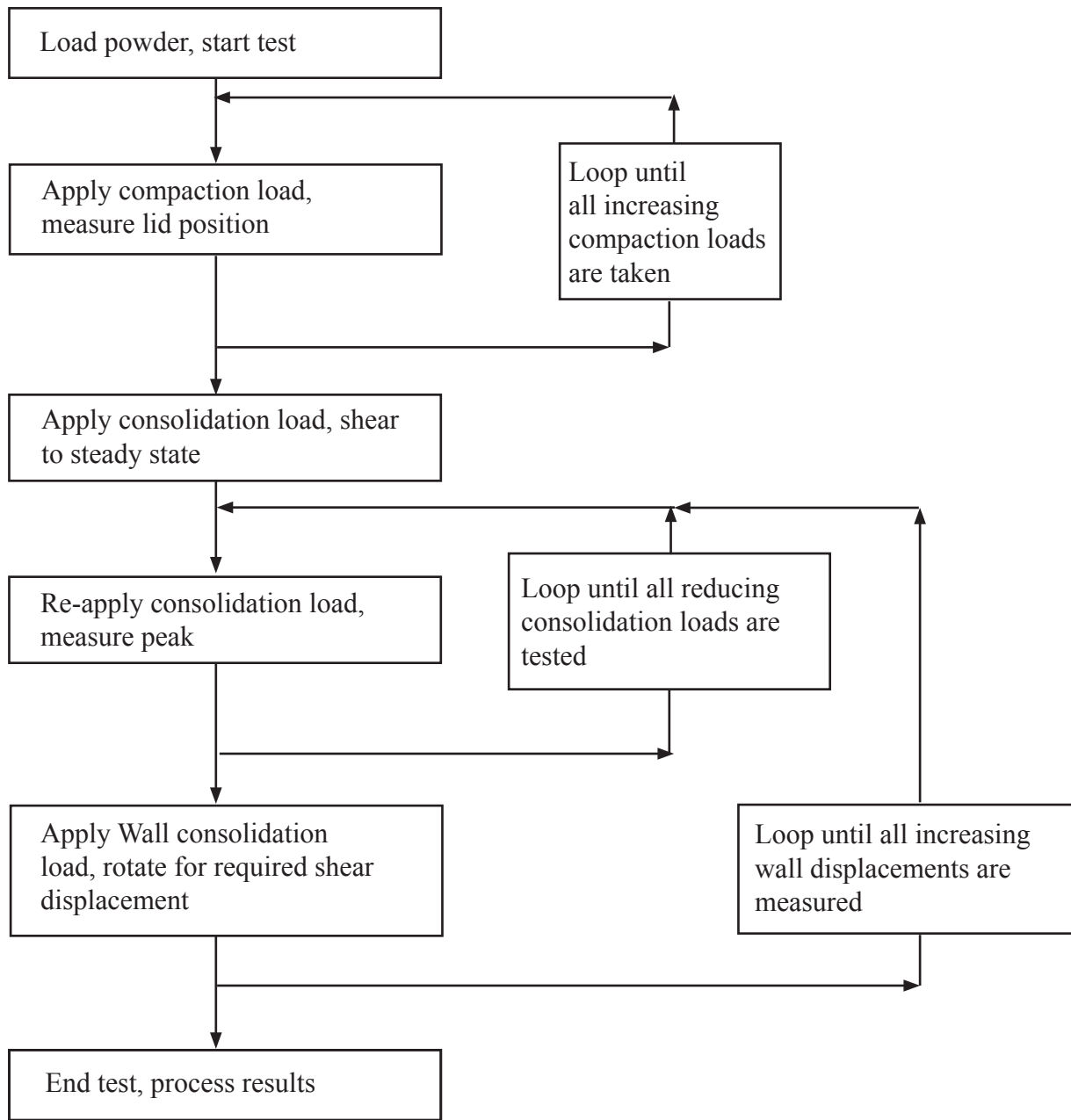

Figure IV-10: Wall Friction Test Algorithm

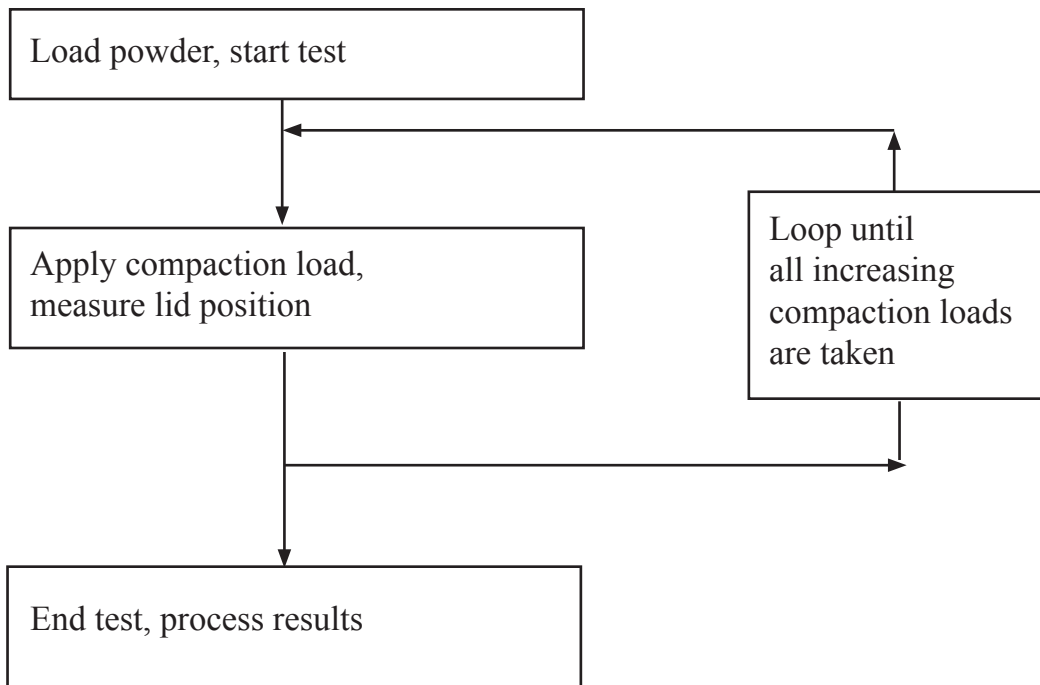

Figure IV-11: Bulk Density Test Algorithm

IV.6 How to Stop the Test



In case of an emergency, hit the large red Test Stop Button on the instrument and use the manual control keys to reposition the lid and trough as necessary. (See section I.7 for more information.)

In non-emergency situations, the user can abort the test by clicking on the Stop icon in the upper left corner of the main screen or by clicking the Stop Test button, which lights up on the Main Screen once the test starts. See Figure IV-12.

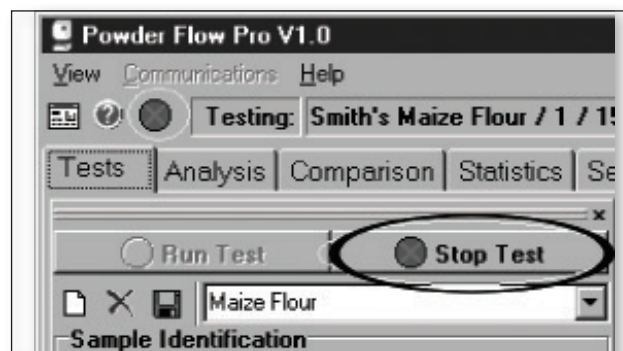

Figure IV-12: Stop Button on the Analysis Screen

When the Stop Test button is clicked, the Lid will lift up from the Trough, which is no longer rotating. The test is cancelled and cannot be resumed at the step where it was stopped. If the sample had been compacted, it is best practice to replace the sample with fresh material before starting a new test.

IV.7 Analysis Section

IV.7.1 How to Save Data

Once the test has completed, you have the choice to save the raw test data and/or the calculated stress data (click on the Stress Data Tab). Most users will choose to save only the calculated stress data, since this is the basis for computing the desired output parameters: flow function, friction angle curves, density curve and critical hopper dimensions.

The raw test data consists of 50 data points per second, which means that the file size can be large, especially for tests of lengthy duration. For this reason, most users may choose not to save raw data.

To save the calculated stress data, click the disk icon on the toolbar. To save the raw data, click the box called "Save Raw Data" located next to the disk icon, then click the disk icon; this will save both the raw data and the calculated stress data.

The graph may be saved separately as a bitmap by clicking the disc icon above the selected graph. To get the desired picture, the buttons above the graphs can be used to zoom in, zoom out, as well as scroll the axis. Right clicking on the axis gives the option "zoom to fit" which can be a very useful tool (for example, instead of saving the huge raw data file, the user can use the "zoom to fit" feature to fit the entire raw data sequence and then save it as a bitmap instead.).

IV.7.2 Choices for Data Display

Figure IV-13 shows the available choices for data that can be displayed (Raw Data, Stress Data, Flow Function, Friction Angle, Density, Hopper Design) and the format for displaying the data (Graph, Results, Data). Click on the boxes that you require and the corresponding data and/or graph(s) will be shown.

Display :	Graph	Results	Data
Raw Data	<input checked="" type="checkbox"/>		<input checked="" type="checkbox"/>
Stress Data	<input checked="" type="checkbox"/>	<input type="checkbox"/>	<input type="checkbox"/>
Flow Curve	<input checked="" type="checkbox"/>	<input checked="" type="checkbox"/>	<input type="checkbox"/>
Friction Angle	<input type="checkbox"/>	<input type="checkbox"/>	<input type="checkbox"/>
Density Curve	<input checked="" type="checkbox"/>	<input type="checkbox"/>	<input type="checkbox"/>
Hopper Design		<input checked="" type="checkbox"/>	

Figure IV-13: Options for Data Output Display

When the test for Bulk Density Curve is selected, the tabs which appear include Raw Data, Stress Data, and Density.

Note that the different results are available depending on the type of test that was run. The Flow Function tab applies only to Flow Function and Time Consolidated Flow Function tests. Bulk Density tests include only Raw Data, Stress Data and Density.

Details on the information that can be viewed under each tab follows:

a) Raw Data:

All test types display the specific fields chosen for the raw data graph.

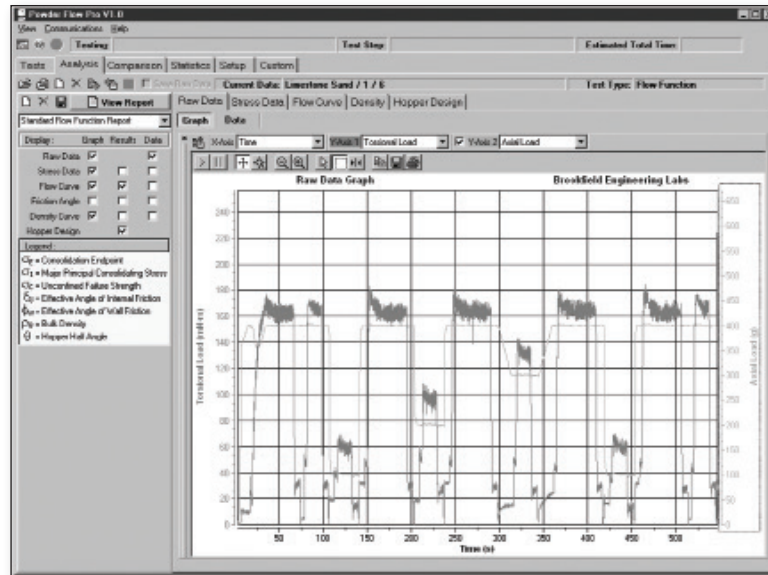

Figure IV-14: Raw Data Graph for Flow Function Test

b) Stress Data:

All applicable Peak and Steady State stresses are shown. In addition, the following is displayed for each type of test:

- Flow Function Test data shows a locus line for each Consolidation Stress setpoint, with corresponding Unconfined and Over Consolidated Mohr circles, and a Steady State locus line. For the Steady State locus, the gradient, angle, and cohesion are reported. For each Consolidation Failure Locus, the Major Principal Consolidation Stress, Unconfined Failure Strength, Angle of Internal Friction, gradient, angle, cohesion, and density are reported.
- Time Consolidated Flow Function Test data shows all the instantaneous locus lines and circles, plus a time consolidated locus line for each Consolidation Stress setpoint with its corresponding Unconfined Mohr circle. All instantaneous flow results are reported; each time consolidated locus reports its Unconfined Failure Strength and cohesion.
- Wall Friction Test shows one locus line for each Displacement setpoint and one Maximum Wall locus, including the gradient, angle, and cohesion for each locus line.
- Density Test data: Not applicable.

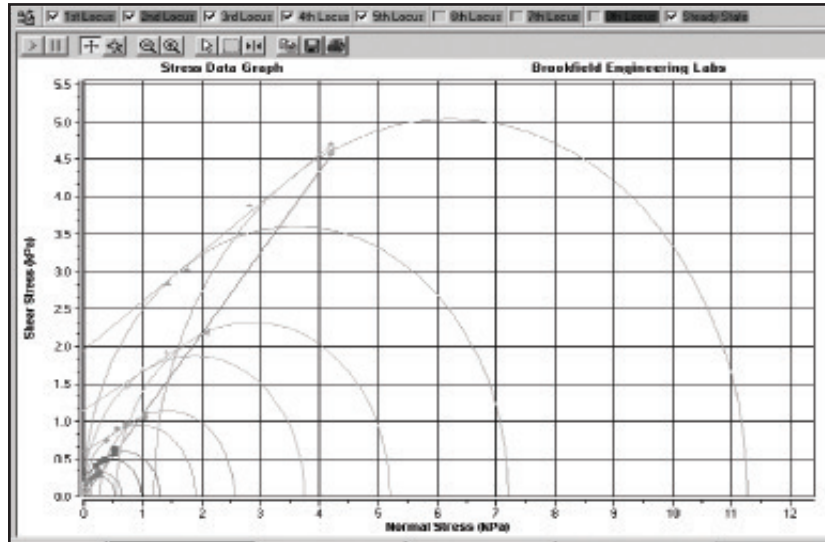

Figure IV-15: Stress Data Graph for Flow Function Test

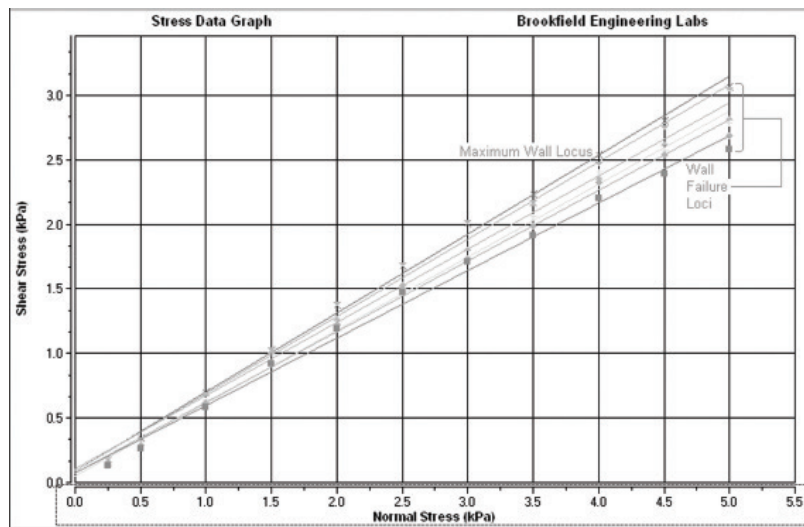

Figure IV-16: Stress Data Graph for Wall Friction Test

c) Flow Curve:

- Flow Function Test shows the curve of Unconfined Failure Strengths versus Major Principal Consolidation stress and reports the Flow Function gradient and intercept, the critical Arching and Rat-hole stress, and the Flow Index for a given stress.

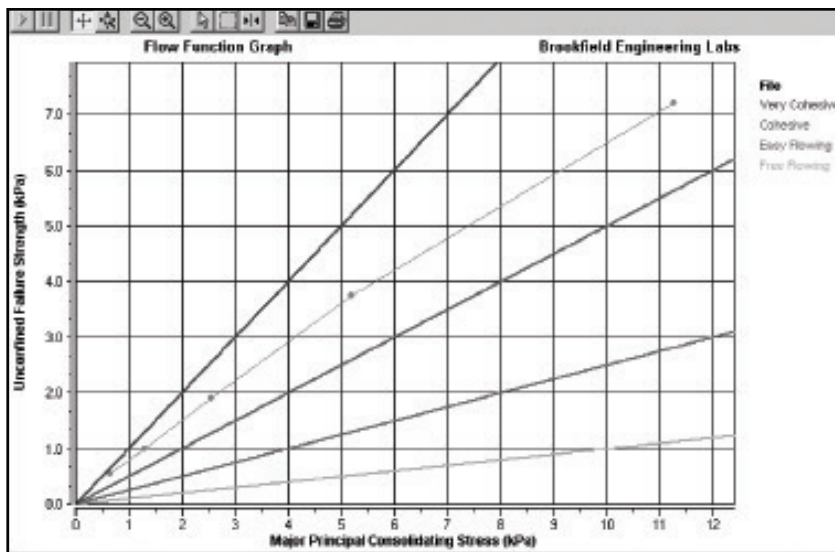

Figure IV-17: Flow Function Graph

- Time Consolidated Flow Function Test shows the same results as the Flow Function Test, but shows one set of results based on the instantaneous Flow Function and one based on the Time Consolidated Flow Function.

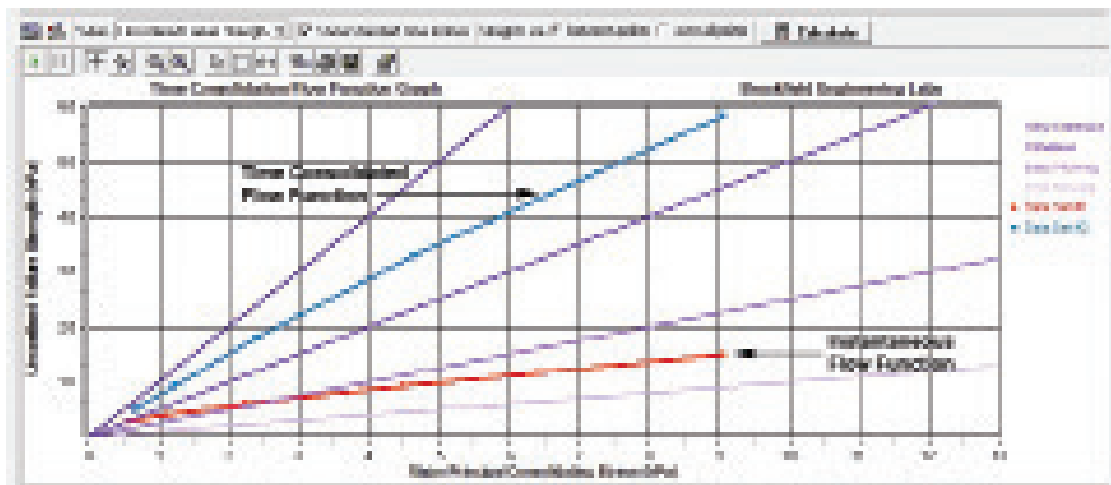

Figure IV-18: Time Consolidation Test Graph

- A graph of a “normalized” flow function is obtained by selecting Potential Arching Diameter from the drop-down list box located above the graph. The “normalized” flow function provides a means for comparing powders that exhibit similar flow function behavior, but have different density properties. The graph plots “potential arching diameter” against “major principal consolidating stress”. The mathematics involves dividing the density of the powder at each consolidation stress into the value for the unconfined failure strength.

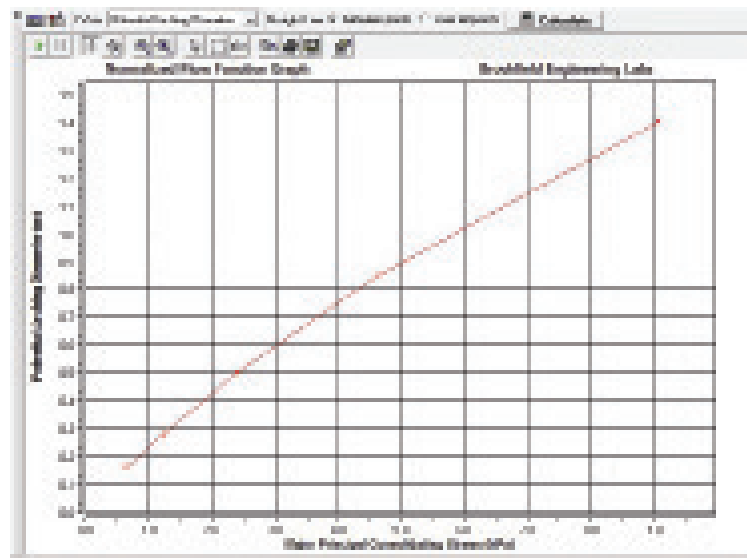

Figure IV-19: Normalized Flow Function Graph

- Flow Factor: Select the setup tab. Check the box “Display Flow Index”. A dotted line appears on the Flow Function curve under the Analysis tab. This is referred to as the “Arching Flow Factor”.

The default value for the Flow Factor is 1.4; the value can also be selected by the user and normally ranges between 1.0 and 1.8 in design practice; choosing values below 1.4 shifts the Flow Factor line to give a steeper slope; choosing values above 1.4 shifts the Flow Factor line to give a lower slope.

If the Flow Factor line intersects the Flow Function curve, this point of intersection defines the “critical consolidation stress”.

- Wall Friction Test data: Not applicable.
- Density Test data: Not applicable.

d) Friction Angle Curve:

- Flow Function Test data shows one curve based on the Effective Angle of Internal Friction for each Consolidation setpoint and reports the Effective Angle of Internal Friction for the critical Arching stress and critical Rat-hole stress.
- Time Consolidated Flow Function Test data reports the instantaneous Flow Function results along with the Effective Angle of Internal Friction for the Time critical Arching stress and Time critical Rat-hole stress.
- Wall Friction Test data shows one Wall friction angle curve for each displacement setting and one curve based on the Maximum Wall locus. The data tab lists all Wall

Friction angles, at each stress setpoint at each displacement setting, including the Maximum Wall Friction at each stress setpoint.

- Density Test data: Not applicable.

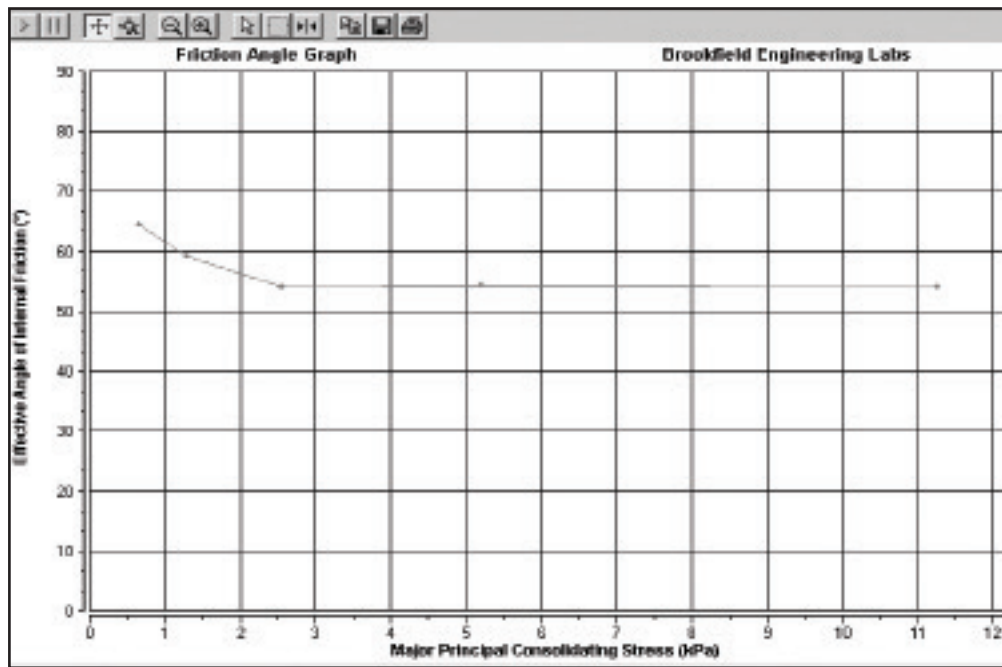

Figure IV-20: Friction Angle Graph for Flow Function Test

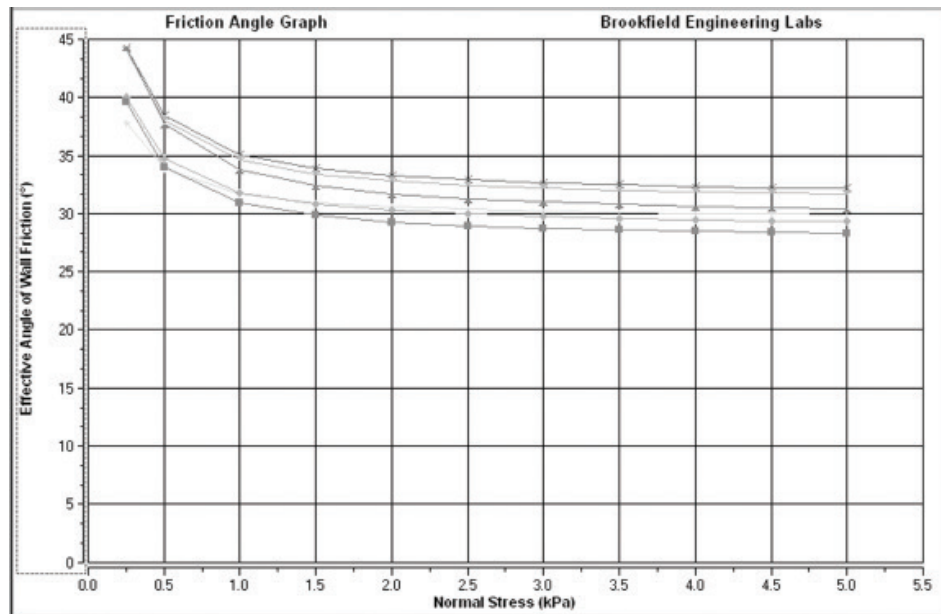

Figure IV-21: Friction Angle Graph for Wall Friction Test

e) **Density Curve:**

- Flow Function Test data shows one curve based on the initial fill density and the densities measured at the Steady State stress values. The Density for the critical Arching stress and critical Rat-hole stress are also reported.
- Time Consolidated Flow Function Test data reports instantaneous results along with the Density for the Time critical Arching stress and Time critical Rat-hole stress.
- Wall Friction Test data shows one curve based on the initial fill density and the different consolidation stresses during the test.
- Bulk Density Curve Test data shows one density curve including initial fill density.

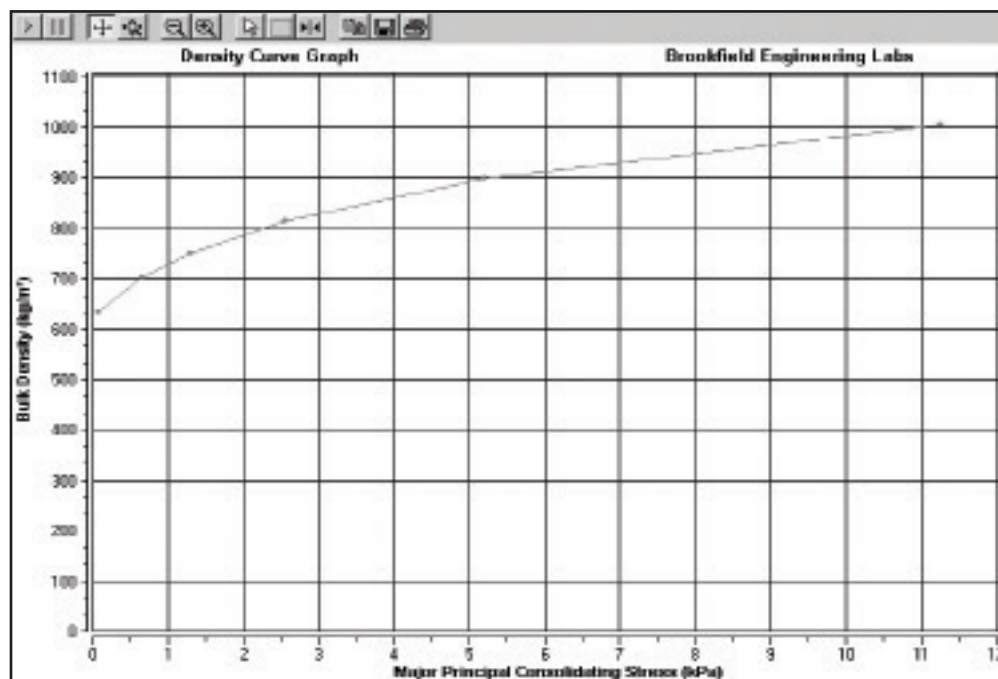

Figure IV-22: Density Curve Graph

f) **Hopper Design:**

- Single values for Arching Dimension and Rat-hole Diameter are calculated automatically using the “Critical Consolidation Stress”.
- In Mass Flow, Arching Dimension and Hopper Half Angle are calculated. A graph of hopper half angle vs. hopper outlet dimension is given. The hopper outlet dimension is equivalent to the arching dimension.

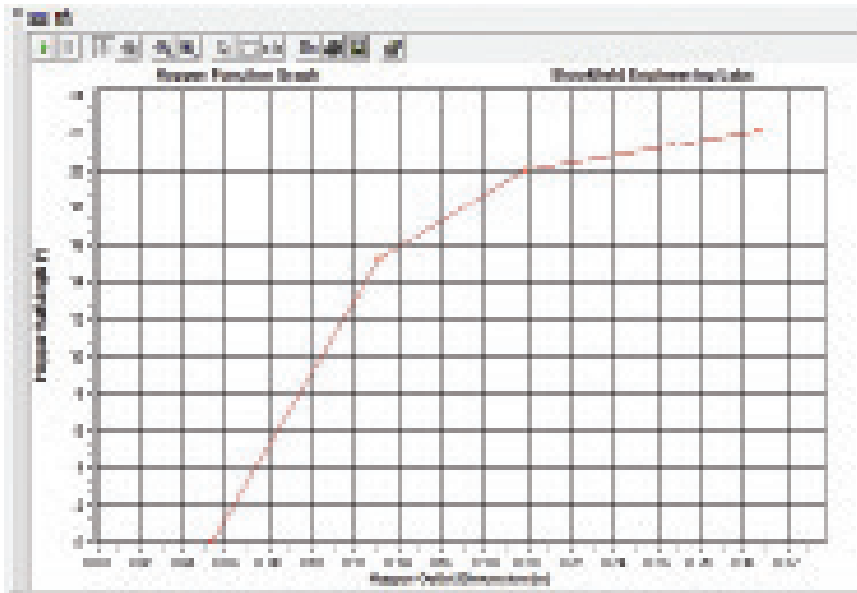

Figure IV-23: Hopper Half Angle vs. Hopper Outlet Dimension Graph

- In Core Flow, a Rat-hole Profile graph is generated showing powder depth vs. rat-hole diameter.

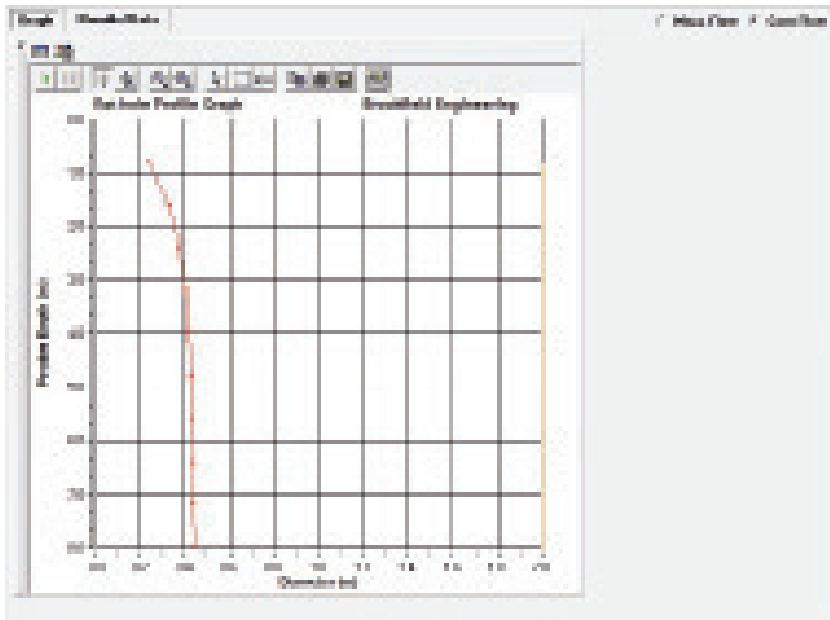

Figure IV-24: Powder Depth vs. Rat-Hole Diameter Graph

- Time Consolidated Flow Function Test data shows two sets of Arching and Rat-hole dimensions, one based on the instantaneous flow function curve, and one based on the applicable time consolidated flow function curves. There is an option to use a separate density file.

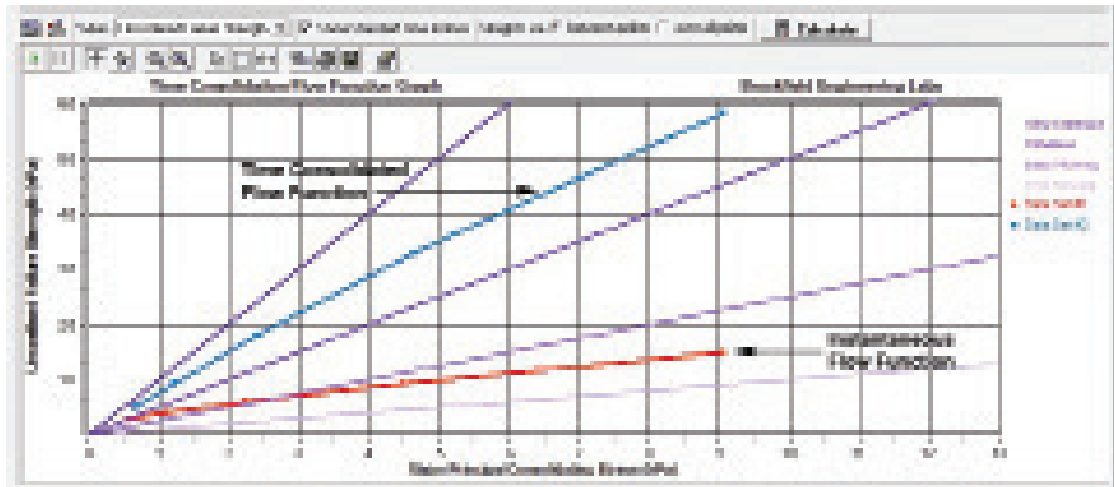

Figure IV-25: Time Consolidated Flow Function Test Graph

- Wall Friction Test data allows the user to calculate several Hopper half angles, one for each Displacement setpoint. The user selects the Flow Function test file in order to perform this calculation. Arching and Rat-hole dimensions are not applicable.
- Density Test data: Not applicable.

IV.7.3 How to Create a Data Report

Once a test has been completed, the user can view an analysis report by pressing the “view report” button shown in Figure IV-26 in the analysis tab. The user can customize the report by checking the boxes below as needed. A report of the corresponding data will be created in tabular format.

Reports can also be created for comparisons and statistics using the same procedure.

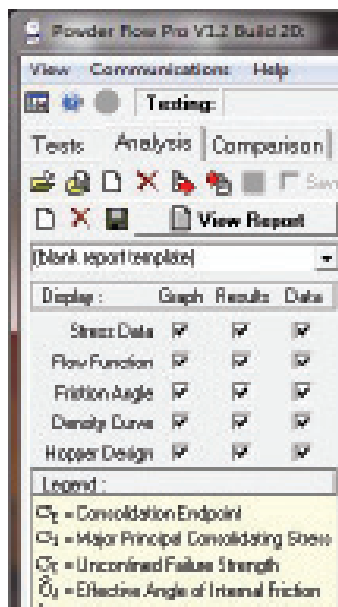

Figure IV-26: View Report Screen

IV.7.4 How to Compare Data

Data sets can be compared using the comparison tab. A user can open up to eight data sets for comparison by double-clicking on the open slots and selecting a data set from the database. Graphs as well as tabular data can be created to show the comparison of like output parameters. For example, if the user wants to compare the flow function graph of many data sets, only flow function test sets can be selected.

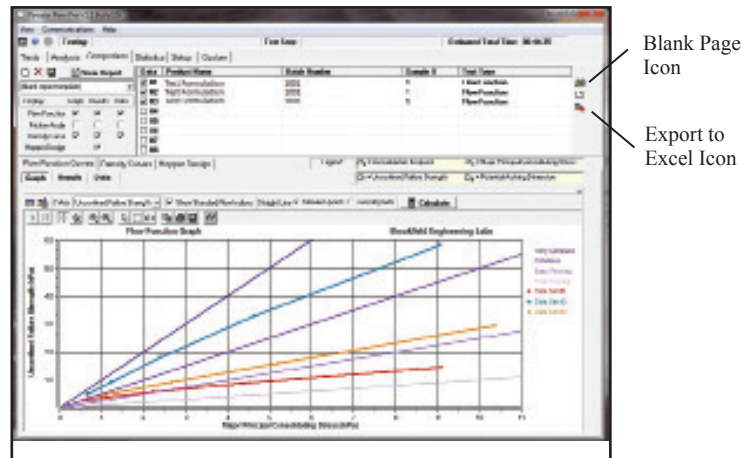

Figure IV-27: Comparison Graph for Data Sets

To clear data sets from the list, highlight over the chosen data set and hit the “Blank Page icon” to erase it from the list. The user also has the ability to export the comparison report to Microsoft Excel™ by using the bottom button with the “arrow icon”.

Comparisons between data files are done using one condition from each file. There are several output parameters to consider. For example, only the Time consolidated values from a Time Consolidated Flow Function test are compared to other files. The instantaneous values for the Time Consolidated Flow Function test are not used in the comparison.

a) Flow Function Curves:

- For Flow Function Test data, the regular Flow Function curve is used for comparisons. This reports the gradient, intercept, critical stresses, and Flow Index based on this Flow Function.
- For Time Consolidated Flow Function Test data, the time consolidated flow curve is used for comparisons. This reports the gradient, intercept, critical stresses, and Flow Index based on this Time Consolidated Flow Function. If you want to compare the instantaneous and time curves within a single Time Test data set, you can do so in the Analysis section.
- Wall Test data: Not applicable.
- Density data: Not applicable.

b) Friction Angle Curves:

- For Flow Function Test data, the Internal Friction Angle curve is used for comparisons. This reports the Internal Angles at critical stresses based on this curve.
- For Time Consolidated Flow Function Test data, the Time Consolidated Internal

Friction Angle curve is used for comparisons. This reports the Internal Angles at the Time critical stresses based on this curve. If you want to compare the instantaneous and time critical stresses within a single Time Test data set, you can do so in the Analysis section.

- For Wall Friction Test data, the Wall Friction Angle curve from the Maximum Wall Locus is used for comparisons. If you want to compare Wall Friction Angle curves at different displacements within the same data set, you can do so in the Analysis section. If a Wall Test data set is part of the Comparison, no angles are reported for critical stresses, because the critical stresses for the Wall file are unknown.
- Density Test data: Not applicable.

c) Bulk Density Curves:

- For Flow Function Test data, the densities measured at the steady state of each locus line is used for comparisons. This reports densities at critical stresses for arching and rat-holing.
- For Time Consolidated Flow Function Test data, the instantaneous density curve is used for comparisons. This reports densities at critical stresses for arching and rat-holing.
- For Wall Friction Test data, the density data from the different consolidation stresses during the test are used for comparisons. If a Wall Test data set is part of the Comparison, no densities are reported for critical stresses, because the critical stresses for the Wall file are unknown.
- For Bulk Density Test data, the density data from the compactions are used for comparisons. If a Density Test data set is part of the Comparison, no densities are reported for critical stresses, because the critical stresses for the Density file are unknown.

d) Hopper Design:

- For Flow Function Test data, the critical values from the regular flow function, friction angle, and bulk density curves are used for comparisons. There is no external Density file option values are taken from within the Flow Function Test data file.
- For Time Consolidated Flow Function Test data, the critical values from the time consolidated flow curve are used for comparisons. Use the instantaneous friction angle along with the density curves. There is no external Density file option. If you want to compare instantaneous and time consolidated outlet sizes within one Time Test data set, you can do so in the Analysis section.
- Hopper Half Angle is not included in the Comparison section, because each calculation requires specifying two data sets, a Flow Function (or Time Consolidated Flow Function) Test and a Wall Friction Test data set.
- Rat-Hole Diameter and Arching Dimension values are displayed for each data set. To get a true Rat-Hole, the Bin Diameter and Height (Powder Height) value must be input. For Arching Dimension, choose either Conical or Plane for the proper hopper outlet.

IV.8 Statistics Page

Statistics can be done on results which have one value per data file. For example, statistics can be done on the slope and angle of the Steady State Failure Locus of 10 Flow Function Test data sets, because each data set has only one Steady State Locus gradient. Statistics could not be done on the Time Consolidation Flow Function Failure Locus gradient, because there are several Consolidation Failure Loci per data set. Up to 30 data sets can be compared.

The image shows a software dialog box titled "View Report". At the top, there are window control icons and a dropdown menu set to "(blank report template)". The dialog is divided into several sections, each with a title and a list of options:

- Steady State Failure Locus**
 - Slope
 - Angle
 - Cohesion
- Flow Function**
 - Straight line:
 - between points
 - over all points
 - Slope
 - Intercept
 - Flow Index at kPa
- Arching**
 - Conical Plane
 - Flow Factor:
 - Arching Dimension
 - Critical Stress
 - Critical Internal Angle
 - Critical Density
- Rat-hole**
 - Flow Factor:
 - Rathole Diameter
 - Critical Stress
 - Critical Internal Angle
 - Critical Density
- Density**
 - Fill Bulk Density
 - Maximum Bulk Density

Figure IV-28: Results Available for Statistical Analysis

The statistics tab can be used to compare different values among many data sets. Reports can be created comparing statistics on “Steady State Failure Locus”, “Flow Function”, “Arching”, “Rat-Hole”, and “Density”.

Refer to Figure IV-29 for an example of several Flow Functions Tests on Limestone Sand.

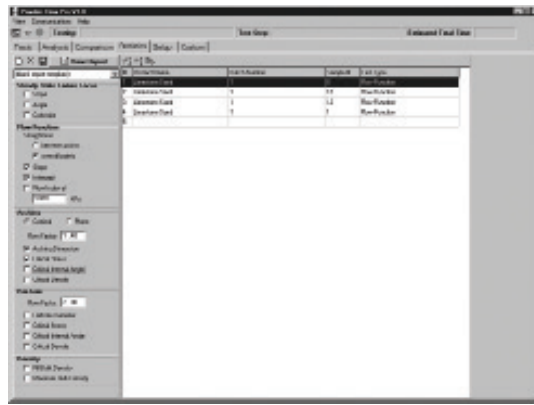

Figure IV-29: List of Limestone Sand Flow Function Data and Results for Statistical Analysis

See Figure IV-30 for an example of the Statistical Report for the Limestone Sand.

Printout from File 418 Brookfield Engineering Labs, Inc.

STATISTICAL REPORT

TEST INFORMATION				RESULTS			
TEST NUMBER	TEST NAME	STRESS (lb)	TEST TYPE	Flow Function Slope	Flow Function Intercept	Arching Dimension	Critical Arching Stress
1	Steady State Locus	1	Flow Function	0.000	14.000	0.000	0.000
2	Steady State Locus	1	Flow Function	0.000	0.000	0.000	0.000
3	Limestone Sand	1	Flow Function	0.000	0.000	0.000	0.000
4	Limestone Sand	1	Flow Function	0.000	0.000	0.000	0.000
STATISTICAL SUMMARY:			Minimum	0.000	0.000	0.000	0.000
Flow Function Slope (lb/lb)			Maximum	0.000	0.000	0.000	0.000
Flow Function Intercept (lb)			Average	0.000	0.000	0.000	0.000
Arching Test Number (lb)			Minimum (lb)	0.000	0.000	0.000	0.000

Figure IV-30: Example of Printout for a Statistical Report

The following statistical reports can be created for the types of test data as indicated:

- **Statistics for Flow Function and/or Time Test data sets:**
 Statistics can be done on the following results: Steady State Locus gradient, angle, and cohesion; Flow Function gradient, intercept, and Flow Index at a given stress; Arching dimension and critical arching stress, friction angle, and density; Rat-hole diameter and critical rat-hole stress, friction angle, and density; fill bulk density and maximum bulk density.
- **Wall Friction Test data sets:**
 Statistics can be done on the Maximum Wall locus gradient, angle, cohesion and angle at a given stress, fill bulk density and maximum bulk density.
- **Bulk Density Test data sets:**
 Statistics can be done the fill bulk density and the maximum bulk density.

IV.9 Setup Page

The setup page allows the user to change the measurement units and select from a list of Advanced Options. Advanced Options allow the user to display a Custom Tests option under the Test tab. For a Custom Test method, set Pass/Fail limits on the Flow Function graph, display a Flow Index for a defined Major Principle Consolidation Stress under a Flow test, adjust the Arching Flow Factor for the Hopper Design, and choose a Separate Density File (rather than a Wall Friction file) for a Hopper Half Angle calculation.



Figure IV-31: Advanced Options

The Data File Management icon allows the user to import and export data stress files, export to Excel and backup and archive data.

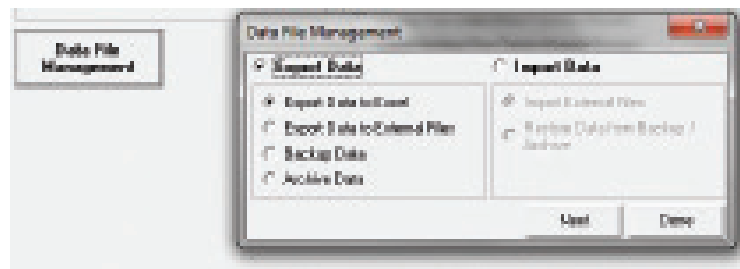

Figure IV-32: Data File Management

Data can be exported or imported by clicking the appropriate icons at the top of the Analysis tab ('arrow leaving page' icon for export and 'arrow entering page' for import).

Data files can be exported to either an Excel format or in an External Stress Data file format, called ".ADTG", which utilizes the Access Database.

The ".ADTG" file format can be used to transfer data files from one computer to another, both computers must run Powder Flow Pro software:

- 1) Export the data file as an External file (*.ADTG).
- 2) Move the resulting External file to the other computer.
- 3) Import the file using that computer's Powder Flow Pro software.

IV.10 Custom Page

The custom tab can be used to look at control windows by making the user's own customized display. Control windows can be moved into the custom page by either right clicking or selecting the desired windows from the pop-up list or by undocking the control window, which can be done by double-clicking the bar on the top or left of the window, and dragging it to the Custom Page. See Figure IV-33.

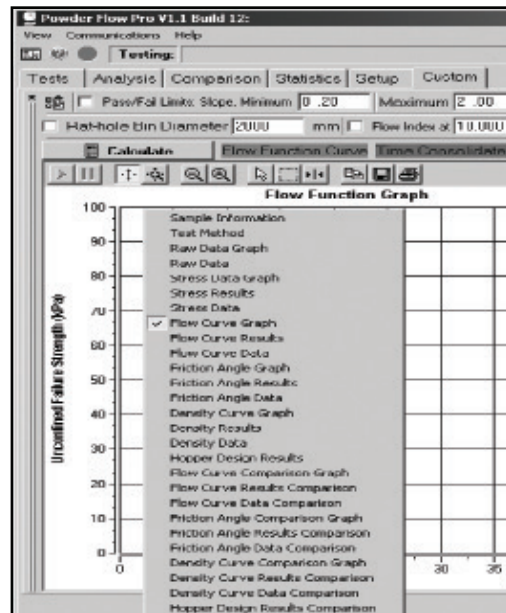

Figure IV-33: Custom Page

IV.11 Help Files

Help files are located in the Powder Flow Pro Software in the top left corner signified by a "question mark icon". These files will help the user get a better understanding on how the PFT works. The help section also helps guide the user in setting up and running an accurate test.

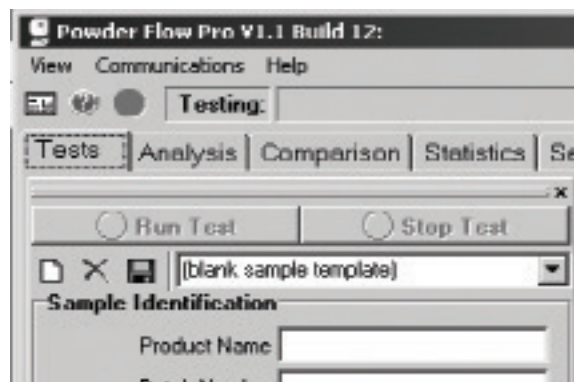

Figure IV-34: Help Icon

Appendix A: Overview of Powder Flow Properties

Problems with Powder that relate to Gravity Flow Behavior

A typical industrial powder processing line will include several storage vessels (e.g. bins, bunkers, silos, hoppers, Intermediate Bulk Containers (IBCs), sacks etc), feeding or handling steps (e.g. belt conveyor, screw conveyor, pneumatic conveyor, gravity chutes etc) and processing steps (e.g. milling, mixing, drying, bagging etc). A major industrial problem is getting the powder to discharge reliably from storage into the next process step. Therefore to understand the application of powder flow measurements, it is useful to have some background knowledge of the flow patterns and flow obstructions that can occur inside the storage vessels on a processing line.

What are the powder flow patterns that can occur in a process storage vessel?

Principally there are two different flow patterns that can occur:

Core-flow (shown in Figure A-1a) can be considered the default flow pattern and is characterized by powder discharge through a preferential flow channel above the draw down point of the outlet. Powder is drawn into the flow channel from the top free surface of the inventory. This gives a first-in last-out discharge regime and, if operated on a continuous (rather than batch) mode, the powder around walls in the lower section will remain static in the vessel until the time that it is drained down to empty.

Mass-flow (shown in Figure A-1b) is the desirable flow pattern for powders that are poor flowing or time sensitive, but must be specifically designed for. Here the entire contents of the vessel are 'live', giving a first-in first-out discharge regime. To achieve this, the hopper walls must be sufficiently steep and smooth. For a given wall material/converging angle, the powder wall friction must be below a critical value. Also, the product discharge must be controlled by a valve or feeder that allows powder to flow through the entire cross sectional area of the outlet. (It is this final point that prevents many vessels from operating in mass-flow.)

A wall friction test will be able to give an approximate assessment of whether a given hopper geometry will support mass-flow (with the proviso that the outlet area is fully active). For an exact calculation of the maximum mass-flow hopper half angle, both wall friction and flow function tests must be undertaken.

What are the powder obstructions that can occur to prevent flow?

Principally there are two different flow obstructions that can occur:

'Rat-holing' (shown in Figure A-2a) is the principle flow obstruction in a core-flow vessel, where the powder in the flow-channel above the outlet discharges leaving a stable internal structure.

'Arching' (shown in Figure A-2b) is the flow obstruction in a mass-flow vessel, where a stable powder arch forms across the outlet or converging walls of the hopper, thereby preventing flow.

For a given powder there is a critical outlet dimension that must be exceeded to ensure reliable discharge of a core-flow or mass-flow vessel. These are the critical rat-hole diameter D_{RH} and the critical arching diameter D_c or D_p (depending on the hopper geometry). The Brookfield Powder Flow Tester (PFT) can calculate these critical dimensions following a flow function

measurement. An accurate dimension requires a wall friction test as well. Note that for a given powder, the rat-hole diameter is significantly larger than the arching diameter.

What are the flow patterns that can occur?

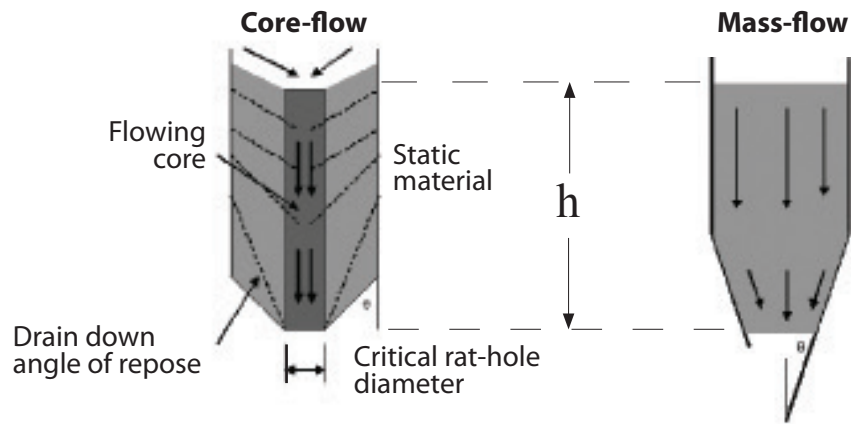

Figure A-1a: Core-flow

Figure A-1b: Mass-flow

What are the forms of the flow obstructions?

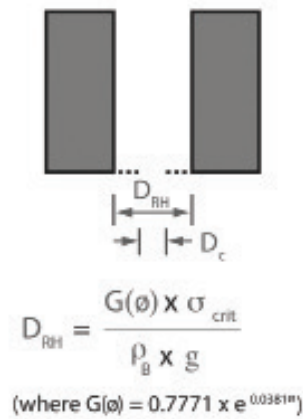
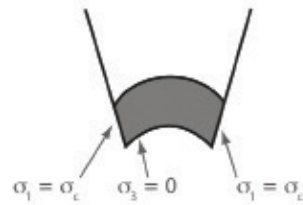

Figure A-2a: 'Rat-hole'



Conical Hopper: $D_c = \frac{2 \times \sigma_c \times 1000}{\rho_b \times g}$

Plane Hopper: $D_p = \frac{\sigma_c \times 1000}{\rho_b \times g}$

(where $3dp < L$)

Figure A-2b: Arch

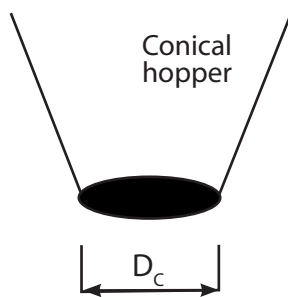

Figure A-3a: Conical hopper

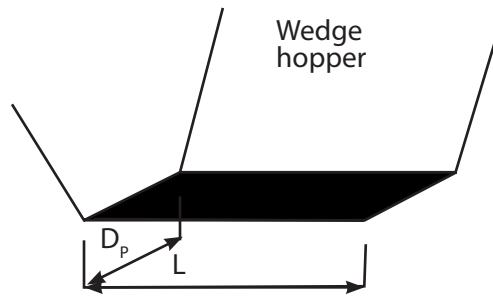

Figure A-3b: Wedge (plane) hopper

Note: Two types of hopper shape are considered: conical hoppers and wedge (or plane) hoppers as shown in Figure A-3a & A-3b.

Key differences between powders and fluids

For any fluid the resistance to shear (viscosity) is independent of the normal pressure but dependent on the shear rate. In powders the effect of these factors is reversed so that shear stress of a powder is strongly dependent on the normal stress but independent of the shear rate. Hence when characterizing powders, test are undertaken at a single speed but over a range of normal stresses. The other key difference is that powders are anisotropic so the stresses are not equal in all directions and are frictional so that they can generate shear stresses at wall boundaries (see wall friction section).

Flow function test

The primary measure of powder flowability is the powder flow function – which gives a measure of the amount of strength the material retains at a stress free surface following consolidation to a given stress level. The simplest way of explaining the flow function is with the uniaxial unconfined failure test shown in Figure A-4, which measures the strength of a free standing column of powder. This condition is analogous to the condition of the powder arch across a hopper outlet shown in Figure A-2b.

- i) **Consolidation of sample.** Powder is placed in a cylindrical cell and compacted under a known normal stress σ_1 .
- ii) **Unconfined sample.** The mold is now carefully removed to reveal a compacted column of powder.
- iii) **Unconfined failure of sample.** The normal stress acting on the column of powder is gradually increased until failure occurs, and the peak normal stress σ_c is recorded.

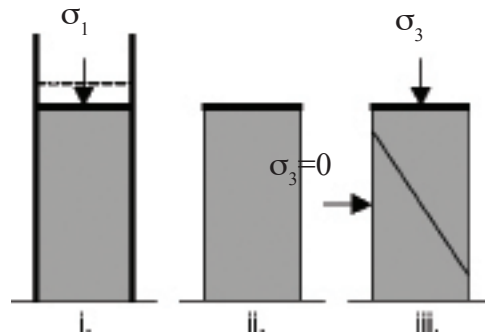

Figure A-4: Uniaxial unconfined failure test

The above uniaxial unconfined failure test is conducted over a range of consolidation stresses and the flow function is constructed by plotting the unconfined failure strength versus the consolidation stress as shown in Figure A-5.

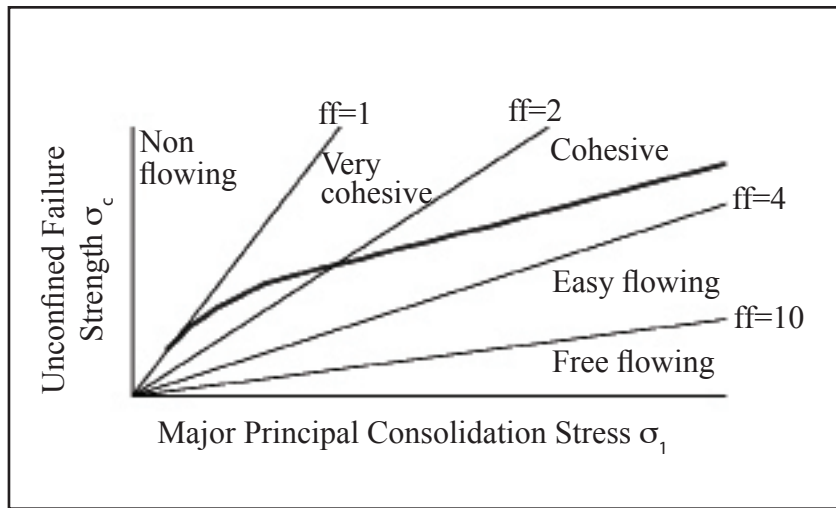

Figure A-5: *The powder flow function*

The standard classification of powder flowability uses the flow factor index ff , as shown above:

$ff < 1$	Non flowing
$1 < ff < 2$	Very cohesive
$2 < ff < 4$	Cohesive
$4 < ff < 10$	Easy flowing
$10 < ff$	Free flowing

Anticipated uses of the Brookfield Powder Flow Tester:

Benchmarking - Measure flow properties on all raw powders and blends to determine if there are differences in their flowability and whether these correspond with plant experience.

New materials - Test new ingredients/blends versus existing ingredients/blends to determine whether the alternative material is likely to be easier, more difficult or no different to handle. This potential material handling cost can be factored into the purchasing decision.

Reverse engineering - If you have plant experience with powders that flow easily or poorly on a given process line, you can use the PFT to determine the flow properties of each powder and determine over time a flowability window required for flow on a given line.

Design - Design the geometry (converging angle and outlet size) of new hoppers/silos for reliable flow.

Alternative methods of displaying the flow function test results

To demonstrate powder flowability, the flow function can be presented graphically (as in Figure A-5) to describe behavior over the stress range of approximately 0.6kPa to 10kPa. This stress range is representative of that experienced by the powder in small to intermediate sized silos. However, describing flowability with a function may complicate the analysis as it is sometimes found that the flow functions of two different materials cross over one another, so that their relative ranking changes with stress levels. Alternatively, flowability rankings for specific stress levels can be determined by calculating the following parameters:

- **Estimated Critical Arching diameter [m]:** The minimum silo outlet size for reliable gravity discharge in mass-flow, calculated using the arching equation in Figure A-2b. The stress value is the intercept of the flow function with an $ff=1.4$ line*.
 - **Estimated Critical ‘Rat-hole’ diameter in [m]:** The minimum outlet diameter to prevent the formation of a stable ‘rat-hole’ in a core-flow vessel. The outlet diameter is calculated using the rat-holing equation in Figure A-2a. Refer to the help files on Rat-hole diameter in the Power Flow Pro software.
 - **Flow index:** The gradient of a line from the origin to the last point on the flow function (by default**), typically in the range of 0.1 to 1.0. This index will give a comparison of materials behavior at intermediate compaction stresses greater than one meter depth of powder.
 - **Flow intercept:** The intercept of the best fit linear flow function with the unconfined failure strength axis giving a number in kPa. This gives a number that reflects the powders flowability at compaction stresses typically less than 0.15m depth of powder.
- * These are the default flow factor settings but they can be adjusted by the user within a 1.0 to 10.0 range for silo design applications.
- ** Can be user set to any stress level.

Time consolidation test

The Time Consolidated Flow Function test compares the cohesive strength or hopper flow behavior of a powder that has experienced a brief interruption of flow (a few seconds), to the same powder after it has experienced static storage in the hopper for an extended period of time (ex. overnight or over the weekend).

Note that the Friction Angles and Density Curve for a Time Consolidation test are based solely on the instantaneous flow data and are therefore exactly the same as described in the Flow Function section.

Note: A time consolidated flow function test allows the user to investigate whether the material gains strength during long term storage.

Wall friction test

The friction acting at the wall/powder interface has a significant influence on the stress distribution within processing vessels, silos and hoppers.

As wall friction increases, more of the powder weight is transferred down through the silo/vessel/container walls, rather than compacting the bulk solid below. The lower the friction, the more the self-weight is transmitted through the bulk solid. This ‘Janssen effect’ is illustrated in Figure A-6, which demonstrates how the vertical pressures in the vertical section of a silo would vary if the wall friction were increased from zero to a large value of 40° . The presence of the wall friction has a negative feedback effect on the pressure increase with depth, so generally the stresses approach constant values at a depth of approximately 4 vessel diameters.

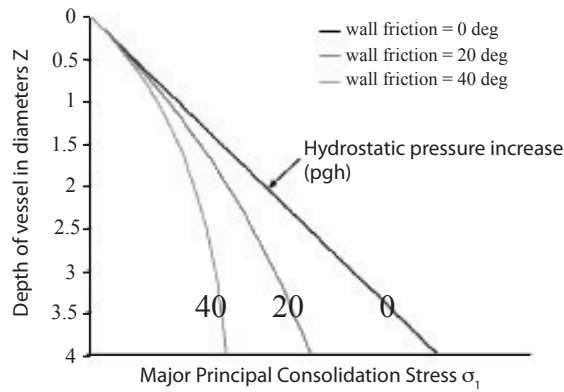

Figure A-6: Stress distributions in vertical walled vessels

Software can be used to estimate pressures in a container based on measurements of the bulk density ρ , wall friction ϕ_w , internal friction δ , and container diameter D . The principal consolidation pressure σ_1 at depth Z is given by the following equation. This equation is used for Rat-hole calculation.

$$\sigma_1 = \frac{\rho \cdot g \cdot D}{4 \cdot \lambda \cdot \tan \phi_w} \cdot \left(1 - e^{-\frac{4 \cdot \lambda \cdot \tan \phi_w \cdot Z}{D}} \right)$$

We assume: $\lambda = 0.4$

This applies only to the vertical section of the bin or silo. “Kick-pressure” has an effect when the powder gets into the hopper section.

The wall friction angle represents the angle to which a wall surface must be inclined as shown in Figure A-7 to cause powder to slip. The wall friction angle is typically in the range of 10 to 45 degrees.

The wall friction angle is also called the chute angle.

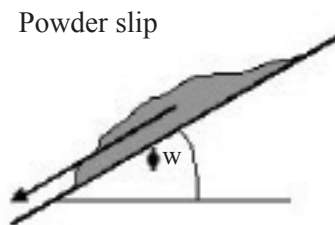

Figure A-7: Wall friction

Outputs of the wall friction test

While the results of the wall friction test can be displayed graphically in the form of a wall friction locus as shown in Figure A-8a (representing the limiting shear stress the powder can support at a wall), or the form of a wall friction angle function as shown in Figure A-8b (representing how the wall friction angle changes with reducing stress), one of the following four flow indices derived from the maximum wall friction locus are usually adequate. These wall friction properties are:

- θ_c, θ_p The maximum mass-flow hopper half angle (measured to the vertical) for conical or planar hoppers.
- φ_w The maximum wall friction angle to determine the minimum chute angle for gravity flow (see Figure A-8b).
- **Grad** The maximum wall friction angle displayed as a coefficient.
- c_w The wall cohesion shear stress in kPa that can be supported at the wall under zero normal stress (see Figure A-8a). This determines the ‘stickiness’, i.e. whether powder is likely to stick to wall surface under close to zero stress. i.e. will powder build up on the walls of the chutes around discharge/transfer points.

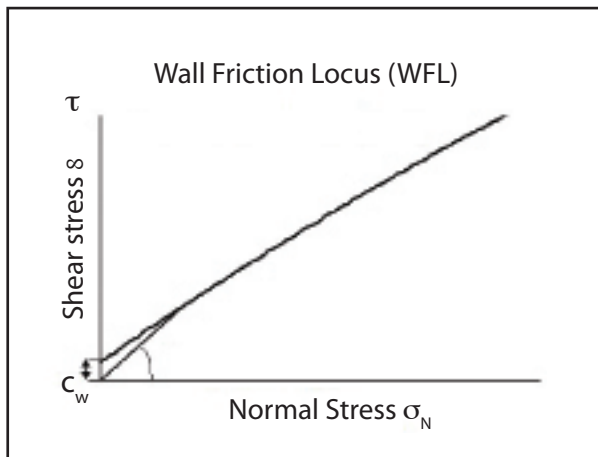

Figure A-8a: Wall friction locus

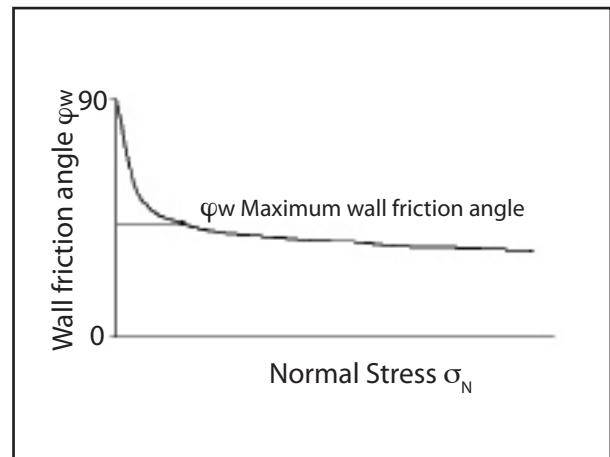

Figure A-8b: Wall friction function

An extended wall friction test allows the wall sample to be subject to large shear displacements (on the order of 30 meters) to establish whether long term powder build up on the wall would be expected.

Bulk density test

It is the self-weight of the powder, its bulk density, that controls the stresses acting on the powder when flowing or when static in processing lines/ silos etc. The bulk density is measured during the course of the flow function test (and is required to calculate the critical outlet dimensions) and the wall friction test, but it can also be measured in a separate single test for bulk density alone.

Compacted bulk
density (ρ_{comp})

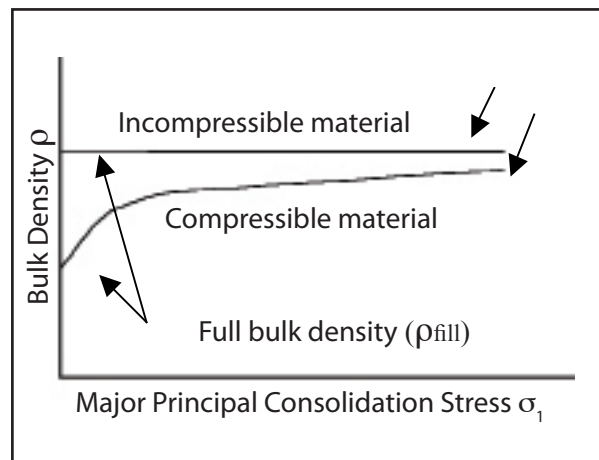

Figure A-9: Bulk density curve

The bulk density is commonly displayed as a bulk density curve (Figure A-9). Generally a free flowing material will be incompressible and only show a small increase in density with stress. A very cohesive, poorly flowing, bulk solid by comparison will show a large increase in bulk density with increasing stress.

ρ_{fill} The fill bulk density, when the powder is just poured into a container

ρ_{comp} The bulk density after the material is poured and compacted to high stress.

Summary

To summarize, the Brookfield Powder Flow Tester offers four standard tests,

1. **Flow function test** - Measures internal strength, flow function, internal friction angle and bulk density - used for characterizing the flow strength and arching/ rat-holing potential of powders.
2. **Time consolidated flow function test** – Same as above but following static storage for a user defined time period.
3. **Wall friction test** - Measures friction between the powder and a given wall surface and the bulk density – used for assessing mass-flow hopper half angles and gravity flow chute angles.
4. **Bulk density test** – Measures bulk density curve of the powder.

Note: To undertake a full silo design requires the user to run and combine the results of tests 1, 2 and 3.

Appendix B: Glossary

Angle of Wall Friction:	Represents the friction between the sliding powder and the wall of the hopper or chute at the onset of flow.
Arching Dimension:	Minimum hopper outlet size needed to insure that the powder will discharge in Mass Flow instead of forming a stable arch across the opening.
Axial Distance:	Distance between the lid and the bottom of the trough, indicating the depth of the powder.
Bin Diameter:	Maximum internal diameter of the storage vessel. For square or rectangle vessels, the equivalent bin diameter should be used.
Bulk Density:	The mass of the powder divided by its total volume.
Cohesion:	A measure of the strength retained by a powder after it has been compacted to a given Consolidation Level.
Consolidation:	The process of applying a Normal and a Shear stress to a bulk solid to move the particles together, in order to observe any increases in its Cohesion, Bulk Density, etc.
Core-Flow:	A first-in last-out discharge pattern where the powder flows from the top of the vessel through a vertical channel above the outlet. Powder that is near the walls of the vessel remains stagnant until the level descends to the point where that powder is at the top surface.
Critical Arch:	The largest arch span that a given powder can support before collapsing under its self weight.
Critical Consolidation Stress:	
For Arching:	The Major Principal Consolidating Stress acting on the powder in the hopper at critical arching dimension during mass flow.
For Rat-Hole:	The Major Principal Consolidating Stress acting on the powder in the region of the outlet due to the head of powder in a core flow hopper.
Critical Density:	The Bulk Density of the powder forming the Critical Arch or the Critical Rathole. This is determined by taking the Bulk Density at the corresponding Critical Consolidation Stress.
Critical Internal Friction Angle:	The Internal Friction Angle of the powder forming the Critical Arch or the Critical Rathole. This is determined by taking the Internal Friction Angle at the corresponding Critical Consolidation Stress.
Critical Rathole:	The largest Rathole diameter a powder can support before collapsing in a Core Flow regime.
Critical Stress:	The Unconfined Failure Strength of the powder forming the Critical Arch or the Critical Rathole. This is determined by taking the Unconfined Failure Angle at the corresponding Critical Consolidation Stress.

Critical Wall Friction Angle:

The Wall Friction Angle of the powder forming the Critical Arch or the Critical Rathole. This is determined by taking the Wall Friction Angle at the corresponding Critical Consolidation Stress.

Effective Angle of Internal Friction:

Represents the friction between sliding layers of powder, defines the ratio of the major and minor principal consolidation stresses during steady state flow.

Failure Locus:

The line of maximum Shear Stress that a powder can support before flow occurs under various Overconsolidated Normal Stresses. This is dependant on the Consolidation Level.

Fill Density:

The Bulk Density of the powder in the trough before any stress is applied.

Flow Factor:

(Arching) Ratio of the consolidation stress in a powder during Steady State Flow to the stress required to set up a stable arch. This factor depends on both the flow properties of the powder and the shape of the hopper.

Flow Function:

Line of a powder's Unconfined Failure Strength versus the Consolidation stress that is applied to it.

Free-Flow:

The powder flows reliably through very small outlet dimensions under gravity. Arching and Ratholing does not occur. This is indicated in hopper calculations as "Free Flow" or "0.0".

Geometric Spacing:

Series of values where each value is equal to the previous value times a constant factor. The factor is chosen to space the values over the entire range. In this type of series, there will be more values at the lower end of the range.

Hopper Half Angle:

Maximum angle of the converging hopper wall (from the vertical axis) needed to ensure Mass Flow. Angles greater (shallower) than this will produce Core Flow.

Major Principal Consolidation Stress:

The largest stress acting on the powder during Steady State Flow.

Mass-Flow:

A first in-first out discharge pattern where the powder flows at the vessel walls and all the material is in motion.

No Flow:

(Arching) For the given Flow Factor, the powder always arches. This is indicated in the hopper calculations as "No Flow" or "-----".

Normalized Flow Function:

A version of the Flow Function graph. The "normalized" flow function provides a means for comparing powder. The graph plots "potential arching diameter" against "major principal consolidation stress". The mathematics involves dividing the density of the powder at each consolidation stress into the value for the unconfined failure strength. This approach analyzes the strength of the powder in the abstract, which means that the influence of the hopper is not included.

Normal Stress:	The stress due to the Axial Load. It is stress applied perpendicular (normal) to the powder bed.
Overconsolidation:	After Consolidation, reducing the Normal Stress without shearing so that the Bulk Density is high relative to the new Normal Stress.
Rathole Diameter:	Minimum outlet diameter of a Core Flow hopper needed to ensure that the powder will flow instead of forming a stable Rathole.
Shear Stress:	The stress due to the Torsional Load. It is the stress between parallel layers of powder (Flow Function and Time Consolidated Flow Function tests) or between a layer of powder and the lid (Wall Friction test).
Steady State Flow:	Continuous powder flow where the Normal and Shear Stresses have reached a constant level.
Time Consolidated Test:	Compacts the powder at a given Consolidated Level for an extended period of time (hours, overnight to represent static storage in a hopper).
Torsional Distance:	Distance that the trough has rotated from its starting position at the beginning of the test.
Unconfined Failure Strength:	The stress required to cause a powder to flow at a stress free surface, after it has been compacted to a given Consolidation Level.
Wall Cohesion:	A measure of the potential for the powder to stick to a wall surface. This depends on the Consolidation Level.
Wall Friction Test:	The distance the powder travels across the wall surface before the Failure Locus is measured.

Appendix C: PFT Packing to Ship for Repair and Service

Note: All items must be packed as shown. If your packaging is missing, please contact Brookfield Engineering for replacement parts. Failure to do so could result in costly damage to the PFT.

If you saved the original packing instructions which came with the PFT, use them in accordance with the following instructions on page 63.

If you have ordered new packaging materials from Brookfield or an authorized dealer (Part Number: PFT-REPACK), the following items have been provided in the Repack Kit:

PFT RSC 500DW (accessory box) (qty 1):	PFT-PACK1
PFT HSC 500DW (large outer box) (qty 1):	PFT-PACK2
PFT Tray Stitched (qty 1):	PFT-PACK3
1.7# PE Foam D/C's (bottom) (qty 1):	PFT-PACK4
1.7# PE Foam D/C's (top) (qty 1):	PFT-PACK5
PFT Shipping Pallet (qty 1):	PFT-PALLET
Poly Bag for PFT Shipping Pack (qty 1):	PFT-BAG
Shipping Foam, Compression Plate (qty 1):	PFT-104
Shipping Foam (6-inch Trough) (qty 1):	PFT-101
Shipping Foam (5-inch Trough) (qty 1):	PFT-106
3x3x3 .225 Strapping Protectors (qty 8):	CTN-14
Label, Box, Packaging & Shipping Info (qty 2):	LBL11-PFT3
Set of 2, 1in. x 12ft. Lashing Straps (qty 2):	PFT-116
PFT Packing Instructions for Shipping (qty 1):	T11-1041
Velcro Strapping, 5/8 wide (qty 1):	PFT-115

Bubble bags, rubber bands and packing newspaper will also be supplied in the Repack Kit.

Detailed instructions for packaging the PFT proceed on the following page. It is important to follow these instructions completely in order to prevent damage to the PFT during shipment.

- 1) Screw feet in all the way.



- 2) Ensure that the Vane Lid (Part Number PFT-500 for 6" Lid or Part Number PFT-515 for 5" Lid) and Trough (Part Number PFT-400 for 6" Trough or Part Number PFT-405 for 5" Trough) are installed on the PFT. This is necessary in order to lock the suspension system inside the instrument so that movement cannot take place during transport.

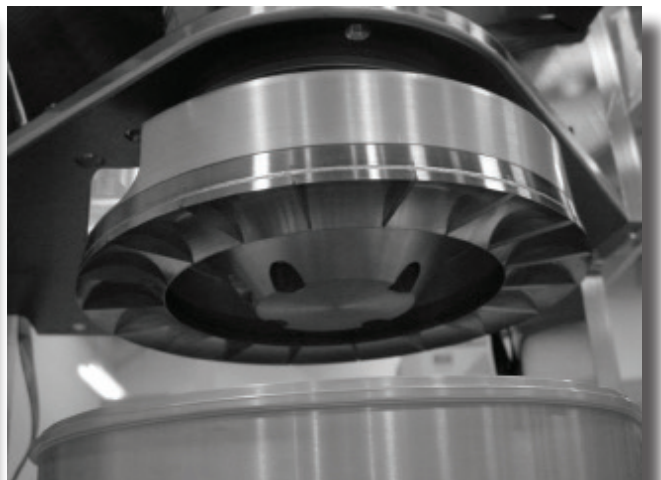
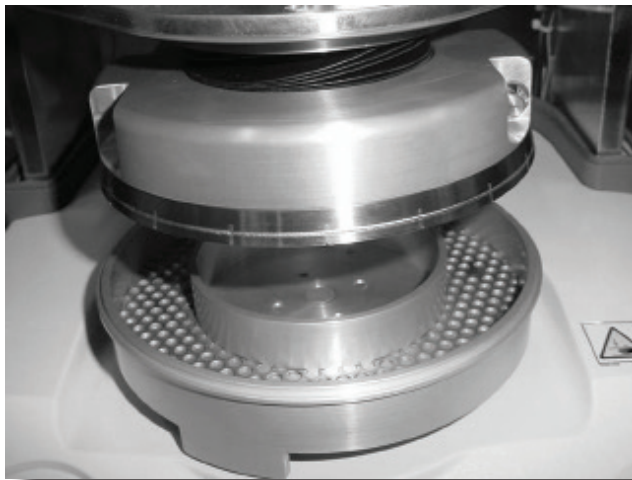

- 3) Raise the Vane Lid to its uppermost position by pressing the up arrow.

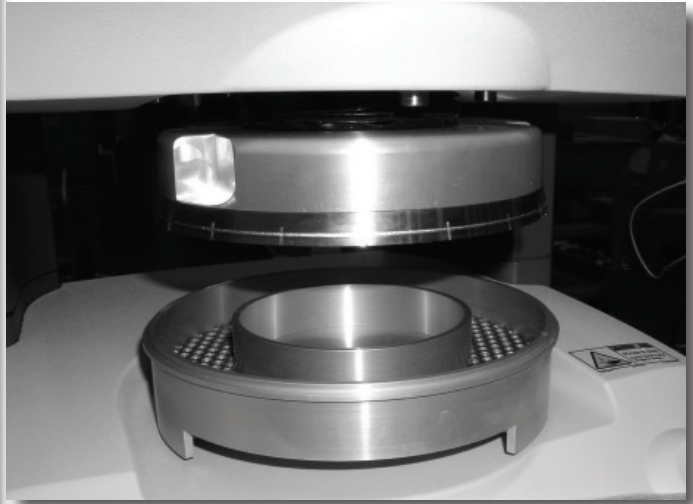

- 4) Place the circular foam insert (PFT-101 for 6” Trough and PFT-106 for 5” Trough) into the Trough. Remove the Trough to accomplish this, if necessary, from the PFT. Install the Trough on the PFT.

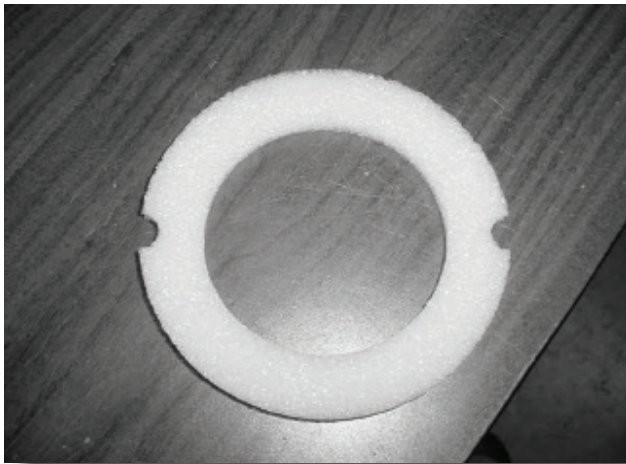

- 5) Press the down arrow to lower the Vane Lid until it just makes contact with the foam insert. Then press and hold the down arrow for 2 seconds. This will adjust the position of the Vane Lid so that the foam is slightly compressed. Do not hold longer than 2 seconds because this will cause further compression of the foam insert, which is not desired.

- 6) Insert the horseshoe shape foam collar (PFT-104) over the Lid and Trough.

NOTE: Flex the collar to an open position when installing around the bellows to ensure that the bellows do not deform.

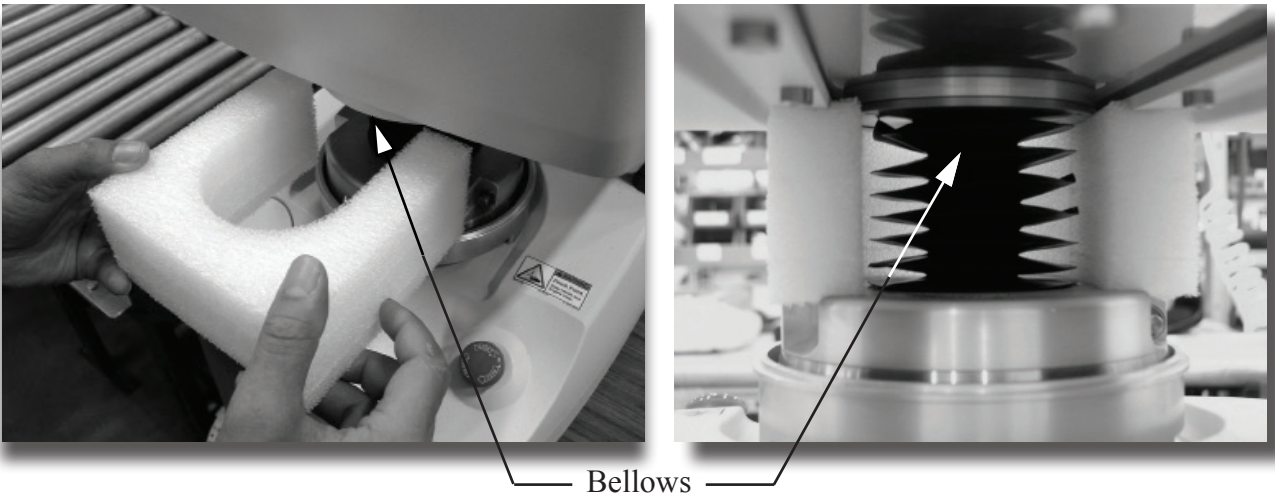

- 7) Secure the access door for the bubble level by using plastic shrink wrap or tape that will not damage the paint. Secure the foam collar with plastic shrinkwrap or Velcro Strapping (Part Number PFT-115), which is also supplied in the Repack Kit.

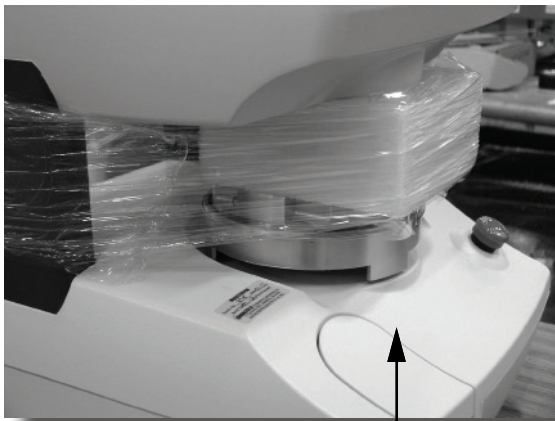

Access Door for Bubble Level

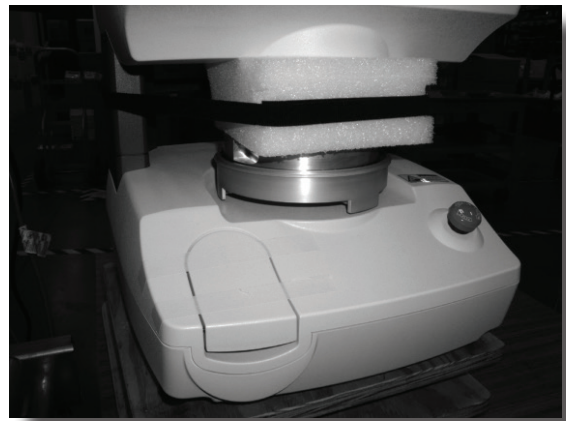

- 8) Insert the bottom foam packaging piece (PFT-PACK4) into the bottom of the outer carton packaging kit (PFT-PACK3) and place onto the pallet (PFT-PALLET), which is also supplied in the Repack Kit.

NOTE: The marks indicating the front have two cut outs.

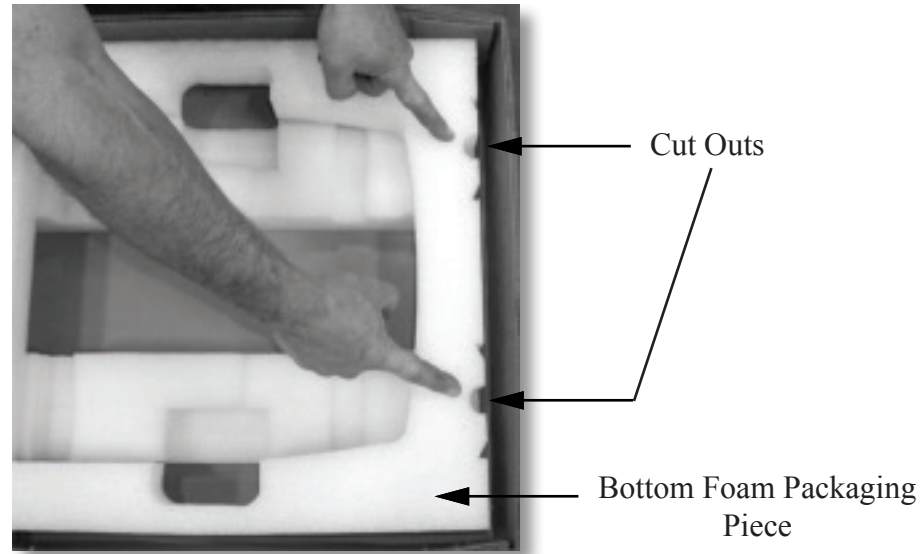

- 9) Place the plastic bag (PFT-BAG) onto the bottom foam packaging piece and open the bag.
- 10) Gently insert the PFT into the bottom foam piece. Locate and lift the instrument, using the hand-hold positions on the bottom and back of the PFT. This requires two people to lift the instrument.

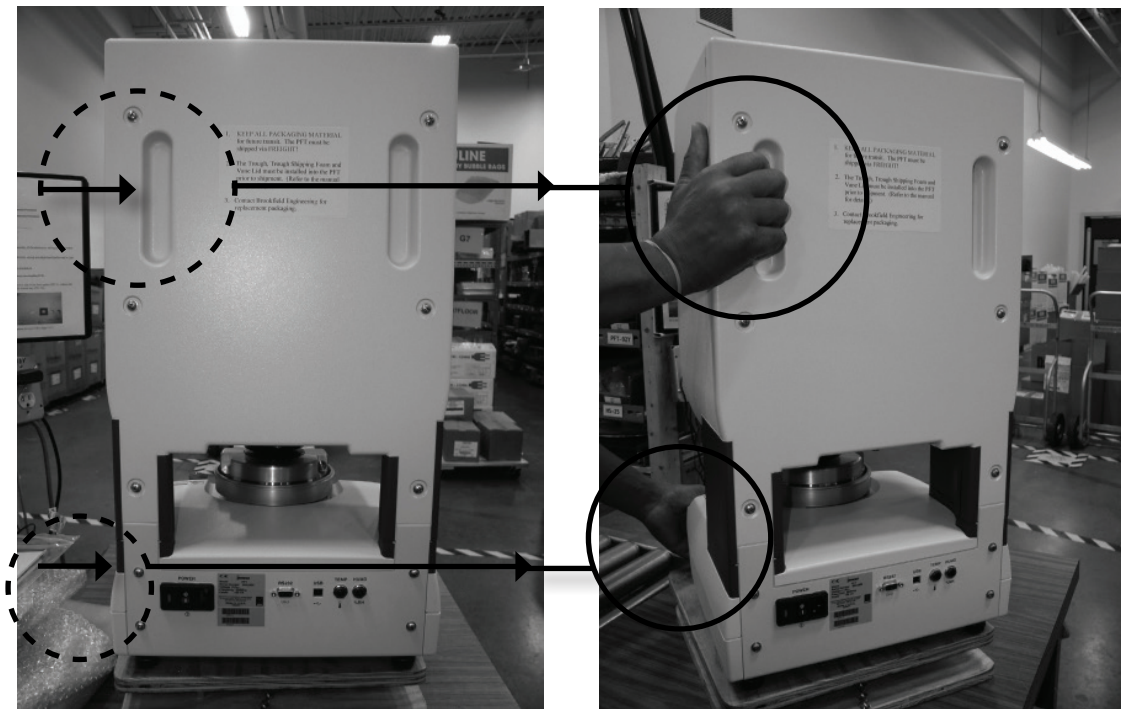

- 11) Slide the plastic bag up over the PFT from the bottom to the top.
- 12) Secure the plastic bag at the top with a rubber band, which is supplied in the Repack Kit.



- 13) Place the top foam packaging piece (PFT-PACK5) on top of the PFT.



- 14) Slide the outer carton box (PFT-PACK2) over the PFT and insert between the outer carton packaging kit and the bottom foam packaging piece.

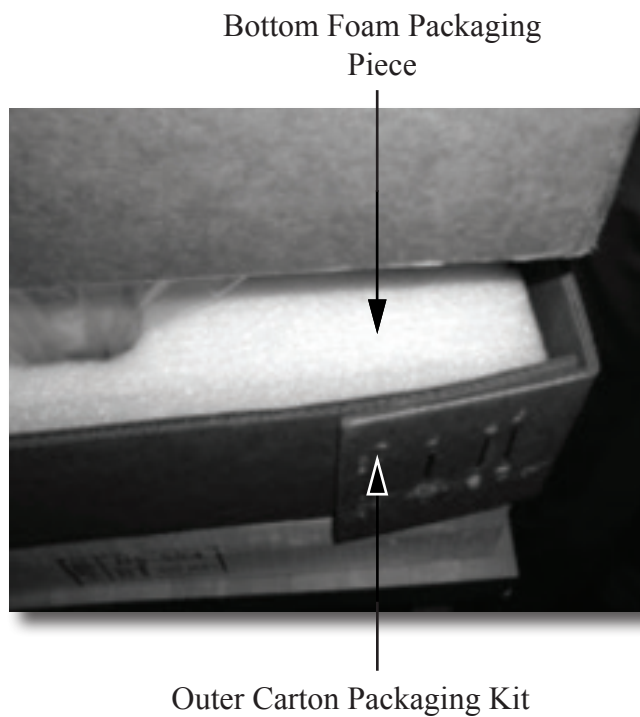

- 15) If the PFT will be sent back to you after repair or calibration, it is not necessary to return the accessory items other than the Vane Lid and Trough, which are already installed on the instrument. If the PFT is not being sent back to you, package all necessary items in bubble bags and place in accessory carton (Part Number PFT-PACK1).



- 16) Close and tape up the accessory carton.



- 17) Place the accessory carton (PFT-PACK1) on top of the top foam packaging piece. If you do not have the accessory carton, please contact Brookfield for replacement parts. If the accessory carton is not used, damage to the instrument may occur.



18) Close, tape and seal the outer carton box top.



19) Use 2 straps with the strapping protectors (Part Number CTN-14) to secure the outer carton packaging kit (Part Number PFT-PACK3) in one direction. Strap the outer carton to the pallet using 2 more straps with strapping protectors (Part Number CTN-14) in the other direction (see Figure A). If you have the Repack Kit, use the lashing straps (Part Number PFT-116) with the strapping protectors (Part Number CTN-14) (see Figure B). Straps **MUST** be secured tight to prevent any damage to the instrument while in transit.

Figure A



Figure B



- 20) Apply labels which say “SHIP ONLY BY FREIGHT”. These labels are included in the Repack Kit (Part Number LBL11-PFT3). Place one label on the top of the shipping carton and one on the side, see figures below.

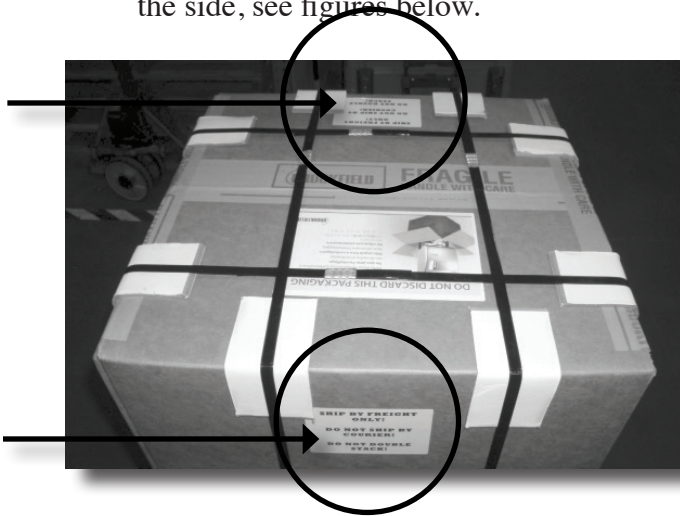

- 21) **SHIP THE CARTON BY FREIGHT!** Do not use a package carrier service. It is important that the carton remain in an upright vertical position during shipment in order to protect the instrument from damage.

Appendix D: Warranty Repair and Service

AMETEK Brookfield Viscometers are guaranteed for one year from the date of purchase against defects in materials and workmanship. They are certified against primary viscosity standards traceable to the National Institute of Standards and Technology (NIST). The Viscometer must be returned to AMETEK Brookfield or to the authorized dealer from whom it was purchased for a warranty evaluation.

Transportation is at the purchaser's expense. The Viscometer should be shipped in its carrying case together with all spindles originally provided with the instrument. If returning to AMETEK Brookfield, please contact us for a return authorization number prior to shipping.

All AMETEK Brookfield DVPlus Viscometers are supplied from the factory with a Calibration Seal (Located on the back of the viscometer). The warranty stated above will be voided if the Calibration Seal has been damaged. Only AMETEK Brookfield or our authorized servicing dealers may break the Calibration Seal for purposes of instrument repair or recalibration.

For a copy of the Repair Return Form, go to the AMETEK Brookfield website:

www.brookfieldengineering.com

For repair or service in the United States, return to:

USA - Headquarters

AMETEK Brookfield
11 Commerce Blvd.
Middleboro, MA 02346 USA
Phone: 1-800-628-8139
Phone: 1-508-946-6200

Email (Sales): ma-mid.sales@ametek.com
Email (Service): ma-mid.ccs@ametek.com

www.brookfieldengineering.com

USA - Chandler, AZ

AMETEK Brookfield
3375 N. Delaware St.
Chandler, AZ 85225 USA
Phone: 1-800-528-7411
Phone: 1-602-470-1414
Fax: 1-602-281-1745

Email (Sales): SalesTeam.azic@ametek.com
Email (Service): CSS.azic@ametek.com

www.brookfieldengineering.com

For repair or service outside the United States, consult AMETEK Brookfield or the local authorized dealer from whom you purchased the instrument.

For repair or service in China, return to:

AMETEK Commercial Enterprise (Shanghai) Co. Ltd.
Room 810 Dongbao Plaza, No.767 East
Dongfeng Road, Guangzhou, China (510600)
Tel: 86-20-8363 4768
Fax: 86-20-8363 3701
Email (Sales): brookfield-china.sales@ametek.com
Email (Service): brookfield-china.service@ametek.com

www.brookfieldengineering.cn

For repair or service in Germany, return to:

AMETEK GmbH / B.U. Brookfield
Oberweyerer Str. 21
65589 Hadamar-Steinbach, Germany
Tel.: 06433-9145-4900
Service: 06433-9145-4901
Email (Sales): brookfield.de@ametek.com
Email (Service): brookfield-service.de@ametek.com

www.brookfieldengineering.de

For repair or service in India, return to:

AMETEK Instruments India Pvt. Ltd.
Bhoruka Tech Park 3rd & 4th Floor, Hoody Village,
ITPL Main Rd, Mahadevapura, Bengaluru, Karnataka 560048
Tel: (91) 11/6618-0800
Fax: (91) 11/6618-0836
Email (Sales): brookfield-india.sales@ametek.com
Email (Service): brookfield-india.service@ametek.com

www.brookfieldengineering.in

INDIA COE Office

AMETEK Instruments India Pvt. Ltd.
207-208, A Wing, 215 Atrium,
Andheri Kurla Road,
Behind Hotel Courtyard Marriott,
Andheri (East), Mumbai - 400059

www.brookfieldengineering.in

For repair or service in the United Kingdom, return to:

AMETEK GB LTD T/A Brookfield
Brookfield Technical Centre
1 Stadium Way
Harlow, Essex, CM19 5GX
Tel: +44 (0) 1279-451774
Email (Sales): uk-har.sales@ametek.com
Email (Service): uk-har.service@ametek.com

www.brookfieldengineering.uk

For repair or service in Thailand, return to:

AMETEK (Thailand) Co., Ltd
Bhiraj Tower at Bitec, 23rd Floor,
Sukhumvit Road, Bangna, Bangna
Bangkok 10260 Thailand
Tel : +66(0)83 820 5872
Fax: +66 (0)2 012 7501
Email (Sales): brookfield-thailand.sales@ametek.com
Email (Service): brookfield-thailand.service@ametek.com

store.brookfieldengineering.asia

Onsite service at your facility is available from AMETEK Brookfield. Please contact our Service Department in the United States, United Kingdom, Germany, India, Thailand, or China for details.