

Operating instructions SYCON P-value



Analyser for the automated measurement of the
+p-value

Content

| | |
|--|----|
| General notes | 4 |
| Safety instructions and symbols used | 4 |
| Transport..... | 5 |
| Storage..... | 5 |
| Disposal note..... | 5 |
| SYCON P in detail..... | 6 |
| Scope of delivery | 6 |
| Device description..... | 8 |
| Operating principle..... | 9 |
| General specification | 9 |
| Technical data | 10 |
| Analytical properties..... | 10 |
| Inputs/outputs of the 24 V AC/DC and 230 VAC version..... | 11 |
| Maintenance intervals | 11 |
| Reagents for monitoring the p-value..... | 12 |
| Installation..... | 13 |
| Wall mounting without housing | 14 |
| Wall mounting with housing | 15 |
| Work on pressurised water pipes | 16 |
| Operation with unpressurised sample water..... | 17 |
| Electrical installation | 18 |
| Main board 230 VAC version..... | 19 |
| Main board 24 V AC/DC version..... | 20 |
| Connection of the supply voltage | 21 |
| Connecting the relay outputs | 22 |
| Current interface and RS-485..... | 26 |
| Input contacts 1 and 2..... | 27 |
| Connection of external components | 28 |
| Switch for external analysis start | 30 |
| Connection of a water meter for analyses at volume intervals | 31 |
| Flow monitor / timer..... | 32 |
| Interval reset..... | 33 |
| Input 2 (Input 2) Connection of a switch Error RESET | 34 |
| Reagent lamp/horn | 34 |
| Connecting a control for reagent level warning..... | 36 |
| Relay function analysis active | 36 |
| Limit value mode | 37 |
| Analogue current interface..... | 38 |
| Operating status via analogue current interface..... | 39 |
| Operation | 40 |
| Display and keypad | 41 |
| Display Menu | 42 |
| Menu languages..... | 42 |
| Display indication during a measurement | 43 |
| Display of measured value history..... | 44 |
| Display Selection menu | 44 |
| Display Selection list..... | 44 |
| Display with value input..... | 45 |

Content

| | |
|---|----|
| Configuration..... | 46 |
| Factory settings | 46 |
| Configuration wizard | 47 |
| Menu structure | 61 |
| Operation | 62 |
| Manual and automatic operation | 62 |
| Main menu | 62 |
| Info display..... | 63 |
| Behaviour in the event of a power failure..... | 63 |
| SD card | 64 |
| Maintenance and service | 65 |
| Cleaning the measuring chamber..... | 65 |
| Inserting the "Maintenance Set for SYCON P..... | 66 |
| Reset maintenance counter..... | 68 |
| Changing the reagent bottle | 68 |
| Good and bad counters..... | 69 |
| Calibrating the unit..... | 69 |
| Change battery..... | 70 |
| Software update | 70 |
| Diagnostic functions..... | 71 |
| Display | 71 |
| Sensor | 71 |
| Solenoid valve | 71 |
| Reagent pump | 71 |
| Stirrer blade | 72 |
| Relay 1 to 4..... | 72 |
| Current interface | 72 |
| Entrance 1 and 2..... | 72 |
| Error messages | 73 |
| Analysis does not start | 73 |
| Error message E11 reagent | 73 |
| Error message E12 Water flow..... | 73 |
| Error message E13 Optics | 73 |
| Error message E14 Titration..... | 74 |
| Appendix..... | 75 |
| Spare parts | 75 |
| Maintenance sets | 77 |
| Accessories | 78 |
| Notes..... | 79 |
| Maintenance and service | 79 |
| Settings:..... | 80 |
| Document changes: | 81 |
| Declaration of conformity | 82 |

General notes

These operating instructions describe the installation and operation of the online analyser SYCON P. Installation and commissioning must only be carried out by an authorised specialist.

The unit may only be operated under the conditions described in these operating instructions. The unit may only be used for the specified purpose. When installing and operating the analyser, all locally applicable regulations (such as EN, DIN, VDE, UVV) must be observed.

The switch of the analyser does not disconnect the mains terminals from the power supply. The installation of a suitable electrical disconnecting device is the responsibility of the system operator. Before opening the housing, disconnect the unit from the power supply and secure it against unintentional reconnection.

The analyser is used for the automatic determination of the p-value in the process water. Proper operation can only be guaranteed if the reagents and spare parts recommended by us are used.

Changes to the electrical wiring and programming may only be carried out by a designated specialist.

The water connection lines to the unit should be kept as short as possible and should not be laid together with mains lines or in their immediate vicinity. In the vicinity of strong electromagnetic radiators, interference with the analysis may occur; in this case, separate interference suppression measures must be taken, in particular the EMC guidelines must be observed.

It is recommended to always have access to the analyser when familiarising oneself with the help of these operating instructions in order to be able to understand the explained correlations and functions immediately. Since certain areas build on each other, it makes sense to work through the chapters in the given order.

If you have any questions about the use of the analyser, you will receive support from our partners or from us. You can reach us by telephone during normal business hours or by email. The contact details of our technicians and our partners can be found on our website.

Safety instructions and symbols used

In this operating manual you will find various safety instructions that point out possible risks when handling the analyser. This concerns in detail dangers for

- People,
- this product or associated equipment and installations,
- the working environment.

General notes

Various symbols in these operating instructions indicate special dangers to prevent personal injury and damage to the appliance. Please read the entire text completely before starting work.



This symbol draws your attention to useful tips that contribute to a better understanding of the unit.



This symbol is a general warning that indicates circumstances that must be observed.



Print

This symbol is a warning that you must expect pipes under pressure.



Voltage

This symbol indicates the danger of electric current and the danger to persons and electronic components and assemblies.

Transport



Immediately after receipt, check that the unit is complete and has no transport damage. The analyser is delivered in a transport-safe condition. Nevertheless, damage may occur during transport. Immediately inform the delivery person of any transport damage.



Protect the analyser from possible damage during transport. Remove any liquids still in it beforehand. Remove the reagent bottle and close it to prevent the reagent from leaking.

Storage



Store the analyser in a dry place at temperatures between 0 - 45 °C and out of direct sunlight.

Disposal note

The appliance must not be disposed of with residual waste. Take the unit to a collection point. The battery must be disposed of separately.

Alternatively, you can return the analyser to your dealer or to us for disposal.

SYCON P in detail

The SYCON P online analyser is characterised by the following features:

- Reliable, accurate and fully automatic analyser
- Monitoring of two programmable limit values
- Simple commissioning through configuration wizard
- Self-calibrating and self-monitoring
- Easy maintenance and cleaning
- Compact design
- Multicolour, multilingual graphic display
- Relay output for limit value 1
- Relay output for limit value 2 or reagent alarm
- Relay output for fault indication
- Relay output for feed pump, reagent alarm or cooling water valve
- Analogue output 0/4 - 20 mA for measured value or status message
- 2 programmable digital inputs
- Measurement data memory and measurement data log on SD card
- No formation of condensate in the optics
- Software updates via SD card

Scope of delivery

The SYCON P is available in two versions:

1. *Analyser on wall mount*

The analyser consists of a control unit and the measuring chamber. Both are mounted on a wall bracket. This version is completely functional and contains the connections for the water inlet and outlet as well as a holder to accommodate an reagent bottle (Figure 1).

2. *Analyser in housing*

A plastic housing is available as an option for the analyser on the wall bracket in order to use the analyser in places where more contamination is to be expected (Figure 2). The analyser on wall bracket can be quickly mounted in the housing with 4 screws. If the analyser and housing are ordered together, you will receive the analyser already mounted in the housing.

SYCON P in detail

| Article description | Article number |
|---|----------------|
| SYCON P analyser on wall mount 230 VAC version | 30-010 210 |
| SYCON P analyser on wall mount 24 V AC/DC version | 30-011 211 |
| SYCON P analyser in housing 230 VAC version | 30-210 210 |
| SYCON P analyser in housing 24 V AC/DC version | 30-211 210 |
| Enclosure for SYCON series including wall mounting brackets | 33-099 005 |

The operation of the analyser is menu-driven and intuitive via the graphic display and the 8 keys on the control housing.



Figure 1:
SYCON P on wall bracket



Figure 2:
SYCON P in the housing



The SYCON P analyser on wall bracket is fixed in the housing with 4 screws supplied.

SYCON P in detail

Device description

The analyser consists of the following components: The control unit with graphic display and control panel is located on the left side of the unit. There are 4 cable feed-throughs on the lower control housing. On the right side is the dosing pump and below it the measuring chamber.

The dosing pump is attached to the motor shaft of the motor and engages in the receptacle. It can be removed without tools. The measuring chamber is attached to 2 guide pins on the control housing. It can also be removed without tools and is released with 2 captive locking pins. The metering plugs, actuator plugs, inlet and outlet plugs are attached to the measuring chamber in the same way and can be released quickly.

In the middle is the measuring chamber, which is basically pressureless and always filled to avoid contamination. In the middle of the measuring chamber is the actuator plug with a white high-power LED. The sensor system is located in the housing. Below the measuring chamber is an agitator (magnetic stirrer) that is firmly connected to the housing.

Under the reagent bottle are the water connections for hoses with an outer diameter of 6 mm: inlet with sample water (left) and outlet (right). Both are firmly screwed to the wall bracket.

Behind the reagent bottle there is a solenoid valve in the supply line.



Figure 3: View of the solenoid valve (no reagent bottle installed)



A more detailed description of the components can be found from page 40.

SYCON P in detail

Operating principle

The SYCON P based on the SYCON series is an online analyser for the automatic determination of water parameters according to the colorimetric titration method. By adding a reagent to the water sample, a colour reaction is generated. Depending on the reagent used, the device evaluates the intensity of the colour. Through the colour change of the sample during the addition of the reagent, the SYCON P calculates the concentration of the water ingredient. The device can only determine one parameter at a time. Parameter and measuring range are determined by the reagent used.

General specification

| Parameter | Value / Range |
|---|--|
| Power supply | (230 VAC version) 100 - 240 VAC (50/60 Hz) (24 V AC/DC version) 21.6 - 26.4 V AC/DC (50Hz) |
| Power consumption | 25 VA (in operation) 8 VA (measuring mode) 3.5 VA (standby) |
| Resilience | Load capacity of the relays with internal power supply 1 A from terminals 1 to 4 Load capacity of the relays with external power supply 2.5 A |
| Protection class | Open wall mounting IP43Mounting in enclosure IP54 |
| Storage temperature | 0 °C - 45 °C |
| Ambient temperature | 10 °C - 45 °C |
| Measured water temperature | 5 °C - 40 °C |
| Humidity | 20 - 90 % RF (without ice or condensation) |
| Inlet water pressure | min: 0.5 bar - max: 5 bar / recommendation 1 - 2 bar |
| Inlet water in general | clear, colourless, free of solids, without gas bubbles |
| Water quality requirements for the measurement of the p-value | pH: > 8,2 |

Note on oxidising agents:

Oxidising agents such as calcium hypochlorite, chlorine, chlorine dioxide, sodium hypochlorite or ozone above the limits permitted in "TrinkwV 2012" attack the dye contained in the reagent and interfere with the measurement. This means that an exact determination of the measured value is no longer guaranteed. An activated carbon filter connected upstream of the analyser can remove these oxidants from the sample water and thus enable the correct determination of the measured value.

The capacity of an activated carbon filter is consumed during operation. Therefore, the activated carbon filter must be replaced at regular intervals. The effectiveness of the activated carbon filter can be checked with the help of Caldur® test sets.

SYCON P in detail

Technical data

| Parameter | Value / Range |
|--------------|---|
| Installation | Wall mounting in closed rooms |
| Dimensions | without housing: 274 x 275 x 129 mm (W x H x D) |
| | with housing: 332 x 345 x 190 mm (W x H x D) |
| Weight | without housing: approx. 2.0 kg |
| | with housing: approx. 4.0 kg |

Analytical properties

| Parameter | Value / Range | |
|----------------------------|--|-----------|
| Measuring method | Titration with colour change | |
| Measuring range | P25-5 | P25-20 |
| | mmol/l | 0,2 ... 5 |
| | The measuring range is defined by the reagent used. | |
| Accuracy | Measuring accuracy: $\pm 5\%$ of the maximum measured value of the respective reagent used | |
| | Repeatability: $\pm 2.5\%$ of the maximum measured value of the respective reagent used | |
| | Please note: Depending on the ingredients in the water, there may be shifts in the measured value that affect the measurement accuracy. In such cases, we recommend carrying out a comparison measurement by hand titration and calibrating the analyser to this measured value. | |
| Power interface | ± 0.3 mA | |
| Reagent consumption | approx. 0.05 - 0.6 ml / analysis, depending on the measured p-value | |
| Measuring time | approx. 3 min, depending on the p-value and the set flushing time | |
| Durability of the reagents | min. 12 month with proper storage (< 25 °C, dark) | |
| Water consumption | approx. 1 l / analysis at 2 bar | |
| | The water consumption varies depending on the inlet pressure and the set flushing time. | |

SYCON P in detail

Inputs/outputs of the 24 V AC/DC and 230 VAC version

| Parameter | Value / Range |
|---|--|
| 4 relay outputs | max. 250 VAC / VDC 1 A as potential-free outputs NC/NO the relays provide the following functions: <ul style="list-style-type: none">• Limit value alarm 1• Limit value alarm 2• Device error• Analysis active with switchable delay time• Reagent message |
| 2 signal inputs | galvanically isolated contact input <ul style="list-style-type: none">• Start analysis• Water meter• Flow monitor• Interval reset |
| Analogue output | 0 - 20 mA / 4 - 20 mA Resolution: < 100 μ A max. load: 750 Ω |
| RS-485 | Modbus RTU protocol |
|  | Registers and programming of the interface can be found in the separate manual for the Modbus RTU |

Maintenance intervals

| Interval | Maintenance work |
|---|---|
| every 6 months | Cleaning the measuring chamber |
|  | In case of high ambient and water temperatures or water with a high organic load, the cleaning intervals may have to be shortened. |
| every 30,000 analyses or after 2 years of operation | Cleaning the measuring chamber (as above), Installation Maintenance kit: Change the hose pump cassette and the seals. Resetting the maintenance counter. |

SYCON P in detail

Reagents for monitoring the p-value

| Designation Reagent | Measuring range mmol/l | Item no. 500ml bottle | Item no. 4 x 500 ml bottles |
|------------------------|---------------------------|--------------------------|-----------------------------------|
| P25-5 | 0,2 ... 5 | 32-086 353 | 32-486 353 |
| P25-20 | 0,8 ... 20 | 32-086 354 | 32-486 354 |



The measured value to be monitored should be as close as possible to the middle of the measuring range of the reagent.

The number of possible analyses with one reagent bottle depends on the respective p-value and the reagent used.

Installation

The installation should be done in the following steps to avoid errors:

- Install the analyser in a dry, easily accessible and easily visible place.
- Secure the analyser or the housing stably with screws according to the instructions.
- Connect the unit electrically and make sure that the input voltage is correct. Check the type plate to make sure.
- Connect the inlet and outlet according to the installation instructions. Make sure that the inlet pressure is correct and that the outlet is kept free and short.
- Insert the reagent and connect it to the dosing pump. Make sure that the connecting hoses are not twisted.
- Do not switch on the unit until all preliminary work has been completed and the housing is closed.
- Now make the unit settings on the unit.



The sample water must be clear and free of solids. Otherwise, a filter must be provided upstream of the analyser. Solids in the water can damage the solenoid valve or prevent it from closing. If the solenoid valve blocks or no longer opens or closes, the flow through the measuring chamber will not be correct. This leads to incorrect measurements.



The temperature of the sample water must be between 5 and 40 °C.



If the sample water has a higher temperature, a sample cooler must be used. This is available as an accessory.

Installation

Wall mounting without housing

The SYCON P must be installed in an upright position. There are four 6 mm holes in the wall bracket for mounting the analyser.

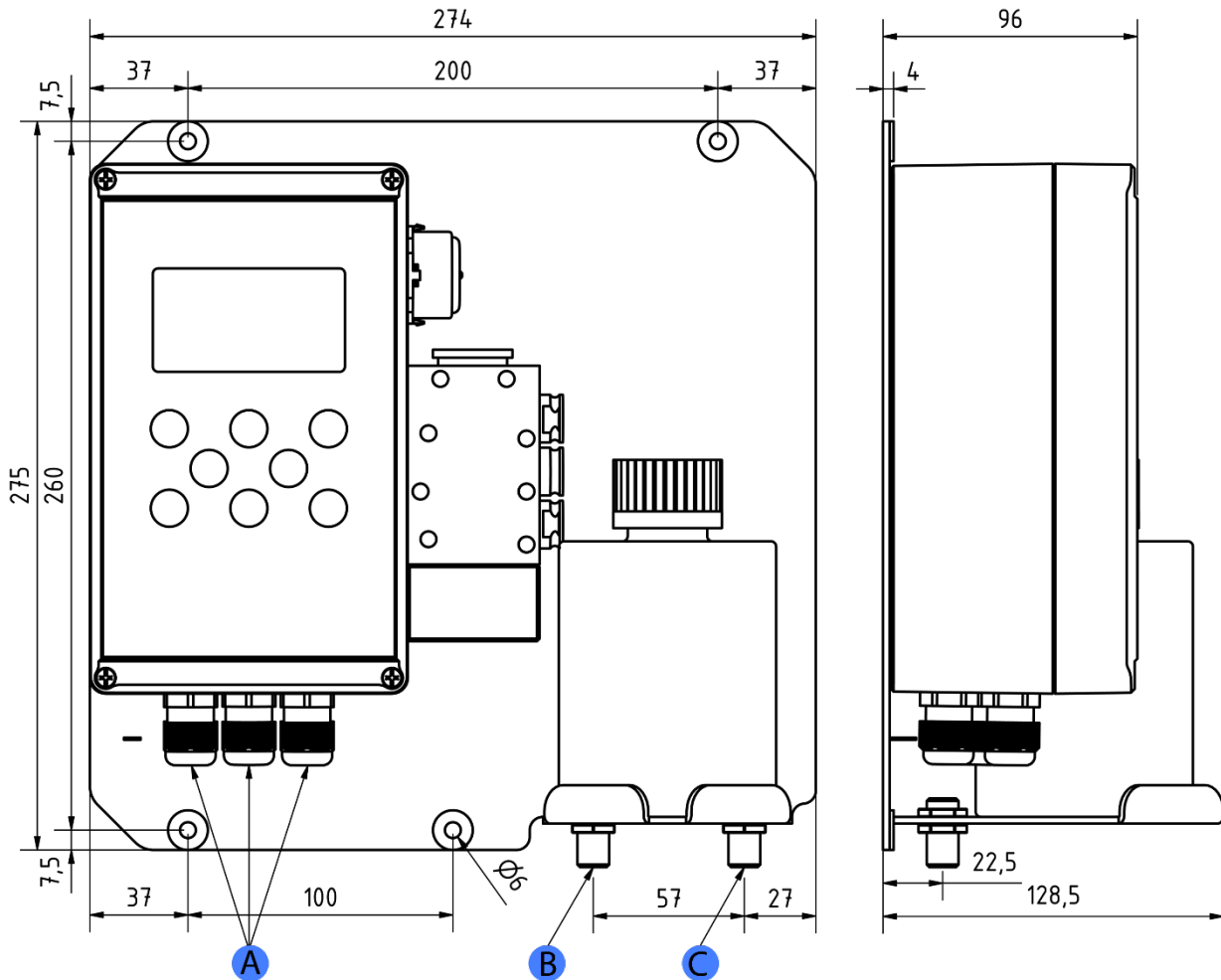

Figure 4 Drilling plan for mounting the analyser without housing

| Position | Description |
|----------|--|
| A | Cable glands for electrical connection |
| B | Water inlet - connection for hose with 6 mm outer diameter |
| C | Water drain - connection for hose with 6 mm outer diameter |

Installation

Wall mounting with housing

The analyser is optionally supplied with a matching housing. As an accessory pack, you will receive 4 mounting brackets with 6.5 mm holes that are attached to the back of the housing. To open the unit, the available free space should be at least 450 x 350 mm (W x H).

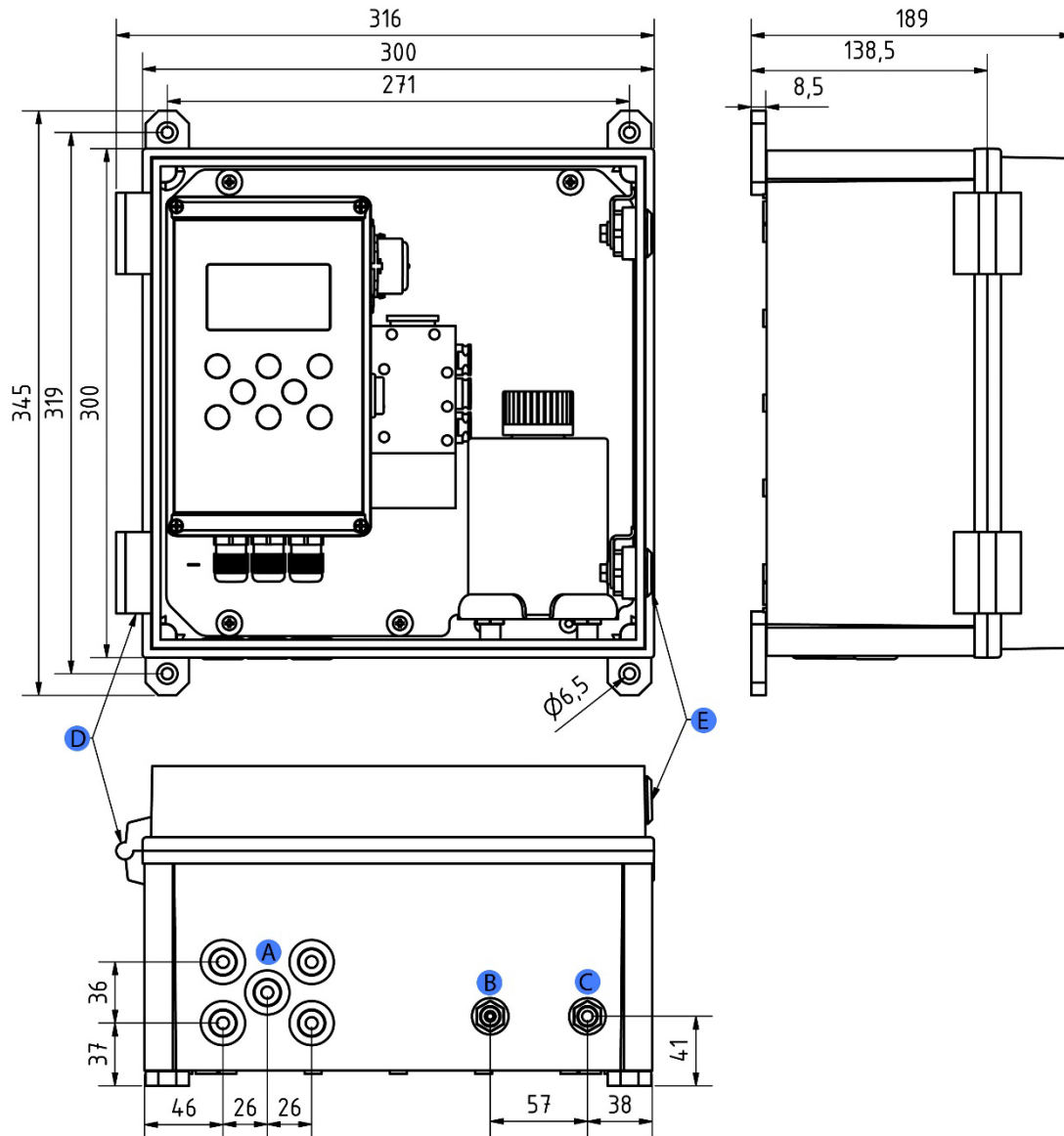

Figure 5 Drilling plan for mounting the analyser in the housing

| Position | Description |
|----------|--|
| A | Cable bushings for electrical connection |
| B | Water inlet - connection for hose with 6 mm outer diameter |
| C | Water drain - connection for hose with 6 mm outer diameter |
| D | Door hinge |
| E | Door latches |

Installation

The fixing lugs can be fitted vertically, as shown in the picture, or rotated by 45° or 90°.

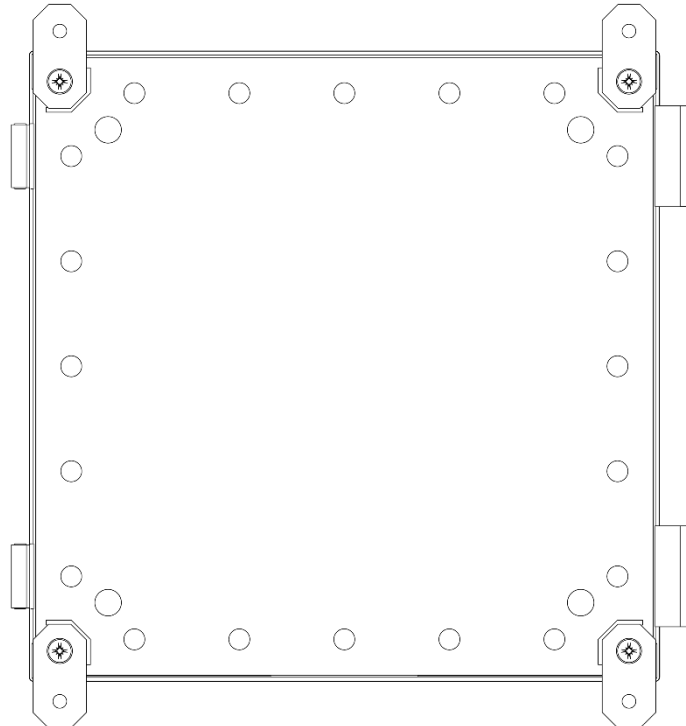

Figure 6: Rear view of the enclosure with mounting brackets mounted vertically

Work on pressurised water pipes



Print

Maintenance and repair work may only be carried out by skilled personnel.

- Before starting work, make sure that all pipes are depressurised.
- Hoses, connections and seals must be checked regularly and, if necessary, replaced as a precaution, even if they show no visible damage. Maintenance intervals must be observed.
- Before commissioning after maintenance, make sure that all connections, screw connections and seals are properly installed. Check that all casing parts are closed and filters or other parts connected to the unit are correctly installed.
- Remove all tools, spare parts or other material required for maintenance before commissioning.
- Clean the unit, absorb any spilled liquids and leave the unit in a clean condition.
- Check that all safety devices are in place and operational.

Installation



The analyser has two connections with bulkhead fittings for plastic hoses with an outer diameter of 6 mm for the water inlet (left) and the water outlet (right). These are simply plugged into the screw connections.

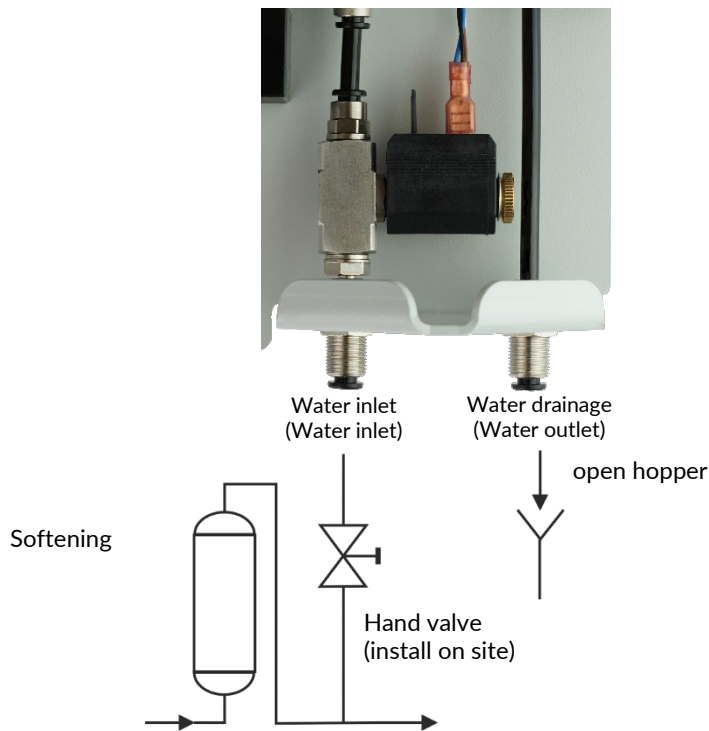

Figure 7: Connecting the water inlet and outlet



Print

The inlet pressure of the water sample must be between 0.5 and 5.0 bar.



The recommended inlet pressure of the water sample should be between 1 and 2 bar.



The hose length of the water drain must not be longer than 2 m and must lead away vertically downwards. The system must be able to relax freely against the atmospheric pressure. There must be no back pressure greater than the inlet pressure. The water is drained without pressure into an open funnel or drain.

Operation with unpressurised sample water

If the sample water is unpressurised, a pressure-controlled diaphragm or submersible pump is required to convey the sample water into the measuring chamber of the analyser.

Electrical installation



Work on electrical connections may only be carried out by authorised specialist personnel in compliance with the current regulations. All lines must be de-energised.

Open the cover of the control unit by loosening the four screws in the corners of the cover.

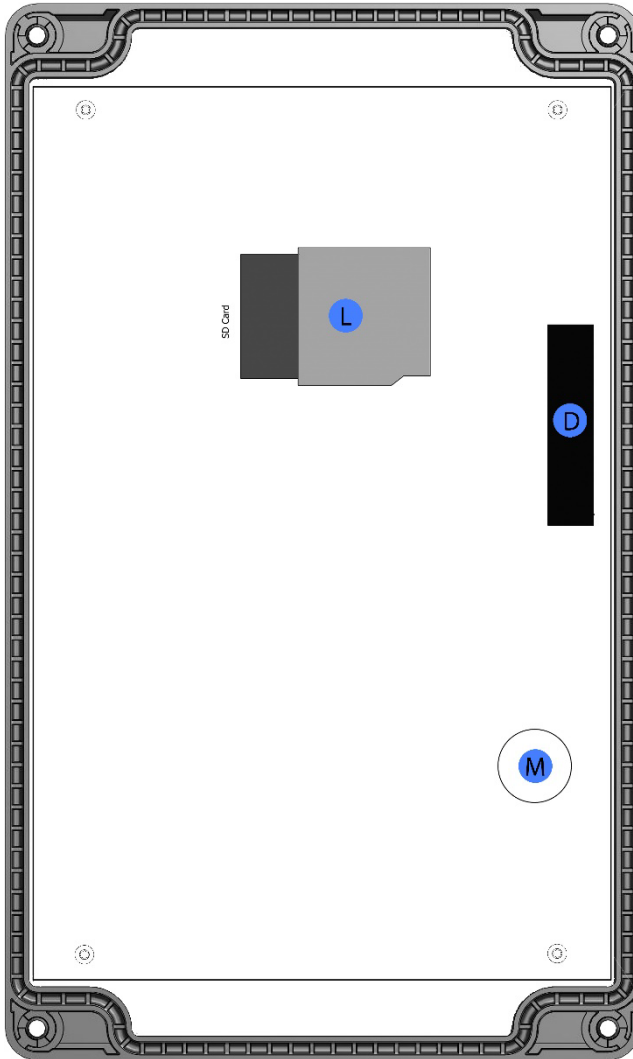
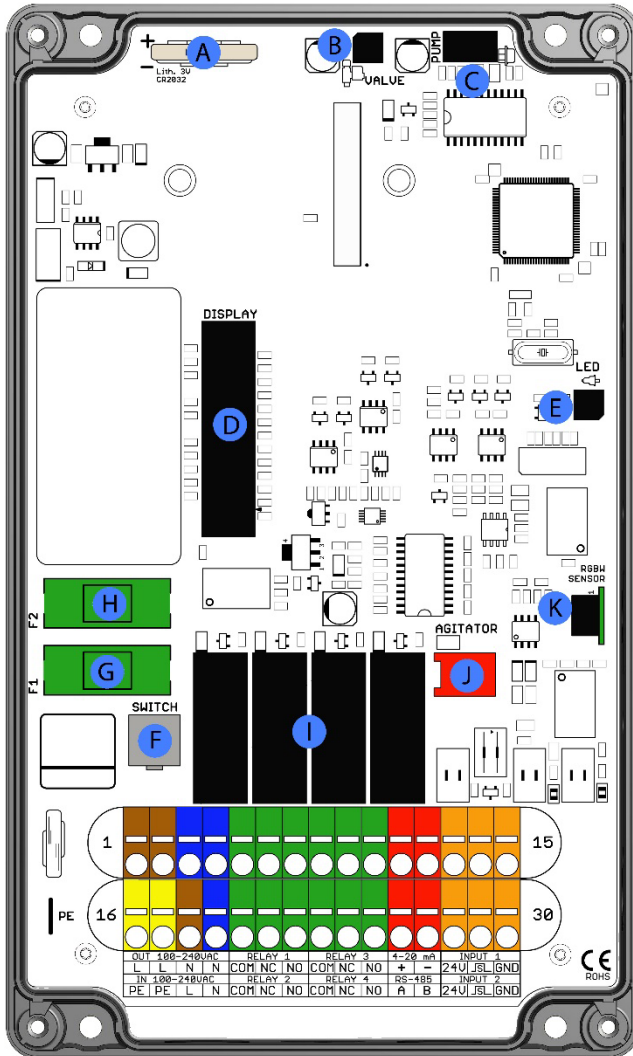

Illustration 8: Back of the cover

| Position | Description |
|----------|------------------------|
| D | Display connection |
| L | SD card socket |
| M | Sound signal generator |

Electrical installation 230 VAC version

Main board 230 VAC version



| Position | Description |
|----------|----------------------------------|
| A | Battery holder |
| B | Solenoid valve connection |
| C | Reagent pump connection |
| D | Display connection |
| E | Actuator plug LED connection |
| F | Main switch connection |
| G | Fuse (5 x 20 mm) 2 A Inert |
| H | Fuse (5 x 20 mm) 400 mA Inert |
| I | 4 x relay |
| J | Agitator connection |
| K | RGB sensor |

Figure 9 Main board 230 VAC version

Electrical installation 24 V AC/DC version

Main board 24 V AC/DC version

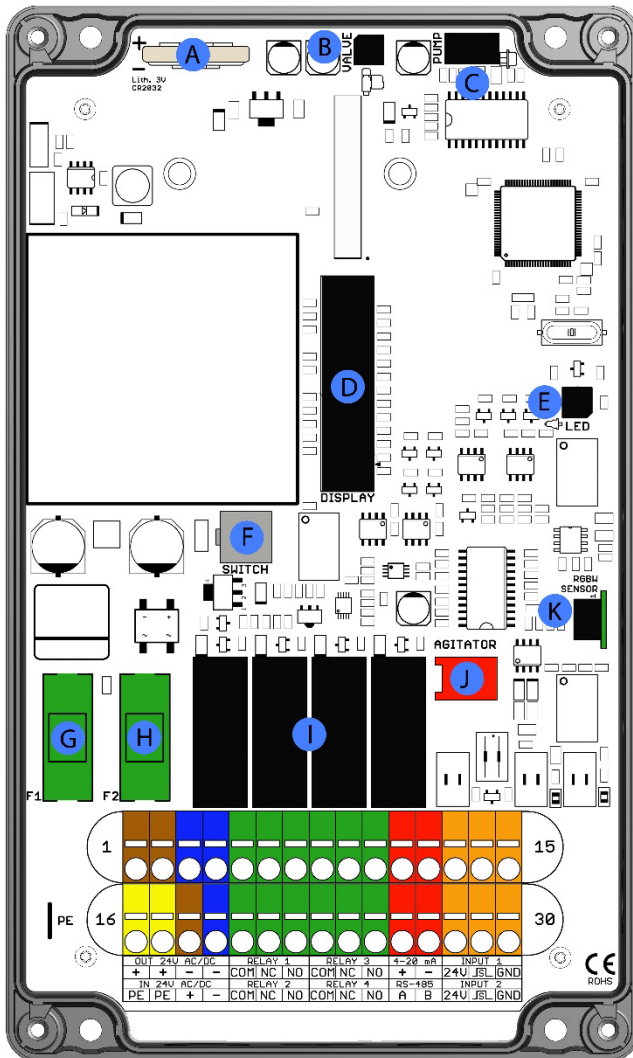

Figure 10 Main board 24 V AC version

| Position | Description |
|----------|-------------------------------|
| A | Battery holder |
| B | Solenoid valve connection |
| C | Reagent pump connection |
| D | Display connection |
| E | Actuator plug LED connection |
| F | Main switch connection |
| G | Fuse (5 x 20 mm) 2 A Inert |
| H | Fuse (5 x 20 mm) 1 A Inert |
| I | 4 x relay |
| J | Agitator connection |
| K | RGB sensor |

Electrical installation

Connection of the supply voltage

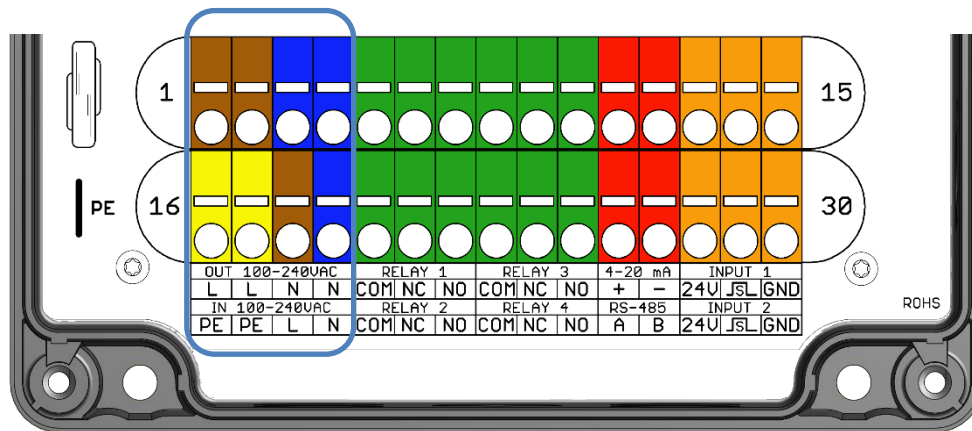

Figure 11: Terminals for connecting the supply voltage (blue border)

Connection of the supply voltage

| Terminal designation | Description |
|----------------------|--------------------------------|
| 16 PE | Grounding |
| 17 PE | Grounding |
| 18 L (power in) | Supply voltage between L and N |
| 19 N (power in) | |

Output terminals switched via the unit switch

| Terminal designation | Description |
|----------------------|---|
| 1 L power out | Switched supply voltage between L and N |
| 2 L power out | |
| 3 N power out | |
| 4 N power out | |



Voltage

The unit switch does not disconnect the terminals from the power supply. Before opening the housing, disconnect the unit from the power supply and secure it against unintentional reconnection.

The installation of a suitable electrical disconnecting device is the responsibility of the system operator.



Voltage

The maximum connected load of all consumers must not exceed 250 VA / 1 A.



Voltage

The protective earth conductor must be connected.

Electrical installation

Connecting the relay outputs

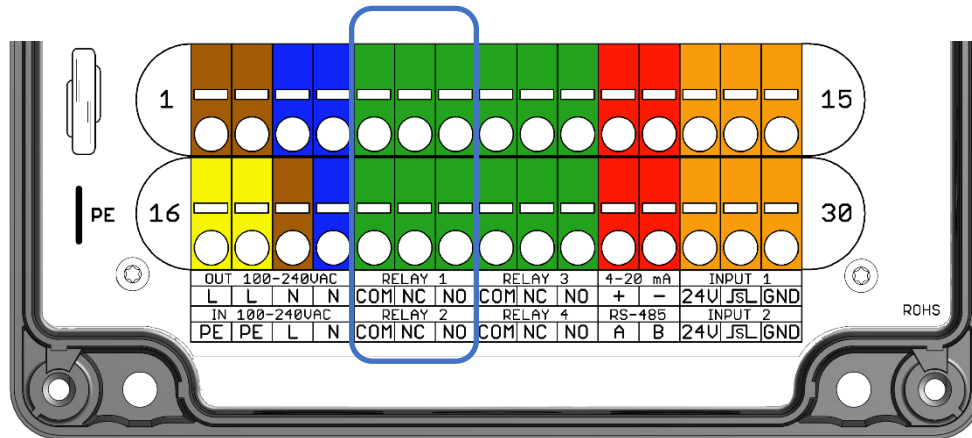

Figure 12: Terminals for connecting the relay outputs (blue border)

The relays are designed as changeover contacts, with a common connection and the switching outputs NC and NO.

RELAY 1 (Relay 1): Limit value alarm 1 / (Upper limit value 1)

| Terminal designation | Description | Connection |
|----------------------|-------------------------------|----------------|
| 5 COM | Relay 1 COM common connection | see page 9 |
| 6 NC | Relay 1 NC normally closed | "Load capacity |
| 7 NO | Relay 1 NO de-energised open | |

Relay 1 Function Limit value alarm 1 / (Upper limit value 1)

If the measured value of the sample is within the target range set in SYCON, relay 1 drops out and establishes a connection from COM to NC. In addition, the symbol R1 is not marked in the display. If the measured value of the sample exceeds the limit value 1 set in SYCON (upper limit value 1), relay 1 is energised and establishes a connection from COM to NO. In addition, the symbol R1 is marked in black in the display.

Electrical installation

RELAY 2 (Relay 2): Limit value alarm 2 / (lower limit value 2) or reagent level warning

| Terminal designation | Description | Connection |
|----------------------|-------------------------------|-----------------|
| 20 COM | Relay 2 COM common connection | |
| 21 NC | Relay 2 NC normally closed | see page 9 |
| 22 NO | Relay 2 NO de-energised open | "Load capacity" |

Relay 2 Function limit value alarm 2 / (lower limit value 2)

The limit value 2 (lower limit value 2) alarm can optionally be triggered when the set limit value is exceeded or not reached.



Note the limit value mode Max/Min or Max/Max.
See "Limit value mode" page 37

Relay 2 Reagent level function:

If the reagent level has fallen below 10%, the reagent level warning is activated. When operating with soft water, a bottle content for 1000 analyses remains when a warning is received.

Alternatively, the function can also be used on relay 4.

If the level of the reagent bottle is above 10%, relay 2 is de-energised and establishes a connection from COM to NC. Additionally, the symbol R2 is not marked in the display.

If the level falls below 10%, relay 2 is energised and establishes a connection from COM to NO. In addition, the symbol R2 is marked in black in the display.

Electrical installation

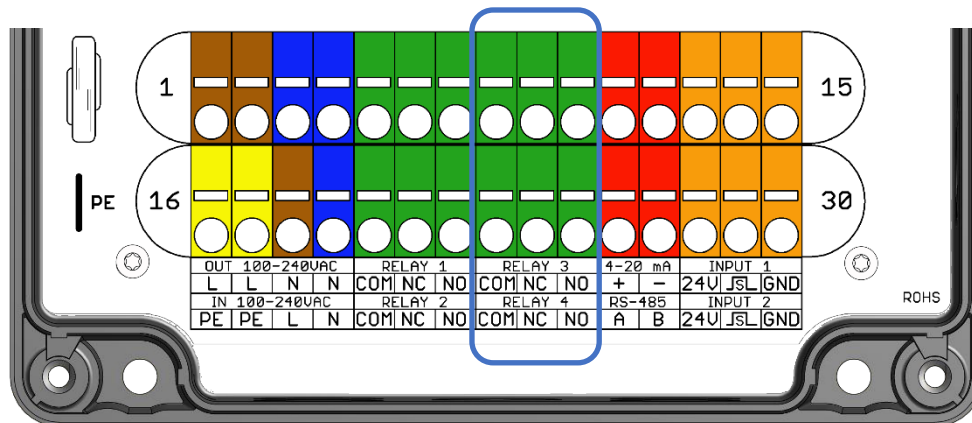

Figure 13: Terminals for connecting the relay outputs (blue border)

RELAY 3 (Relay 3): Device error

| Terminal designation | Description | Connection |
|----------------------|-------------------------------|-------------------------------|
| 8 COM | Relay 3 COM common connection | see page 9 "Load capacity" |
| 9 NC | Relay 3 NC normally closed | |
| 10 NO | Relay 3 NO de-energised open | |

Relay 3 Function Reporting of unit faults:

If a device error occurs or the device is switched off, relay 3 has dropped out (connection from COM to NC). In addition, the symbol R3 is not marked in the display.

Relay 3 is energised in the fault-free device state (connection from COM to NO), this serves to protect against wire breakage. In addition, the symbol R3 is marked in black in the display.



The switching behaviour of relay 3 is inverted. This makes it possible to detect a switched-off device as well as a wire breakage.

Electrical installation

RELAY 4 (Relay 4): Indication of reagent level or control of accessories (analysis delay)

| Terminal designation | Description | Connection |
|----------------------|-------------------------------|-------------------------------|
| 23 COM | Relay 4 COM common connection | see page 9 "Load capacity" |
| 24 NC | Relay 4 NC normally closed | |
| 25 NO | Relay 4 NO de-energised open | |

Relay 4 Reagent level function:

If the reagent level has fallen below 10 %, the reagent level warning is activated. Alternatively, the function can also be used on relay 2.

If the level of the reagent bottle is above 10 %, relay 4 is de-energised and establishes a connection from COM to NC. In addition, the R4 symbol is not marked in the display.

If the level falls below 10 %, relay 4 is energised and establishes a connection from COM to NO. In addition, the R4 symbol is highlighted in black in the display.

Control accessories (analysis delay)

Alternatively, relay 4 can be programmed to the analysis function with optional delay to control the cooling water valve sample cooler, bypass valve or feed pump. The switching state of the relay is shown in the display as R4.

Note on analysis delay

The start of the analysis is delayed. The relay switches already before Analysis start for the set delay time + analysis duration of COM to NO around cooling water valves of sample coolers or pumps to be able to control it.



After the delay time has elapsed, the solenoid valve on the Sycon and the analysis begins. The relay continues to operate for the duration of the Analysis switched.

For more information, see page 36.

Electrical installation

Power interface and RS-485

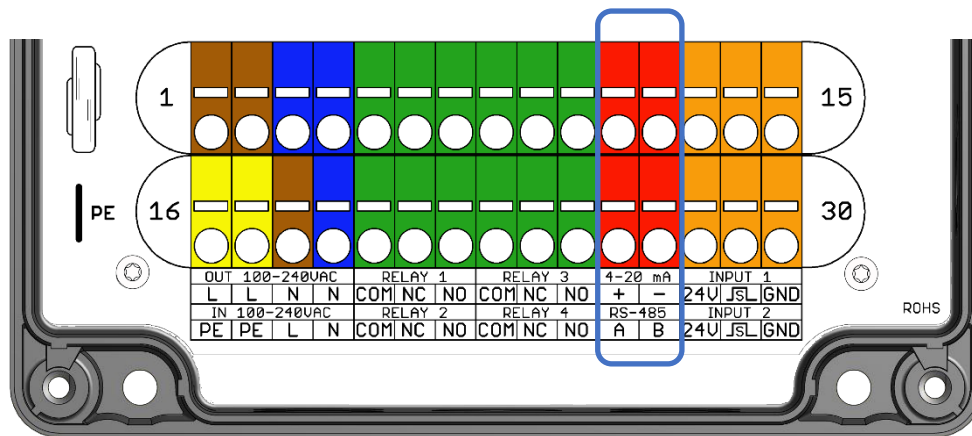

Figure 14: Terminals for connecting the power interface (blue border)

Output 0/4 - 20 mA: Current interface

| Terminal designation | Description |
|----------------------|---------------------------------|
| 11 (+) | + output 0 - 20 mA or 4 - 20 mA |
| 12 (-) | - Output 0 - 20 mA or 4 - 20 mA |

Power interface Function:

The current measured value or the device status is output as a current via the current interface. The current range can be selected between the settings 0 - 20 mA or 4 - 20 mA. The maximum load is 750 Ω.

Current interface selection options Type:

- From
- 0 - 20 mA value
- 4 - 20 mA value
- 0 - 20 mA status
- 4 - 20 mA Status



For more information, see page 39.

RS-485 interface: Modbus

| Terminal designation | Description |
|----------------------|-----------------|
| 26 (A) | Output A RS-485 |
| 27 (B) | Output B RS-485 |

Electrical installation

Input contacts 1 and 2

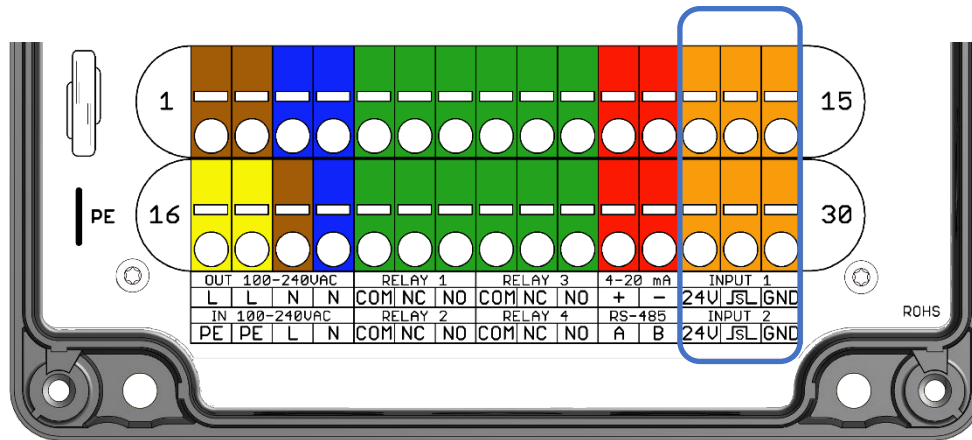

Figure 15: Terminals for connecting the input contacts (blue border)

INPUT 1: Input contact for start analysis / water meter / flow monitor / interval reset

| Terminal designation | Description |
|----------------------|--|
| 13 (24V) | + 24 V auxiliary voltage to connect potential-free outputs |
| 14 (S) | Signal input |
| 15 (GND) | Earth connection for the + 24 V connection |

Input contact 1 Function:

Other potential-free switches can be connected to the input contact. If the input contact is closed, the IN symbol is highlighted in black in the display.



Further information can be found on pages 30 to 33.

INPUT 2: Input contact for remote reset

| Terminal designation | Description |
|----------------------|--|
| 28 (24V) | + 24 V auxiliary voltage to connect potential-free outputs |
| 29 (S) | Signal input |
| 30 (GND) | Earth connection for the + 24 V connection |

Input contact 2 Function:

A control unit can be connected to the input contact to perform a remote reset.



For more information, see page 34.

Connection of external components

For the connection of additional components, the unit is equipped with two inputs (input), 4 relays and an analogue output (current interface 0/4 - 20 mA). A flow monitor, a potential-free switch or an electronic switch (open collector) can be connected to the inputs (input). Electronic or contact water meters can be connected for measurement in a quantity interval. An auxiliary voltage of 24 VDC at terminal 13 and GND at terminal 15 is available for the electronics. For signal detection, 24 VDC must be bridged to terminal 14. No external voltage sources may be connected to the input. If necessary, a potential separation must be made with a relay or optocoupler.

The relay connections are all potential-free. The internal mains voltage or alternatively an external supply voltage can be used to switch external devices. The connection to external controls is usually made via the potential-free contacts of the relays.

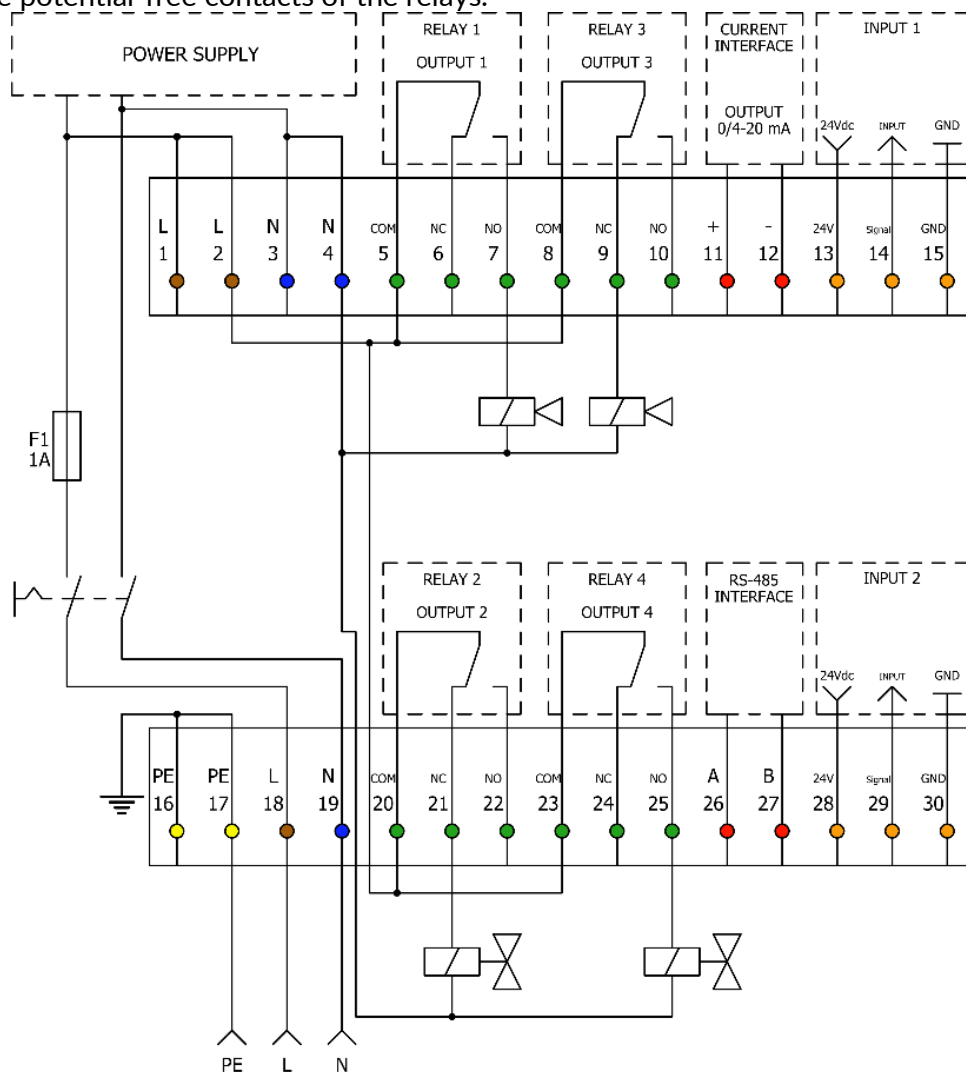

Figure 16 Schematic view of the connection terminals

Connection of external components



Relay 3 is always energised during normal operation: Connection COM to NO (wire breakage safety)



Voltage

The supply voltage switched via the unit switch is applied to output terminals 1 to 4 and can be used at the output relays to control pumps, solenoid valves or other consumers. The maximum total connected load to output terminals 1 to 4 must not exceed 250 VA. The output terminals are switched with the analyser's mains switch and fused by the unit's microfuse.

Connection of external components

Switch for external analysis start

In addition to the possibilities of starting an analysis time-dependently, it is possible to trigger additional analyses via an external button. This can be a potential-free button or the relay output of a PLC control or softening control.

The use of a switch at the input is intended as an addition to the normal time interval. The analyser works in a set time interval, via the switch a signal can be delivered to the input and thus an additional analysis can be started.

(When using this function, the Sycon must be in automatic mode).



An additional analysis can also be triggered by pressing the [OK] key for 3 seconds.



With a permanently connected input contact in analysis start mode, analyses are performed permanently.

Programming: Menu > Settings > Inputs > Input 1 > Start analysis

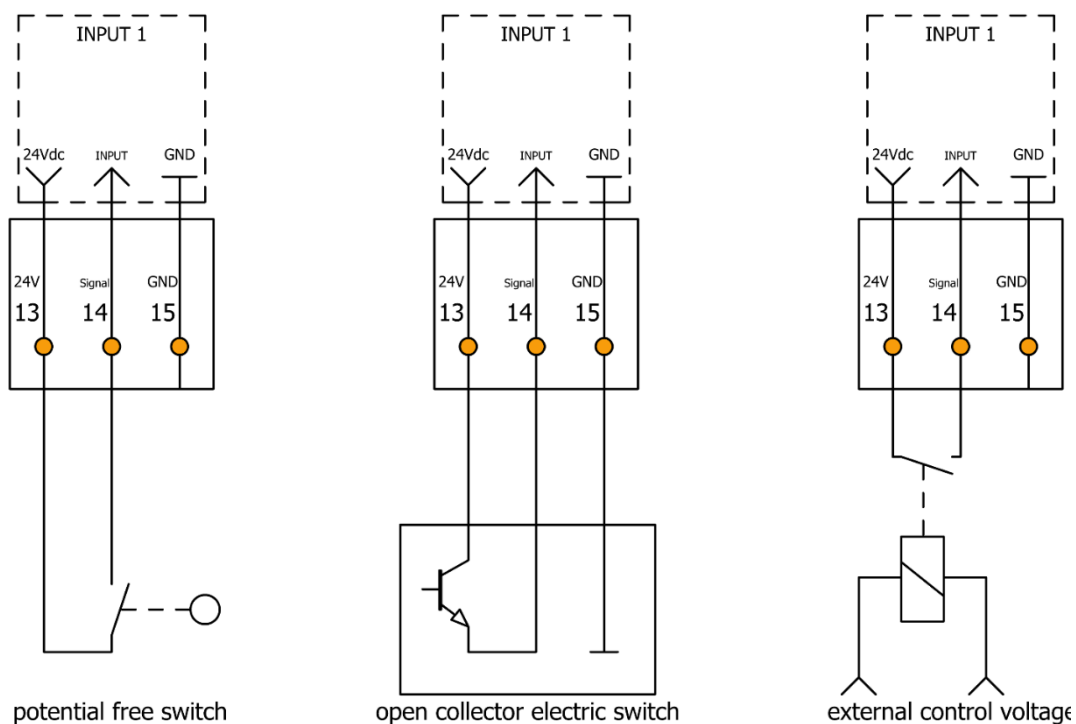

Figure 17 Three possible connection variants around the analyser (1)

Connection of external components

Connection of a water meter for analyses at volume intervals

In addition to the time-dependent triggering of an analysis, there is also the possibility of quantity-dependent triggering. For this, either a contact water meter with a potential-free reed switch or an electronic turbine with a Hall switch is used.

(When using this function, the Sycon must be in automatic mode).

Programming: Menu > Settings > Inputs > Input 1 > Water meter

1. Enter the characteristic data of the water meter used in the unit **litre/pulse**.
2. Enter the type of water meter Hall or Reed. In Reed mode, the input is debounced to prevent miscounting.

Programming: Menu > Settings > Analysis > Auto.Interval Quantity

3. Activate analyses in the quantity interval.
4. Select the unit of measure to be shown in the display.
5. Enter the quantity after which an analysis is to take place.



After switching on the unit, the first analysis is started after 3 minutes. The water quantity count is already active during this time.



The operation of contact water meters (Reed) in the input mode for electronic water meters (Hall) can lead to incorrect interval quantities due to contact bounce.

Programming: Menu > Settings > Inputs > Input 1 > Water meter

Programming: Menu > Settings > Analysis > Auto.Interval Quantity

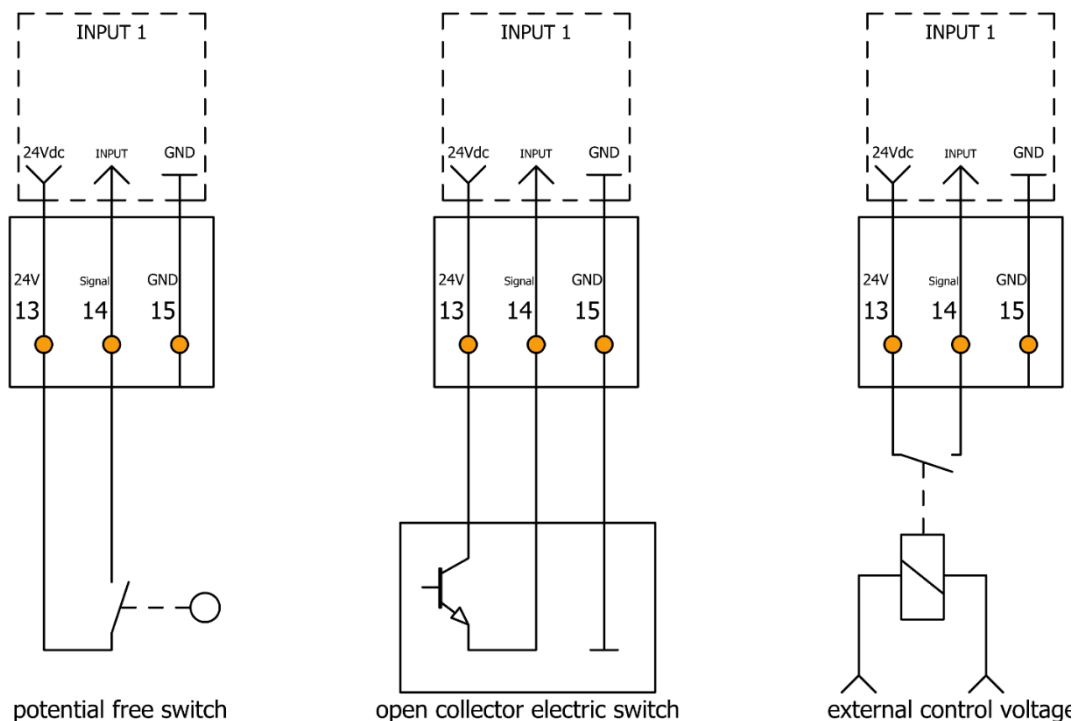

Figure 18 Three possible connection variants around the analyser (2)

Connection of external components

Flow monitor / timer

When installed on a system where monitoring is only necessary during operating hours, the input contact can be used for a flow monitor or a timer. This allows the time interval to be paused during a system shutdown, thus reducing the reagent and power consumption.

A paddle can be used as a flow monitor. The potential-free contact of a timer is also possible. The examples below show different connection options at the input contact.

When using a flow monitor, the analyses are only carried out if a defined signal is present at the input (flow monitor reports flowing water).

Depending on the installed contact, the input can be configured as NC or NO type.

[NO] Analysis interval paused: Next analysis start is waiting for a closed input contact.

[NC] Analysis interval paused: Next analysis start is waiting for an open input contact.

(When using this function, the Sycon must be in automatic mode).

Programming: Menu > Settings > Inputs > Input 1 > Flow monitor



This function must not be confused with the function "Start analysis" by external control.

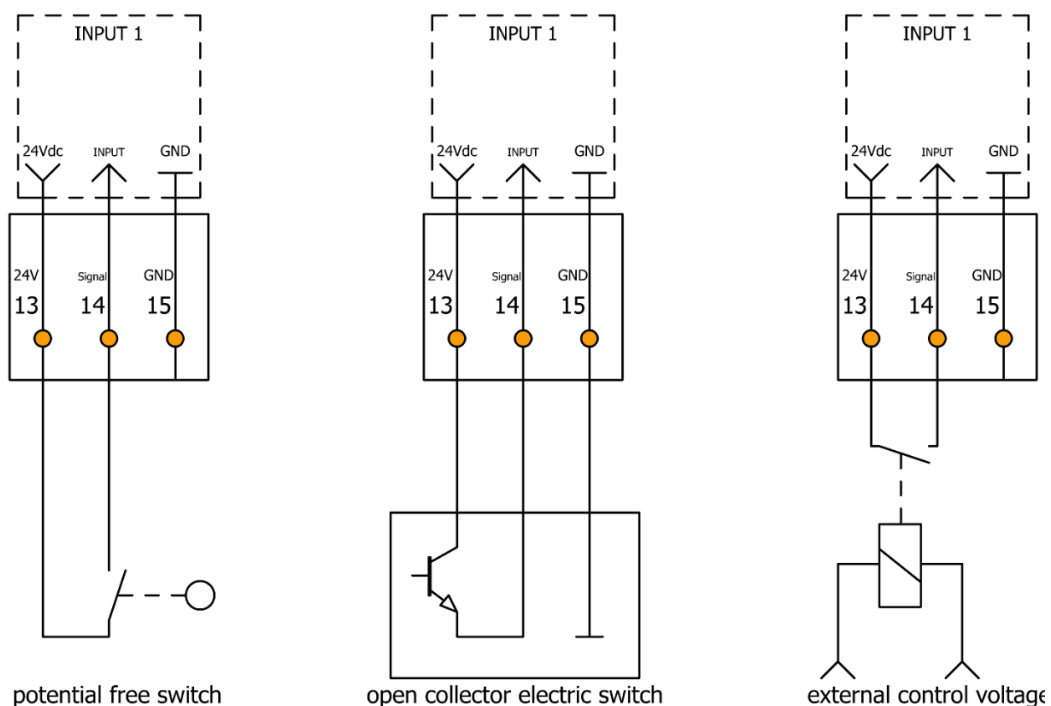

Figure 19 Three possible connection variants around the analyser (3)

Connection of external components

Interval reset

Input IN as interval reset in automatic mode

The interval reset mode is used when monitoring simple or pendulum softening plants. During operation of the softener, the analyses are carried out at the programmed analysis interval. When regeneration starts, the input contact is closed/opened and the analysis and the analysis interval are stopped immediately. The last displayed value is deleted from the display and the analysis interval is paused as long as the input contact is closed/opened.

After completion of the regeneration or after switching over to the second softener, the input contact is closed/opened again. The first analysis starts after one minute. The following analyses are carried out again at the programmed analysis interval.

[NO] Analysis interval active: Analysis interval is stopped by a closed input contact.

[NC] Analysis interval active: Analysis interval is stopped by an open input contact.

(When using this function, the Sycon must be in automatic mode).

Programming: Menu > Settings > Inputs > Input 1 > Interval reset

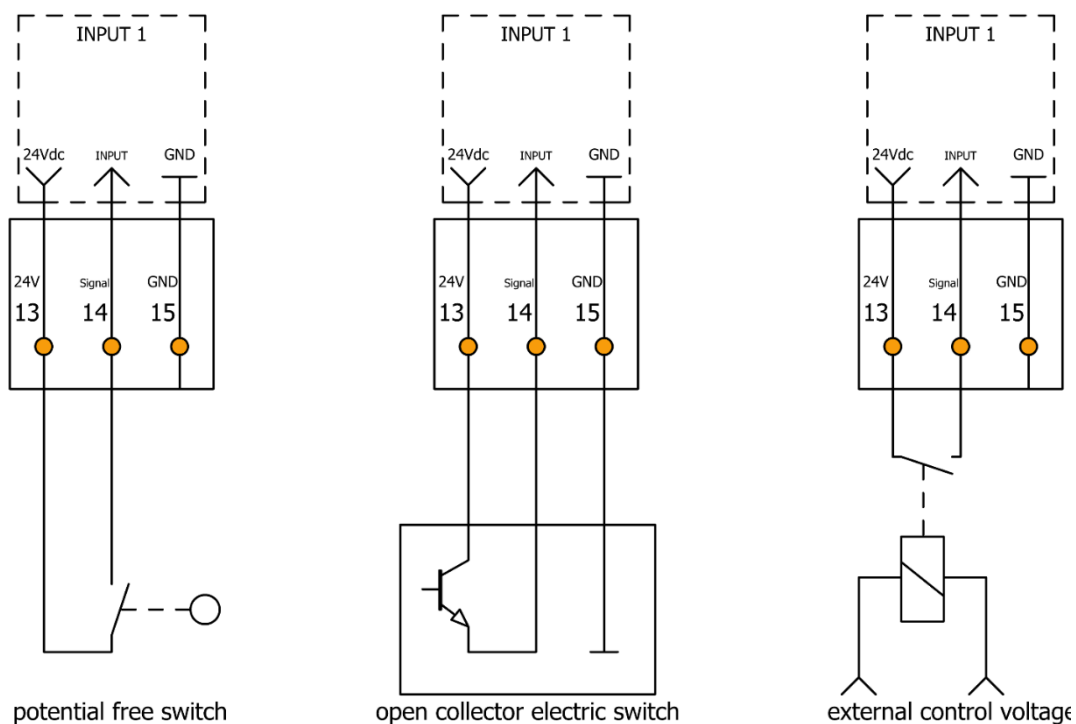

Figure 20 Three possible connection variants around the analyser (4)

Connection of external components

Input 2 (Input 2) Connection of a switch Error RESET

It is possible to cancel analyses in progress or delete error messages from an external switch. This can be a potential-free switch or the relay output of a PLC control or control room.

An auxiliary voltage of 24 VDC at terminal 28 and GND at terminal 30 is available for the electronics. For signal detection, 24 VDC must be bridged to terminal 29. No external voltage sources may be connected to the input. If necessary, a potential separation must be made with a relay or optocoupler.

Programming: no programming required for input 2 / Input 2

Reagent lamp/horn

An reagent light or horn can be connected to relay 1 / output 1 to signal that a limit value has been exceeded.

Relay 3 / Output 3 is used to signal detected errors (e.g. optics error, faulty zero sample, missing supply voltage at the analyser). If the analyser is in normal operation and there is no error, relay 3 / output 3 is energised and the connection from COM to NO is switched. If a fault is detected, relay 3 / output 3 drops out and makes the connection from COM to NC.

Relay 1 / Output 1 is energised when the (Upper limit 1) is exceeded and switches the connection from COM to NO. This position can be programmed in the programme as a permanent contact or as a pulse contact.

Permanent contact on relay 1 / output 1:

The relay 1 / output 1 remains switched in the position (connection from COM to NO) when the limit value is exceeded (upper limit value 1) until the measured value is below the limit value (upper limit value 1) again. Afterwards, the exceeding of the limit value is cancelled again and relay 1 / output 1 switches back (connection from COM to NC).

Pulse contact on relay 1 / output 1:

Relay 1 / Output 1 remains in the position (connection switched from COM to NO) only for a programmed pulse duration if the limit value is exceeded (Upper limit value 1). As soon as the programmed pulse duration has expired, relay 1 / output 1 switches back (connection from COM to NC). When the next limit value is exceeded (upper limit value 1), relay 1 / output 1 is switched again as a pulse. This function is often used in combination with pilot distributors.

Programming: Menu > Settings > Outputs > Relay 1

Connection of external components

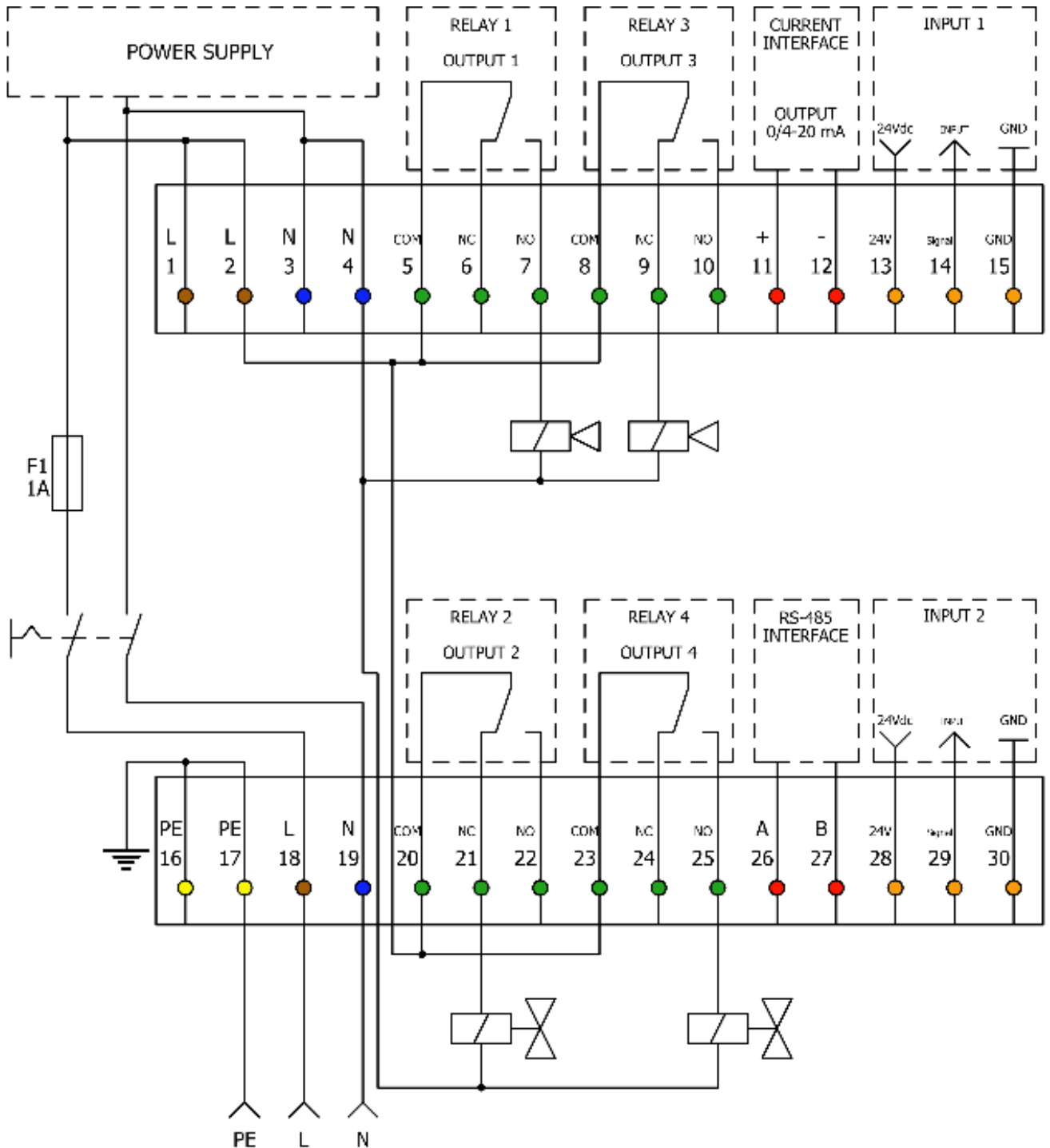

Figure 21: Assignment of the terminals when connecting an reagent lamp/horn

Connection of external components

Connection of a control for reagent level warning

Relay 2 or relay 4 can be used to switch a low reagent level message (reagent level <10%) to a controller or other signal transmitter. For this purpose, relay 2 or relay 4 must be programmed to the reagent low operating mode.

Programming: Menu > Settings > Outputs > Relay 2 > Reagent

Programming: Menu > Settings > Outputs > Relay 4 > Reagent

Relay function analysis active

Relay 4 can be used to signal that an analysis has been started. Signalling devices, pumps or valves can be connected. Connection to a control room is also possible. There is a choice between:

Relay 4 is active during the analysis:

Programming: Menu > Settings > Outputs > Relay 4 > Analysis



In this mode, a feed pump can be connected to the relay, for example, to feed pressure-free sample water into the measuring chamber.

Relay 4 is active before and during analysis:

Programming: Menu > Settings > Outputs > Relay 4 > Analysis > Analysis delay

If selected before and during analysis, the analysis delay is entered in the next step. This time is waited until the unit's solenoid valve opens. This enables functions such as switching cold water on sample coolers.



When using the analysis function to switch cold water on a sample cooler, a manual override of the cold water valve must be provided to prevent hazards to people and material during maintenance or test operation. Design, integration into the safety chain and installation must be carried out in compliance with the applicable standards and laws. Talk to the manufacturer of your steam boiler.

Connection of external components

Limit value mode

Programming: Menu > Settings > Analysis > Limit Mode

Mode: Max/Min (blending device, for monitoring a required range of measured values)

The measured value should be less than limit value 1 (upper limit value 1) and greater than limit value 2 (lower limit value 2). If the measurement result is smaller than limit value 2 (lower limit value 2), the measured value is reported as too low to relay 2.

If the measured value of the sample exceeds the limit value 2 (lower limit value 2), relay 2 drops out and establishes a connection from COM to NC. In addition, the symbol R2 is not marked in the display.

If the measured value of the sample falls below limit value 2 (lower limit value 2), relay 2 is energised and establishes a connection from COM to NO. In addition, the symbol R2 is marked in black in the display.

Mode: Max/Max (softening system, for signalling when limit value 2 (lower limit value 2) is exceeded)

In Max/Max mode, the required measured value is below limit value 1 (upper limit value 1) and limit value 2 (lower limit value 2). Limit value 2 (lower limit value 2) must be programmed smaller than limit value 1 (upper limit value 1). In this way, limit value 1 is used as an alarm message and limit value 2 as a pre-alarm.

If the measured value of the sample falls below limit value 2 (lower limit value 2), relay 2 drops out and establishes a connection from COM to NC. In addition, the symbol R2 is not marked in the display.

If the measured value of the sample exceeds the limit value 2 (lower limit value 2), relay 2 is energised and establishes a connection from COM to NO. In addition, the symbol R2 is marked in black in the display.

Connection of external components

Analogue current interface

The current measured value is available as an analogue value at terminals 11 and 12. Recorders or external devices can be connected to process the measured value. You can choose between a current output 0 - 20 mA value or 4 - 20 mA value. You must also determine which current value of 20 mA corresponds to which measured value.

Programming: Menu > Settings > Outputs > Current interface type

Programming: Menu > Settings > Outputs > Calibrate current interfaces.

(Enter the measured value to correspond to 20 mA.)

The supplied current of the current loop for the displayed measured value is calculated with:

$$I = I_0 + \frac{(20 \text{ mA} - I_0) \cdot \text{Messwert}}{\text{oberer Messwert}} [\text{mA}]$$

Depending on the operating mode, 0 or 4 mA must be used for I_0

The number "upper measured value" corresponds to the entered measured value for 20 mA.

Usually the end of the measuring range of the reagent used is used.



We recommend setting the upper reading to the end of the reagent measuring range.

Connection of external components

Example calculation:

An reagent P25-5 is used for the analysis. Measuring range 0.2 mmol/l to 5 mmol/l.

Upper measured value is set to 5 mmol/l, which corresponds to 20 mA.



For the current interface type "0 - 20 mA", 0 mA corresponds to 0 mmol/l.

For the current interface type "4 - 20 mA", 4 mA corresponds to 0 mmol/l.

Calculation for current interfaces type "0 - 20 mA

$$I = 0 \text{ mA} + \frac{(20 \text{ mA} - 0 \text{ mA}) \cdot 1,2 \text{ mmol/l}}{5 \text{ mmol/l}} [\text{mA}]$$
$$I = 4,8 \text{ mA}$$

4.8 mA corresponds to 1.2 mmol/l.

Calculation for current interfaces type "4 - 20 mA

$$I = 4 \text{ mA} + \frac{(20 \text{ mA} - 4 \text{ mA}) \cdot 1,2 \text{ mmol/l}}{5 \text{ mmol/l}} [\text{mA}]$$
$$I = 7,84 \text{ mA}$$

7.84 mA corresponds to 1.2 mmol/l.

Operating status via analogue current interface

The operating status of the unit can be transmitted via the current interface terminals 11 and 12.

Programming: Menu > Settings > Outputs > Current interface type

Choices:

- 0 - 20 mA status
- 4 - 20 mA Status

| Operating status | Power interface | |
|-----------------------|------------------|------------------|
| | 0 - 20 mA status | 4 - 20 mA Status |
| Operation | 3.5 mA | 6.8 mA |
| Limit value undershot | 7.5 mA | 10.0 mA |
| Limit value exceeded | 12.5 mA | 13.6 mA |
| Reagent level < 10 % | 16.5 mA | 16.8 mA |
| Malfunction | 0 mA | 4 mA |



The specifications listed here may have a deviation of ± 0.3 mA.

Operation



Figure 22: SYCON P analyser with inserted reagent bottle

| Position | Description |
|----------|---|
| A | Control |
| B | Graphic display |
| C | Control panel |
| D | Cable gland |
| E | On / Off switch |
| F | Dosing pump |
| G | Dosing plug (reagent plug) |
| H | Optical measuring path |
| I | Measuring chamber (The locking pins can only be pulled up and not out) |
| K | Stirrer (magnetic stirrer) |
| L | Drain plug |
| M | Actuator plug LED |
| N | Inlet plug |
| O | Solenoid valve (concealed behind the reagent bottle) |
| P | Wall mount |
| Q | Reagent bottle 500 ml |
| R | Water inlet / sample water (push-in connection for plastic hoses with 6 mm outer diameter) |
| S | Water drain (push-in connection for plastic hoses with 6 mm outer diameter) |

Operation

Display and keyboard

The analyser has a graphic display in which both the measured values and the menu for operation can be shown. Depending on the state of the unit, the background colour of the display changes:

| Background colour | State |
|-------------------|------------------------------------|
| White | Unit is working properly |
| Red | Limit value exceeded or unit error |

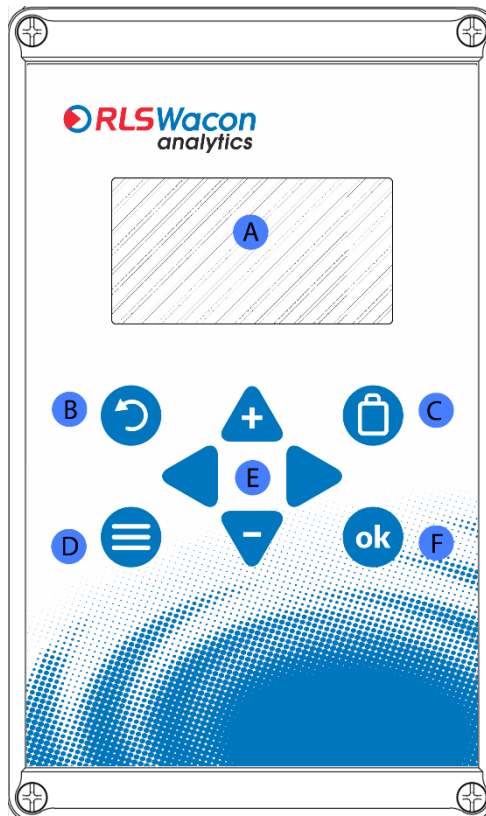

Figure 23: Structure of the front cover of the control unit

Settings can be made via 8 buttons.

| Position | Description |
|----------|--|
| A | Display |
| B | Back / Discard input / Cancel a running analysis |
| C | Inserting a new reagent bottle |
| D | Main menu / Switching between main menu and analysis display |
| E | Arrow keys for navigation / value entry |
| F | OK / Confirm |

Operation

Display indication Menu

The following options are available in the menu window:



Figure 24 Sycon main menu

| Menu item | Description |
|-----------|---|
| Automatic | For activating and deactivating the automatic analysis mode. |
| Settings | All unit settings can be made under this menu item. |
| Info | Informs about: Hardware and software versions, analysis counter, maintenance counter, maintenance date, good and bad measurements. |
| Service | Start analysis (manually), Pump reagent (new bottle inserted), manual rinse, acknowledge maintenance, Reset good and bad counters, Diagnostic programme (testing of the actuators and sensors installed in the SYCON, including the hardware) |
| Wizard | The wizard guides you through all settings in the unit and facilitates commissioning. |
| Course | Displays the history of the last 100 measurements as a diagram. |

Menu languages

The Sycon offers the following languages for operating the analyser.

- German
- English (English)
- French (Français)
- Italian (Italiano)
- Spanish (Español)
- Russian (Русский)
- Polish (Polski)
- Dutch (Dutch)
- Danish (Dansk)

Operation

Display indication during a measurement

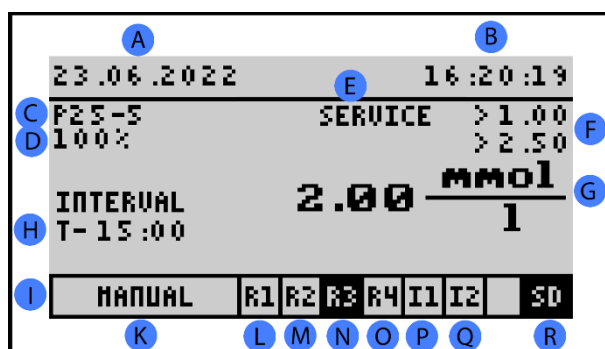

Figure 25Sycon P display

| Position | Description |
|----------|--|
| A | Date |
| B | Time |
| C | Selected reagent |
| D | Bottle fill level in % |
| E | Unit status (Maintenance: Maintenance counter expired, Cleaning: Optics dirty) |
| F | Set limit values |
| G | Analysis result |
| H | Analysis step (T - 5:00 remaining time in minutes until next analysis) |
| I | Status bar |
| K | Manual or automatic operation |
| L | Relay 1 dropped out |
| M | Relay 2 dropped out |
| N | Relay 3 energised (fields with black background are active) |
| O | Relay 4 dropped out |
| P | Digital input (IN 1) inactive |
| Q | Digital input (IN 2) inactive |
| R | SD card available |



Simple analysis start.
Press and hold the [OK] button for 3 seconds to start an analysis.



The analysis start is possible in manual and automatic mode.

Operation

Display of measured value history

Using the arrow keys [◀] and [▶], the last 100 measurements with date and time stamp can be read in the display mode. The set limit value is drawn as a dotted line in the course.



For the evaluation of the measured values on a PC, the file trend.csv is available on the SD card.

You can open the history via the keys Menu > History. Press the [Back] button to return to the measured value display.

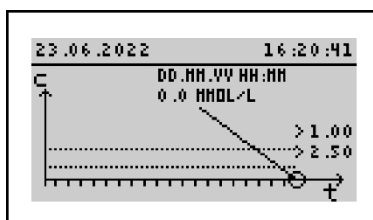

Figure 26: Measured value curve

Display Selection menu

When selecting, you can change the selection with the [◀] and [▶] keys. Confirm the setting with the [OK] key. If you do not want to change the setting, you can leave the selection with the [Back] key.

In the image below, the active selection is the [Yes] button with a black background.

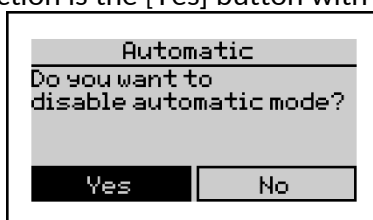

Illustration 27: Selection menu

Display Selection list

In a selection list, you can change the selection with the [▲] and [▼] keys. Confirm the setting with the [OK] key. If you do not want to change the setting, you can leave the selection with the [Back] key. If the selection list offers more than three options, a scroll bar appears on the right edge of the display.

The currently selected input function is marked in black (Start analysis).

The black filled circle to the left of the selection shows which function is currently programmed for the input.

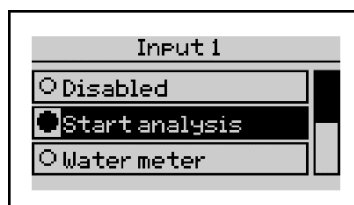

Figure 28: Selection list

Operation

Display with value input

Numbers are entered via a display keyboard. You can move the cursor with the arrow keys [◀], [▶], [▲] and [▼] of the unit. The currently set numerical value and the valid input range are also displayed in the input mask.

You see an input keyboard. Now use the arrow keys to move the black cursor to the desired digit and press the [OK] key.

The selected digit appears in a frame on the left. Repeat the entry until the desired number appears in the frame. Now move the cursor to the OK field on the keyboard and press the [OK] key.

You will see the following information:

Current: currently set value
Minimum: smallest adjustable value
Maximum: largest adjustable value



If the value at "Current" corresponds to your wish, you do not need to enter the number again and can immediately move the cursor to the OK field in the keyboard and confirm with the [OK] key.

In the flush time example below, a flush time between 15 and 1800 seconds can be set. The currently programmed flush time is 120 seconds.

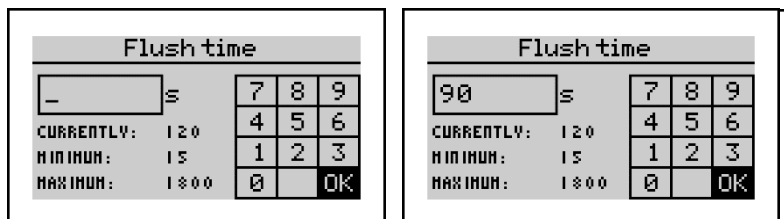

Figure 29: Flushing time

After entering a flush time of 90 seconds, confirming with the [OK] button overwrites the current flush time with 90 seconds.

Configuration

Factory settings

The following factory settings are stored in the unit:

| Menu items | | Factory settings |
|------------|-------------------------|------------------------------------|
| General | Language | German |
| | Unit | mmol/l |
| Analysis | Reagent | P25-5 |
| | Limit value 1 | > 2.5 mmol/l |
| | Limit value 2 | > 1.0 mmol/l |
| | Flushing time | 120 seconds |
| | Auto. Interval Time | 5 minutes |
| | Auto. Interval quantity | No |
| | Stop analysis | No |
| | Control measurement | No repetition |
| Entrance | Calibration factor | 100 % |
| | Input 1 | Start analysis |
| | Input Input 2 | From |
| Outputs | Power interfaces Type | 4 ... 20 mA value |
| | Current interface 20mA | 5 mmol/l |
| | Relay 1 | Limit value 1 as permanent contact |
| | Relay 2 | Limit value 2 as permanent contact |
| | Relay 3 | Reporting errors |
| | Relay 4 | Reagent alarm |



Reset the factory settings with
Programming: Menu > Settings > General > Factory settings

Configuration

Configuration wizard

The configuration wizard simplifies the initial start-up. Menu-driven, the unit guides you step by step through all the necessary settings. It also checks whether the unit is functioning properly.



Later, all settings can be changed again separately in the Menu > Settings.

To start the wizard, select:

Programming: Menu > Wizard



Figure 30: Configuration wizard

The following steps are followed:

| Automatic mode | If the automatic mode is still active, it must be ended now. |
|--------------------|---|
| | Select [Yes] or [No] with the arrow keys [◀] and [▶][confirm with the [OK] key. [Yes] Exits automatic mode. [No] Return to measured value view. |
| Language selection | Please choose your language. / Please choose your language. |
| | Press the [OK] key. |
| | Choice of languages: German, English, Francais, Italiano, Espaniol, Русский, Polski, Dutch and Dansk. Select the language with [▲] and [▼] and confirm with [OK]. |
| Wizard | Do you want to start the configuration wizard? |
| | Select [Yes] or [No] with [◀] and [▶] confirm with [OK]. [Yes] Starts the configuration wizard. [No] Returns to the main menu. |

Configuration

Sicherheit zuverlässig produziert.

Factory settings Do you want to reset the unit to factory settings first?

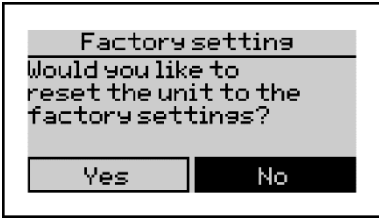

Select [Yes] or [No] with [◀] and [▶] confirm with [OK].
[Yes] Resets the unit to the recommended factory settings.
[No] The unit retains the settings programmed by the user. The factory settings can be found on page 46.

Date Today is the: XX.XX.XX - XX:XX
Do you want to set the date and clock?

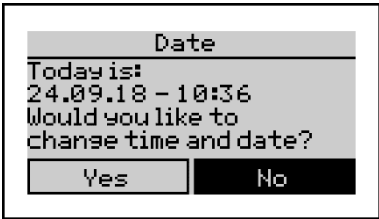

Select [Yes] or [No] with [◀] and [▶] confirm with [OK].
[Yes] Set the date and time.
[No] Device keeps the date and time unchanged.

Set date

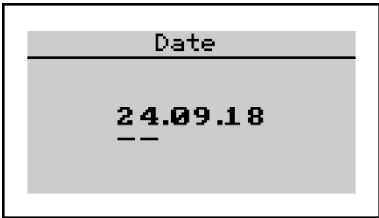

Use the arrow keys [▲] and [▼] to increase or decrease the date.
Confirm with the [OK] key and change step by step from day to month and further to year until the date is set.
Press the [OK] key.

Set time

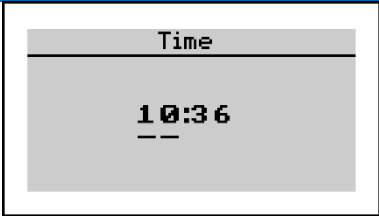

Use the arrow keys [▲] and [▼] to increase or decrease the hour.
Confirm the hour with the [OK] key and programme the minutes in the second step. The seconds are set as 0 seconds at the end.
Press the [OK] key.

Maintenance counter Is maintenance/first installation carried out?

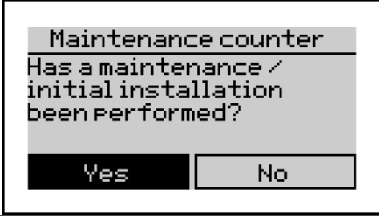

Select [Yes] or [No] with [◀] and [▶] confirm with [OK].
[Yes] Maintenance counter is set to 30,000 analyses and the maintenance date is set to 24 months. (Can be read in the menu > Info)
[No] The unit retains the previous data.

Configuration

Reagent selection

Please select a p-value reagent.

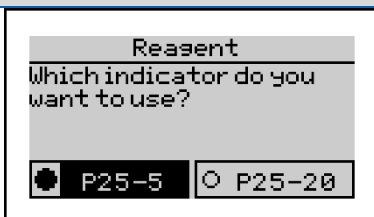

Use [▲] and [▼] to select the reagent P25 used for the p-value determination from the list displayed.

For measuring ranges of the reagents, see the table on page 12.

After selecting, press the [OK] key.

Reagent

Insert a new reagent bottle and press OK.

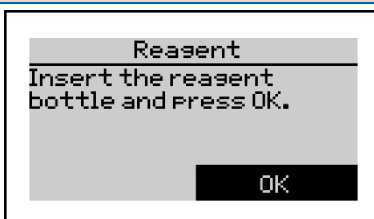

Insert new reagent bottle and press [OK] key.

Reagent

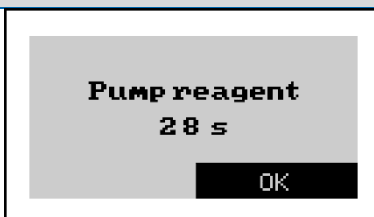

Reagent is pumped into the measuring chamber. The pumping process can be cancelled with the [OK] key before the time has elapsed.



Make sure that the reagent has been pumped into the measuring chamber without bubbles.

Configuration

Reagent

Has a full reagent bottle been used?

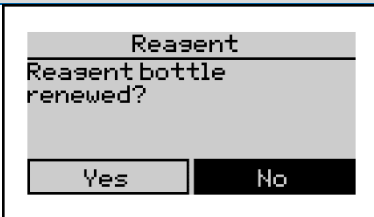

Select [Yes] or [No] with [◀] and [▶] confirm with [OK].

[Yes] The bottle level is set to 100 %.

[No] The previous bottle filling level in % is retained.



If a sample cooler is used, check the proper operation of the sample cooler before the next step in order to exclude a hazard from hot steam or hot water.

Flush

Press OK to flush the supply line and measuring chamber.

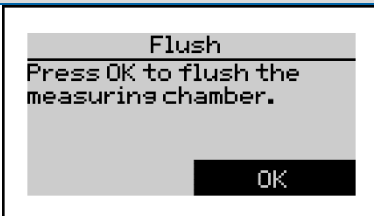

Press the [OK] key.

Flush



The solenoid valve opens and flushes the measuring chamber. The flushing time that has elapsed so far is shown in the display. This can be used as a reference time to set the flushing time before an analysis. The flushing process is terminated with the [OK] key. The solenoid valve closes.



Make sure that the sample water is clear and free of bubbles.

Configuration

Flushing time

Set the rinsing time in the following screen.

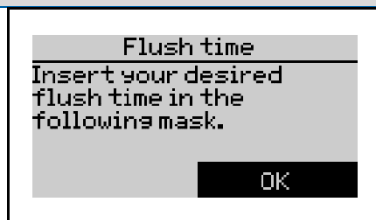

Press the [OK] key.

Flushing time

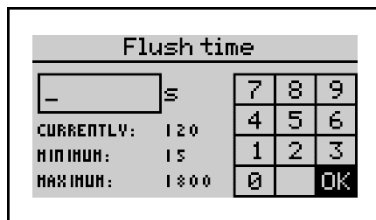

Use the arrow keys [◀], [▶], [▲] and [▼] move the black cursor to the desired digit and press the [OK]

The selected digit appears in a frame on the left.

Repeat the entry until the desired flushing time appears in the frame.

Now move the cursor to the OK field on the keyboard and press the [OK] key.



You will see the following information on the left:

Current: currently programmed value

Minimum: smallest adjustable value

Maximum: largest adjustable value



If the value at "Current" corresponds to your wish, you do not need to enter the digits again and can immediately move the cursor to the OK field in the keyboard and confirm with the [OK] key.

Limit Mode

Select the mode for limit value 1 / limit value 2

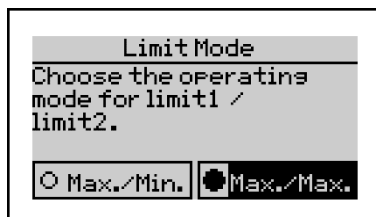

In Max./Max. mode, the measurement is considered good if the measurement results in a value below the programmed limits. This mode is used for softening systems. In Max./Min. mode, the measurement is considered good if the measurement result is between limit value 1 and limit value 2. This mode is used for water cutting systems.

The value of limit value 2 must be lower than limit value 1.

Press the [OK] key.

(Further information on page 37)

Limit value 1

Enter the upper limit value 1 which, if exceeded, should switch relay 1.

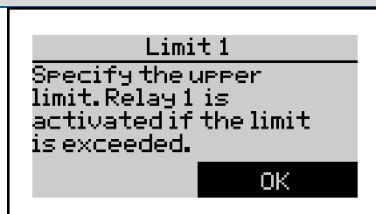

Press the [OK] key.

Configuration

Limit value 1

| Limit 1 | | | | |
|------------|------|---|---|----|
| - | mmol | 7 | 8 | 9 |
| | 1 | 4 | 5 | 6 |
| CURRENTLY: | 1.00 | 1 | 2 | 3 |
| MINIMUM: | 0.20 | 0 | . | OK |
| MAXIMUM: | 5.00 | | | |

You will see an input keyboard on the right. Now use the arrow keys [◀], [▶], [▲] and [▼] to move the black cursor to the desired digit and press the [OK] key. The selected digit appears in a frame on the left. Repeat the entry until the desired limit value appears in the frame. Now move the cursor to the OK field on the keyboard and press the [OK] key.



You will see the following information on the left:
Current: currently programmed value
Minimum: smallest adjustable value
Maximum: largest adjustable value



If the value at "Current" corresponds to your wish, you do not need to enter the number again and can immediately move the cursor to the OK field in the keyboard and confirm with the [OK] key.

Limit value 2

Enter the lower limit value 2, which relay 2 is to be switched when it is exceeded/fallen short of.

| Limit 2 | |
|---|----|
| Specify the lower limit. Relay 2 is activated if the limit is exceeded. | OK |

Press the [OK] key.

Limit value 2

| Limit 2 | | | | |
|------------|------|---|---|----|
| - | mmol | 7 | 8 | 9 |
| | 1 | 4 | 5 | 6 |
| CURRENTLY: | 2.50 | 1 | 2 | 3 |
| MINIMUM: | 0.20 | 0 | . | OK |
| MAXIMUM: | 1.00 | | | |

You will see an input keyboard on the right. Now use the arrow keys [◀], [▶], [▲] and [▼] to move the black cursor to the desired digit and press the [OK] key. The selected digit appears in a frame on the left. Repeat the entry until the desired limit value appears in the frame. Now move the cursor to the OK field on the keyboard and press the [OK] key.



You will see the following information on the left:
Current: currently programmed value
Minimum: smallest adjustable value
Maximum: largest adjustable value



If the value at "Current" corresponds to your wish, you do not need to enter the number again and can immediately move the cursor to the OK field in the keyboard and confirm with the [OK] key.

Configuration

Auto. interval Time

Do you want the analyses to be carried out at a time interval?

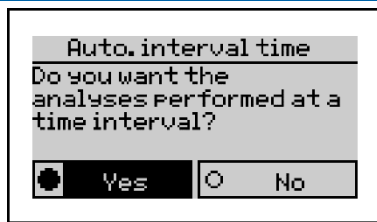

Select [Yes] or [No] with [◀] and [▶] confirm with [OK].

- [Yes] Analyses are carried out at an automatic time interval.
- [No] Do not perform analyses in the automatic time interval.

Auto. interval Time

Set the Auto. Interval Time at which the analyses are to be carried out.

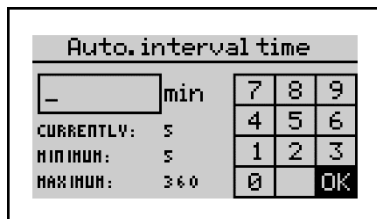

You will see an input keyboard on the right.

Now use the arrow keys [◀], [▶], [▲] and [▼] to move the black cursor to the desired digit and press the [OK] key. The selected digit appears in a frame on the left. Repeat the entry until the desired analysis interval time appears in the frame. Now move the cursor to the OK field on the keyboard and press the [OK] key.



You will see the following information on the left:

- Current: currently programmed value
- Minimum: smallest adjustable value
- Maximum: largest adjustable value



If the value at "Current" corresponds to your wish, you do not need to enter the number again and can immediately move the cursor to the OK field in the keyboard and confirm with the [OK] key.

Control measure

How often should a limit value violation be verified before reporting?

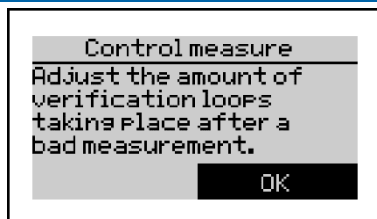

Press the [OK] key.

Control measure

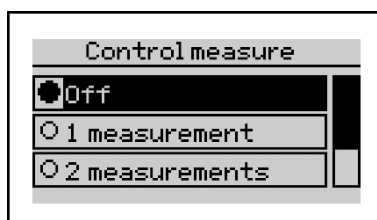

Use [▲] and [▼] to set the number of control measurements to be carried out before a limit value is exceeded is reported. These are carried out at 3-minute intervals after a limit value has been exceeded in order to avoid false alarms due to the counter ion effect of the softening system.

Make your selection and confirm with the [OK] key.

Configuration

Analysis stop

Car. Stop interval after limit value exceeded?

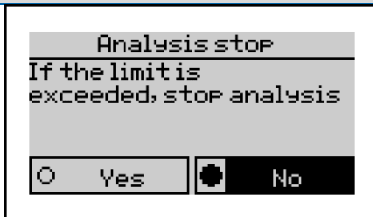

Select [Yes] or [No] with [◀] and [▶] confirm with [OK].
[Yes] Auto. Interval is paused after a limit value is exceeded. (To carry out further analyses, the automatic mode must be activated again on the device).
[No] Further analyses are carried out even after the limit value has been exceeded.

Entrance 1

Select the function of the input.

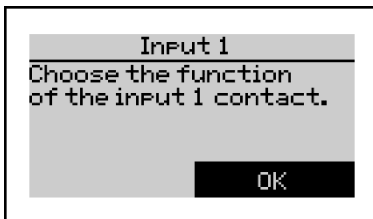

Press the [OK] key.

Input 1

You have the following choices at the entrance:

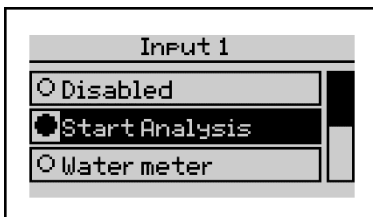

- Disabled
- Start analysis
- Water meter for quantity interval
- Flow monitor for analyses during operating time
- Interval reset for softener switchover

Make your selection and confirm with the [OK] key.

Start analysis when selected

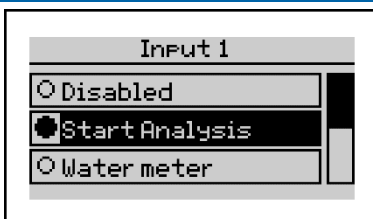

An analysis is started as soon as the "INPUT 1: Input contact" terminal 13 is bridged to terminal 14.

(When using this function, the Sycon must be in automatic mode).

Configuration

For water meter selection

Enter the litres/pulse of your water meter.

Input 1

- Start Analysis
- Water meter
- Flow switch

Liter / pulse

Enter the liter / pulse of your flow meter.

OK

Liter / pulse

| | | | |
|------------------|---|---|----|
| 1/P. | 7 | 8 | 9 |
| CURRENTLY: 10.00 | 4 | 5 | 6 |
| MINIMUM: 0.01 | 1 | 2 | 3 |
| MAXIMUM: 1000.00 | 0 | . | OK |

Contact type

Choose the output type of the flow meter.

- Reed
- Hall

Auto. interval amount

Choose the water volume between two analysis.

OK

Unit

- l
- hl
- m3

Auto. interval amount

| | | | |
|----------------|---|---|----|
| 1 | 7 | 8 | 9 |
| CURRENTLY: 100 | 4 | 5 | 6 |
| MINIMUM: 1 | 1 | 2 | 3 |
| MAXIMUM: 9999 | 0 | | OK |

You will see an input keyboard on the right. Now use the arrow keys [◀], [▶], [▲] and [▼] to move the black cursor to the desired digit and press the [OK] key. The selected digit appears in a frame on the left.

Repeat the entry until the desired number appears in the frame.

Now move the cursor to the OK field on the keyboard and press the [OK] key.

(When using this function, the Sycon must be in automatic mode).



You will see the following information on the left:

Current: currently programmed value

Minimum: smallest adjustable value

Maximum: largest adjustable value

If the value at "Current" corresponds to your wish, you do not need to enter the digits again and can immediately move the cursor to the OK field in the keyboard and confirm with the [OK] key.

Is the water meter a "reed" or "hall" contact type?

Reed for potential-free water meter

Hall for electronic water meters

Make your selection and confirm with the [OK] key.

Set the amount of water after which an analysis is to take place.

Press the [OK] key.

Set the unit.

Set the amount of water after which an analysis is to take place.



You will see the following information on the left:

Current: currently programmed value

Minimum: smallest adjustable value

Maximum: largest adjustable value

If the value at "Current" corresponds to your wish, you do not need to enter the digits again and can immediately move the cursor to the OK field in the keyboard and confirm with the [OK] key.

Configuration

If flow monitor is selected

Is the flow monitor a NC or NO type?

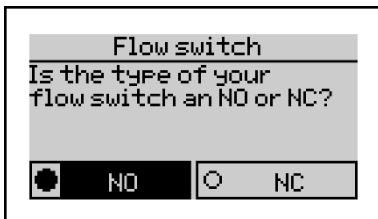
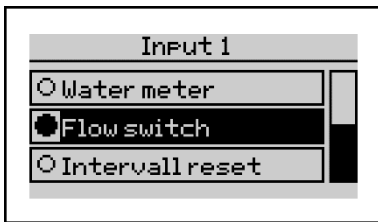

[NO] Analysis interval paused: Next analysis start is waiting for a closed input contact.

[NC] Analysis interval paused: Next analysis start is waiting for an open input contact.

Make your selection and confirm with the [OK] key.

(When using this function, the Sycon must be in automatic mode).

If interval reset is selected

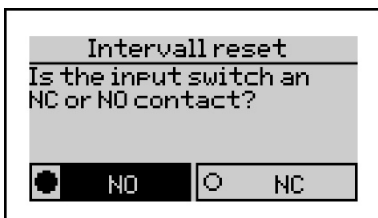
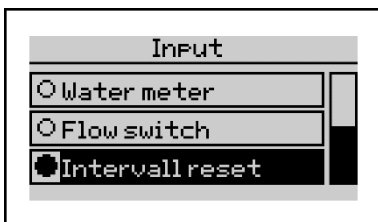

[NO] Analysis interval active: Analysis interval is stopped by a closed input contact.

[NC] Analysis interval active: Analysis interval is stopped by an open input contact.

Make your selection and confirm with the [OK] key.

If the analysis interval is stopped, then the analyses are stopped immediately and paused as long as the input contact remains closed/open.

As soon as the input contact is opened/closed, the analysis interval begins. However, since there is no display value in the display yet, the first analysis is carried out after 1 min before the set analysis interval (e.g. 5 min) begins.

(When using this function, the Sycon must be in automatic mode).

Configuration

Entrance 2

Input 2 (input 2) is used to reset the unit in case of an error.

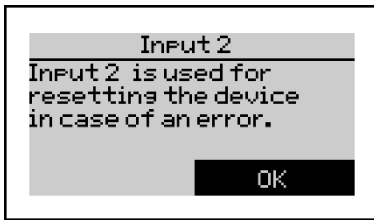

Input 2 can be used to reset the unit in the event of a unit malfunction.

Confirm with [OK] key.

Relay 1

Do you need a permanent or pulse contact at relay 1 / limit value?

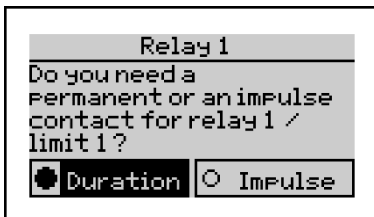

Select [Duration] or [Pulse] and press the [OK] button.
[Duration] The relay switches to permanent contact if the limit value is exceeded until an analysis is carried out that falls below the limit value.

[Pulse] The relay switches for a set pulse time.

If pulse contact is selected

Set the pulse duration for relay 1.

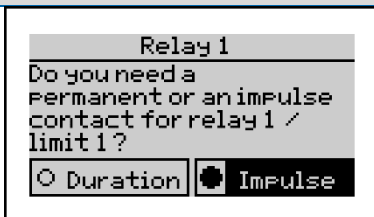

You will see an input keyboard on the right. Now use the arrow keys [◀] and [▶] to move the black cursor to the desired digit and press the [OK] key.

The selected digit appears in a frame on the left.

Repeat the entry until the desired pulse duration appears in the frame.

Now move the cursor to the OK field on the keyboard and press the [OK] key.

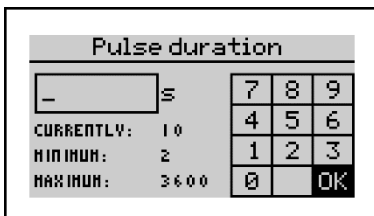

You will see the following information on the left:

Current: currently programmed value

Minimum: smallest adjustable value

Maximum: largest adjustable value



If the value at "Current" corresponds to your wish, you do not need to enter the number again and can immediately move the cursor to the OK field in the keyboard and confirm with the [OK] key.

Configuration

Relay 2

Configure relay 2 for the function limit value 2 or reagent level <10%?

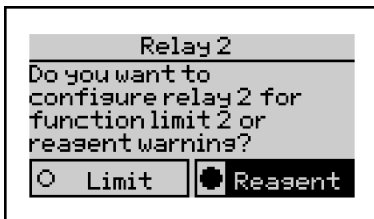

Select [Limit] or [Reagent] and press the [OK] key.

[Limit] The relay switches when the limit value is exceeded or not reached.
(For more info see page 37)

[Reagent] The relay switches when the reagent level falls below 10 % residual content.

If limit value is selected

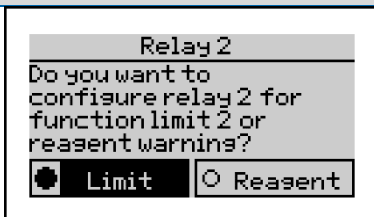

The relay switches when the limit value is exceeded/fallen short of.

(For more info see page 37)

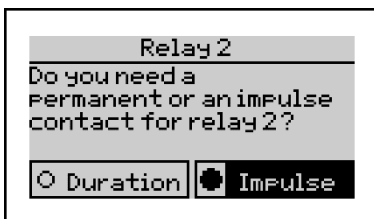

Select [Duration] or [Pulse] and press the [OK] key.

[Duration] The relay switches to permanent contact if the limit value is exceeded/fallen short of until an analysis is carried out that exceeds/falls short of the limit value.

[Pulse] The relay switches for a set pulse time.

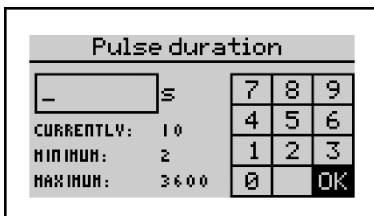

You will see an input keyboard on the right. Now use the arrow keys [◀], [▶], [▲] and [▼] to move the black cursor to the desired digit and press the [OK] key.

The selected digit appears in a frame on the left.

Repeat the entry until the desired pulse duration appears in the frame.

Now move the cursor to the OK field on the keyboard and press the [OK] key.

If the value at "Current" corresponds to your wish, you do not need to enter the number again and can immediately move the cursor to the OK field in the keyboard and confirm with the [OK] key.

Relay 3

Relay 3 is used to indicate a unit error.

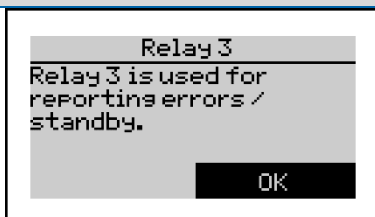

Relay 3 is used to indicate a unit error and cannot assume any other functions.

Press the [OK] key

Relay 3 is always energised in normal operation, connection COM to NO (wire breakage safety).

In the event of a device error, relay 3 drops out and establishes the connection COM to NC.



Configuration

Relay 4

Select the switching function for relay 4.

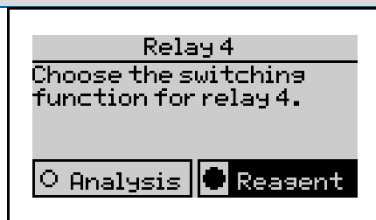

Select [Analysis] or [Reagent] and press [OK].

[Analysis.] The relay switches during the analysis.
 [Reagent] The relay switches when the level falls below the reagent level of 10% residual content.

On selection Analysis

Should maintenance be carried out before opening the solenoid valve?

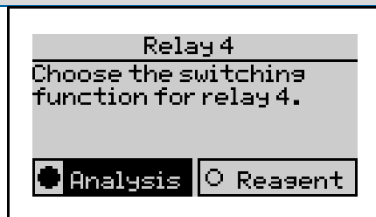

Select [Yes] or [No] and press the [OK] key.

[Yes] The start of the analysis is delayed. The relay switches from COM to NO before the analysis starts for the set delay time + analysis duration in order to be able to control the cooling water valves of the sample coolers or pumps. After the delay time has elapsed, the solenoid valve on the Sycon opens and the analysis begins. The relay remains switched for the duration of the analysis.

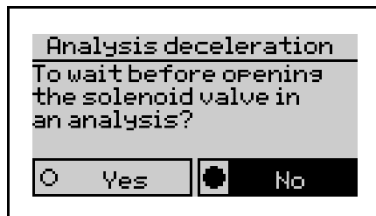

[No]

The relay only switches from COM to NO for the duration of the analysis (no delay time).

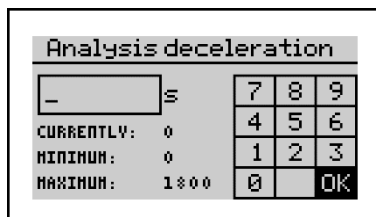

Enter the delay time in seconds to wait before starting an analysis and opening the solenoid valve.

Confirm the entered value with [OK].

(For more information, see page 36)

Power interfaces Type.

Select the operating mode of the power interface.

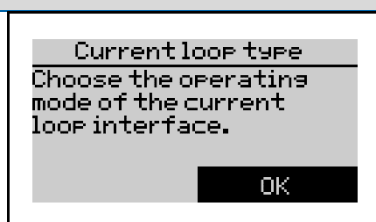

Press the [OK] key.

Power interfaces Type.

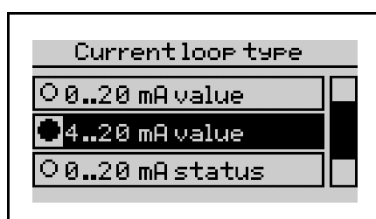

Use [▲] and [▼] to select the power interface type setting from the following options:

- From
- 0 to 20 mA value
- 4 to 20 mA value
- 0 to 20 mA Status
- 4 to 20 mA Status

Make your selection and confirm with the [OK] key.

(If Status is selected, see further information on page 39.)

Configuration

Calibrate current interface when value is selected

Enter the value that corresponds to 20 mA.

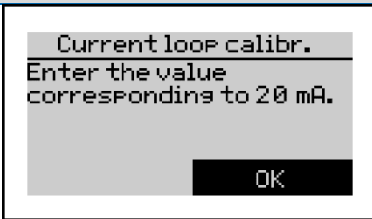

Press the [OK] key.

Calibrate current interface

Enter the value that corresponds to 20 mA.

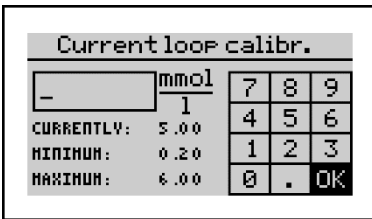

Here you can enter the measured value to which the current interface is to be scaled.

We recommend setting the value for 20 mA to the end of the reagent measuring range, but values below this can also be selected. For more information, see page 38.

You will see an input keyboard on the right. Now use the arrow keys [◀], [▶], [▲] and [▼] to move the black cursor to the desired digit and press the [OK] key.

The selected digit appears in a frame on the left.

Repeat the entry until the desired number appears in the frame.

Now move the cursor to the OK field on the keyboard and press the [OK] key.

You will see the following information on the left:

Current: currently programmed value

Minimum: smallest adjustable value

Maximum: largest adjustable value



If the value at "Current" corresponds to your wish, you do not need to enter the number again and can immediately move the cursor to the OK field in the keyboard and confirm with the [OK] key.

Wizard

The configuration is complete. The wizard is closed.



Press the [OK] key.

This completes the configuration of the unit.

If necessary, individual settings can also be made without the wizard.

Programming: Menu > Settings

Configuration

Menu structure

The following is an overview of the menu structure to give you an overview of all the functions of the analyser.

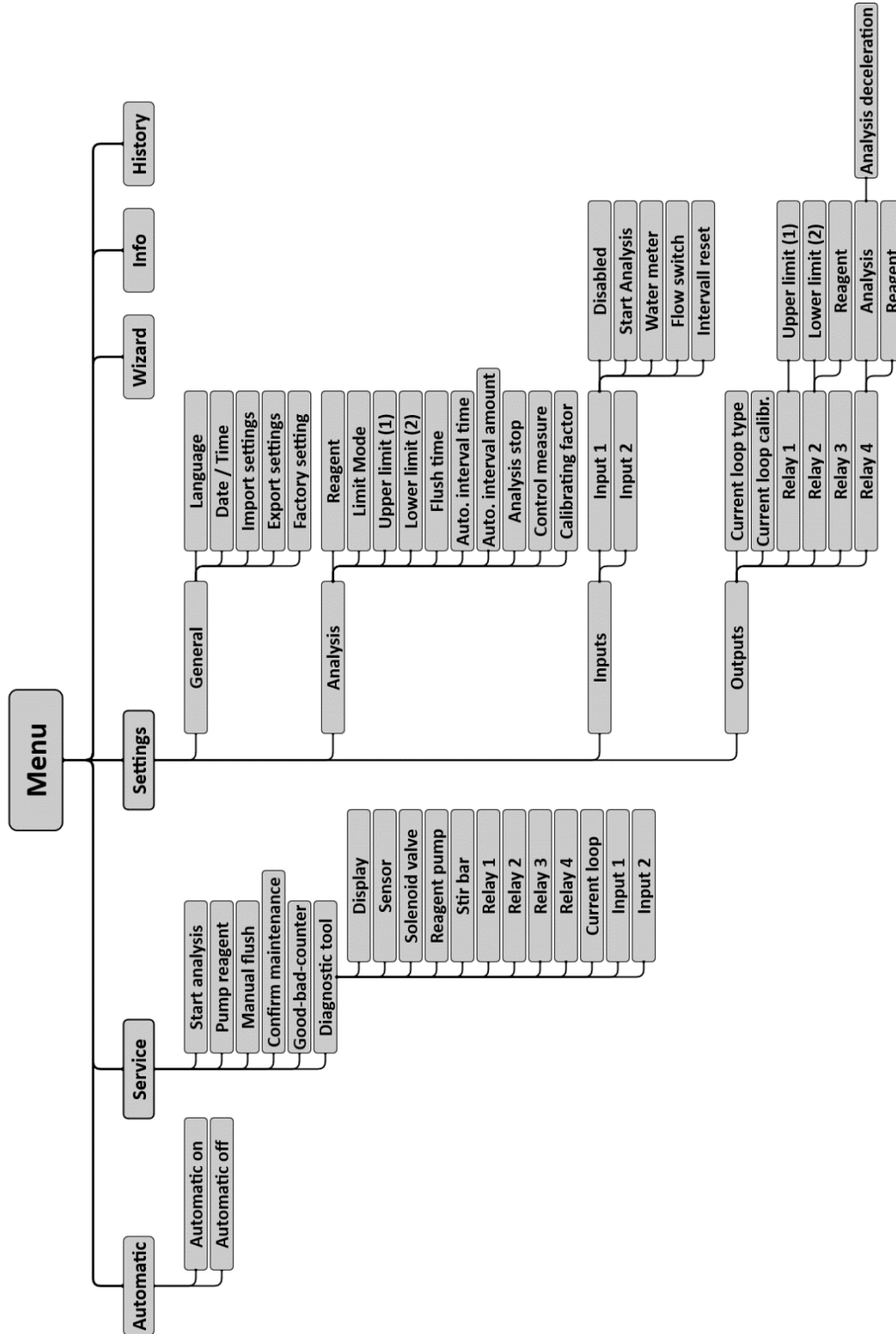

Illustration 31: Menu structure

Operation

Manual and automatic operation

The analyser can be started in automatic mode (Menu > Automatic) depending on the time or via an external button or flow monitor. In manual mode (Automatic Off), functions such as starting the analysis, pumping the reagent or rinsing can be controlled manually. In addition, manual mode also includes a diagnostic function to test individual unit components.

In automatic mode, analyses are carried out at the programmed interval or by external start. After switching on, the automatic mode is active. The first analysis is started after 3 minutes after switching on with programmed internal interval. All subsequent analyses are carried out at the programmed interval.

Main menu

The main menu can be opened by pressing the [Menu] key from the measured value view.



Illustration 32: Menu

| Menu item | Description |
|-----------|---|
| Automatic | Switch between automatic and manual mode |
| Settings | Setting the unit and analysis parameters |
| Info | Overview of hardware and software version and display of meter readings |
| Service | Functions for maintenance, diagnosis and reagent change |
| Wizard | Setup wizard for guided setup of the unit |
| History | Display of the last 100 measurement results with date and time |

Operation

Info display

The menu item Info in the main menu displays additional information about the unit and the measuring point:

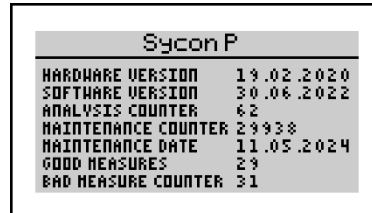

| Sycon P | |
|---------------------|------------|
| HARDWARE VERSION | 19.02.2020 |
| SOFTWARE VERSION | 30.06.2022 |
| ANALYSIS COUNTER | 62 |
| MAINTENANCE COUNTER | 29938 |
| MAINTENANCE DATE | 11.05.2024 |
| GOOD MEASURES | 29 |
| BAD MEASURE COUNTER | 31 |

Figure 33: Info

| Information | Description |
|---------------------|--|
| Hardware version | Version of the hardware used |
| Software version | Installed software version |
| Analysis counter | Number of analyses carried out since commissioning |
| Maintenance counter | Number of analyses remaining - life of the hose pump cassette: is set to 30,000 analyses when the maintenance is acknowledged in the service menu. |
| Maintenance date | Expiry date of the hose pump cassette used: is set to 2 years when the maintenance is acknowledged in the service menu. |
| Good counter | Number of analyses without exceeding the limit value: can be reset in the service menu under the item good/bad counter |
| Bad counter | Number of analyses with limit value exceeded: can be reset in the service menu under the item Good/Bad counter. |

Behaviour in the event of a power failure

All settings of the unit are stored on the SD card or in the internal memory. In the event of a power failure, all settings are available again even after the unit is switched on. If the unit has been in automatic mode, the analyser automatically restarts with an analysis according to the set interval times after a short dwell time.

Relay 2 (ready for operation/error) is energised after the unit is switched on (connection COM to NO). In this way, an external control can detect whether the unit is ready for operation or whether there is a fault such as a unit malfunction, power failure or line defect.

If there is a unit failure and it becomes necessary to replace the unit, you can export the settings from the old unit to the SD card inserted in the unit (Menu > Settings > General > Export settings). After inserting the SD card into the new device, the settings can be imported (Menu > Settings > General > Import settings). The measurement protocol on the SD card is continued by the new device.

Operation

SD card

The analyser contains an SD card. The following information is stored on this memory card: Measured values, error messages, unit configuration, unit firmware. The data is stored on the SD card as .csv files. These files can be opened with an editor or spreadsheet program (e.g. MS Excel, OO Calc) and the data can be processed further. Furthermore, system files (.bin) are available on the SD card.

The analyser is also fully functional without an SD card, but then only the last 100 measured values are stored internally.

If you wish to use an SD card other than the one supplied, make sure that it is formatted as follows:

FAT16 up to 4 GB

FAT32 up to 32 GB

The following files are stored on the card:

| File name | Type | Content |
|-------------|------------------|---|
| trend.csv | Data | Measured values in tabular form with date, time and measured value. The data are stored in the following format: YYYY.MM.DD [Tab] hh.mm [Tab] x.xxx [Tab] Unit [LF] The measured values (x.xxx) are stored in the unit displayed on the unit. |
| error.csv | Data | Error messages in tabular form with time, date and error. The data is stored in the following format: YYYY.MM.DD [Tab] hh.mm [Tab] Error code [LF]. |
| history.dat | System | Analysis results with time stamp The unit loads these into the internal memory at start-up. |
| setting.dat | System | Complete unit setting of the analyser (optional file) Before replacing the analyser, you can transfer the saved unit configuration directly to the new unit. The export is in the menu under Settings > General > Export. The transfer of the unit configuration is in the menu under: Settings > General > Import. |
| TP28xxx.bin | Operating system | This file is not available on the SD card by default. If there are software updates for your analyser, these will be provided to you by our sales partners or are available as a download on our homepage. You can copy this file to the SD card. Press and hold the [OK] button when you switch on the analyser. For more information on how to install a software update, see page 70. We recommend deleting the file from the SD card again after installing an update. |
| INDEX.HTM | Data | Unit configuration as HTML page. Can be printed out and saved for documentation of the unit. Generated when exporting the unit configuration. |
| MAIN.CSS | Data | Style file associated with INDEX.HTM for display as an A4 page. Is created when exporting the unit configuration. |

Maintenance and Service

To ensure long and trouble-free operation of the analyser, maintenance must be carried out on the unit at regular intervals. Make sure that the unit is switched off before maintenance work is carried out. No analyses are carried out during this time. As a general rule, wear protective goggles and gloves during maintenance to avoid contact with reagent, cleaning fluid or other liquids.

The following maintenance intervals must be observed:

| Interval | Maintenance and service |
|--|---|
| every 6 months | Cleaning the measuring chamber at high ambient and water temperatures or water with a high organic load, the cleaning intervals must be shortened if necessary. |
| every 30,000 analyses or after 24 months | Maintenance as after 6 months and Install maintenance set |

Cleaning the measuring chamber

Cleaning the measuring chamber takes about 20 minutes. To clean the measuring chamber, proceed as follows:

- Switch off the unit.
- Pull the hose pump cassette from the holder by unlocking it at the clips at the top and bottom.
- Disconnect the reagent plug and the reagent bottle.
- Pull the locking pins slightly forwards. (The locking pins can only be pulled up and not out).
- Pull the drain plug, actuator plug and inlet plug out of the measuring chamber.
- Pull the measuring chamber to the right off the retaining bolts on the control unit housing.
- Remove the stirring blade
- Lever the reagent plug upwards with a flat-blade screwdriver. (Make sure that the locking pins are pulled up before levering).
- Clean the measuring chamber and the plugs using the SYCON Clean cleaning set as described on the instruction leaflet.



For trouble-free operation, it is important to clean not only the measuring chamber but also the actuator plug with the white (LED). Take a cloth and moisten it with FIT3000 (included in the SYCON Clean Set) and wipe the actuator plug thoroughly.

When assembling, please be sure to observe the following sequence:

- Lubricate O-rings (3 x J and 1 x C) with technical Vaseline. See picture spare parts on Page 75.



The blue dosing O-ring (D) on the reagent plug must not be lubricated with technical Vaseline.

On the other hand, the black O-rings (3 x J and 1 x C) must be lubricated with technical Vaseline before insertion into the measuring chamber.

Maintenance and service

- Pull up the locking pins, insert the reagent plug and lock it.
- Place the cleaned measuring chamber on the retaining bolts and lock it in place.
- Insert the stirring blade into the measuring chamber.
- Pull up the locking pins Insert the inlet plug, actuator plug and drain plug into the measuring chamber and lock them.
(Make sure that all plugs are inserted into the measuring chamber as far as they will go and only then locked in place, otherwise the plugs may be damaged).
- Connect the peristaltic pump cassette to the reagent plug and to the reagent bottle.
- Place the hose pump cassette on the holder so that it clicks into place.
- Switch the unit on again.
- Rinse the measuring chamber (programming: Menu > Service > Manual rinsing).
- Pump reagent into the measuring chamber (programming: Menu > Service > Pump reagent).

Has a full reagent bottle been used?

Select [Yes] or [No] and press [OK].

[Yes] The bottle level is set to 100 %.

[No] The previous bottle fill level in % is retained.

- Rinse the measuring chamber again (programming: Menu > Service > Manual rinse).

The unit is ready for operation again.

Inserting the "Maintenance Set for SYCON P

The hose pump cassette, hoses and seals must be replaced at regular intervals.

The required replacement parts are included in the "Maintenance set for SYCON 2702/2802/P".
See page 77.

Maintenance takes about 25 min.

Proceed as follows:

- Switch off the unit.
- Pull the hose pump cassette from the holder by unlocking it at the clips at the top and bottom.
- Disconnect the reagent plug and the reagent bottle.
- Replace the bottle connector, suction lance and hose pump cassette.
- Pull the locking pins slightly forwards. (The locking pins can only be pulled up and not out).
- Pull the drain plug, actuator plug and inlet plug out of the measuring chamber.
- Pull the measuring chamber to the right off the retaining bolts on the control unit housing.
- Remove the stirring blade
- Lever the reagent plug upwards using a flat-blade screwdriver. (When levering out, make sure that the locking pins are pulled up).

Maintenance and service

- Pull up the locking pin at light stick stopper.
- Take a non-metallic object such as a plastic or wooden rod, insert it into the actuator plug hole and use it to push out the light rod plug.
(The light rod plug belongs to the optical measuring section and must not be scratched).
- Remove the O-rings (4 x J, 1 x C and 1 x D) from the plugs. See the spare parts picture on page 75.
- Clean the measuring chamber and the plugs using the SYCON Clean cleaning set as described on the instruction leaflet.



For trouble-free operation, it is important to clean not only the measuring chamber but also the actuator plug with the white (LED). Take a cloth and moisten it with FIT3000 (included in the SYCON Clean Set) and wipe the actuator plug thoroughly.

When assembling, please be sure to observe the following sequence:

- Push the O-rings onto the plugs (4 x J, 1 x C and 1 x D). 75.

The blue dosing O-ring (D) on the reagent plug must not be lubricated with technical Vaseline.



On the other hand, the black O-rings (4 x J and 1 x C) must be lubricated with technical Vaseline before insertion into the measuring chamber.

- Pull up the locking pin, insert the light rod plug and lock it.
- Pull up the locking pins, insert the reagent plug and lock it.
- Place the cleaned measuring chamber on the retaining bolts and lock it in place.
- Insert the stirring blade into the measuring chamber.
- Pull up the locking pins Insert the inlet plug, actuator plug and drain plug into the measuring chamber and lock them.
(Make sure that all plugs are inserted into the measuring chamber as far as they will go and only then locked in place, otherwise the plugs may be damaged).
- Connect the peristaltic pump cassette to the reagent plug and to the reagent bottle.
- Place the hose pump cassette on the holder so that it clicks into place.
- Switch the unit on again.
- Rinse the measuring chamber (programming: Menu > Service > Manual rinsing).
- Pump reagent into the measuring chamber (programming: Menu > Service > Pump reagent).

Has a full reagent bottle been used?

Select [Yes] or [No] and press [OK].

[Yes] The bottle level is set to 100 %.

[No] The previous bottle fill level in % is retained.

- Rinse the measuring chamber again (programming: Menu > Service > Manual rinse).
- Reset the maintenance counter to 24 months / 30,000 analyses
(Programming: Menu > Service > Acknowledge Maintenance).

The unit is ready for operation again.

Maintenance and service

Reset maintenance counter

After maintenance has been carried out with the "Maintenance set for SYCON 2702" inserted, the maintenance counter in the SYCON must be reset.

The message "Maintenance" disappears from the display and only appears after 24 months or after 30,000 analyses, in which case maintenance must be carried out again.

(Programming: Menu > Service > Acknowledge Maintenance).



Figure 34: Maintenance counter

Select [Yes] or [No] with [◀] and [▶] confirm with [OK].

[Yes] Maintenance counter is set to 30,000 analyses and the maintenance date is set to 24 months. (To be read in the menu > Info)

[No] The unit retains the previous data.

Changing the reagent bottle

First check the expiry date of the new reagent bottle. Only use reagent whose shelf life has not yet expired.



Always use reagent bottles with a capacity of 500 ml.

Proceed as follows:

- Switch off the unit.
- To change the reagent bottle, loosen the screw cap on the bottle and insert the new reagent bottle. Take up any drips if necessary.
- Switch the unit on again.
- Rinse the measuring chamber (programming: Menu > Service > Manual rinsing).
- Pump reagent into the measuring chamber (programming: Menu > Service > Pump reagent) until reagent enters the measuring chamber without bubbles. Then press the [OK] button to finish bleeding the reagent line.

Has a full reagent bottle been used?

Select [Yes] or [No] and press [OK].

[Yes] The bottle level is set to 100 %.

[No] The previous bottle fill level in % is retained.

- Rinse the measuring chamber again (programming: Menu > Service > Manual rinse) to clean the measuring chamber.
- Test the analysis procedure by starting an analysis. To do this, press and hold the [OK] button for 3 seconds in the measured value view.

The unit is ready for operation again.

Maintenance and service

Good and bad counters

The good and bad counters are used to count the analysis results. They are displayed in the info screen.

Programming: Menu > Info

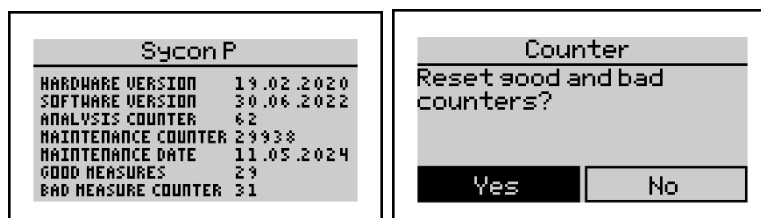

Figure 35: Good and bad counter

Exceeding the limit value increases the bad meter, and falling below the limit value increases the good meter. This counter can be used to assess the function of a softening system. The number of bad measurements should be significantly smaller than the number of good measurements. The counters can be reset in the menu.

Programming: Menu > Service > Good/Bad counter

Calibrating the unit

The unit is calibrated at the factory at a room temperature of 20 °C. When operating in very warm or cold locations, we recommend calibrating the unit during commissioning.

To calibrate the unit, proceed as follows:

- Carry out an analysis with the device. The p-value of the sample must be within the measuring range of the reagent used. A measured value such as < 0.2 mmol/l cannot be used.
- Analyse the water in the laboratory in parallel.
- Calculate the correction factor for the analyser using the following formula:

$$\text{Korrekturfaktor} = \frac{\text{Messwert}_{\text{Labor}}}{\text{Anzeigewert}} \cdot 100 \%$$

- Set the correction factor in the unit under the specified path.
(Programming: Menu > Settings > Analysis > Calibration factor)

Example calculation:

Measured value_{Labor} = 2 mmol/l

Display value from the SYCON display = 1.8 mmol/l

$$\text{Korrekturfaktor} = \frac{2 \text{ mmol/l}}{1,8 \text{ mmol/l}} \cdot 100 \%$$
$$\text{Korrekturfaktor} = 111,1 \%$$

111.1 % rounded => correction factor = 111 %

The entry is only made with whole numbers, therefore round down/up and enter the correction factor in the input mask on the unit.

Maintenance and service

Change battery

If the unit does not display the time after it has been switched off and on again, the internal backup battery must be replaced. The battery used at the factory has a service life of several years. The clock is powered by the mains adapter when it is switched on. Therefore, the battery life is longer if the unit is not switched off.

Proceed as follows:

- Switch off the unit and disconnect the power supply.
- Open the control unit housing with the 4 screws. On the inside you will see the battery holder.
- Replace the battery with a new one of type CR2032.
- Close the control unit again. Make sure that the connection cable between the display board and the control unit has not come loose.
- Dispose of the battery at a collection point for batteries.

Software update

The analyser offers the possibility of a software update. As part of the product improvement, you will receive software updates via your dealer or via our website. Should this be necessary, your dealer will send you a file with the name TP28xxx.bin.

To perform a software update, proceed as follows:

- Switch off the unit and disconnect the power supply.
- Open the control unit housing with the 4 screws and remove the SD card.
- Copy the file TP28xxx.bin to the SD card with the help of a computer and insert it again.
- Close the control unit again. Make sure that the connecting cable between the display board and the control unit has not come loose.
- Press and hold the [OK] key and switch on the unit. As soon as Software Update appears in the display, release the [OK] key. The machine updates the software.
- Switch off the unit, remove the SD card and delete the file TP28xxx.bin from the SD card.
- Insert the SD card back into the unit.
- Check the unit configuration of the unit.

Diagnostic functions

Pay attention to any connected controls and peripherals.
Observe the valid safety regulations.

To do this, call up the following programme function:
Programming: Menu > Service > Diagnostic programme

Display

The display changes colour between red, green and blue.
Press the [OK] key to exit.

Sensor

The LED in the measuring chamber is switched on and off. In case of a defective colour sensor, an error message appears. If the LED in the measuring chamber does not light up, check the electrical connection of the LED at the actuator plug and in the unit. If the plugs are seated properly, the actuator must be replaced. During the test, intensity bars for red, green and blue are displayed. Press the [OK] key to finish.

The positioning of the connectors can be found on page 18 page.

Solenoid valve

The solenoid valve in the water inlet can be opened and closed via the [OK] button. If this is not the case, please check the electrical connection of the solenoid valve in the unit. If the plugs are seated correctly, measure the voltage between the connections on the valve when the valve is "open". This should be 24 VDC. If this is the case, a fault in the electronics can be ruled out and the solenoid valve is defective.

To exit, move the cursor to Exit and press the [OK] key.

The positioning of the connectors can be found on page 18 page.



If a sample cooler is used, the proper operation of the sample cooler must be checked in advance to exclude any risk from hot steam or hot water.

Reagent pump

When the reagent pump is started, the peristaltic pump cassette is driven for 2 seconds. The rotation of the rollers in the peristaltic pump cassette is visible and the rotation of the motor can be heard. If this is not the case, check the four-pole connection of the motor on the circuit board. If only the noise is perceptible, the hose pump cassette is defective. In the other case, a fault of the motor or the control board is possible.

To exit, move the cursor to Exit and press the [OK] key.

The positioning of the connectors can be found on page 18 page.

Diagnostic functions

Stir wings

The stirring blade in the measuring chamber is activated and slowly increases its speed to the maximum. If the stirring blade does not rotate, check that the plug connector of the drive motor is correctly seated on the control board (red plug connector).

Remove the measuring chamber and check that the drive pulley (this has two silver magnets) in the agitator is not rubbing or resting against the motor housing.

If none of these causes can be determined, the drive motor must be replaced.

Press the [OK] key to exit.

The positioning of the connectors can be found on page 18 page.

Relay 1 to 4

When starting the diagnostic function Relay, the selected relay is switched between the two contacts NC and NO via the [OK] key.

Use a continuity tester to check the contact between the connections COM and NC and COM and NO. If the switching operations cannot be measured, replace the control board. To exit, move the cursor to Exit and press the [OK] key.

The positioning of the relays can be found from page 22.

Power interface

A current meter is required to test the current interface. Measurements are taken between terminals 11 (+) and 12 (-).

The current output is shown in the display as $I = xx \text{ mA}$. The same value should also be measured at the two terminals. Tolerance $\pm 0.3 \text{ mA}$. Please observe the accuracy of your current measuring device.

Pressing the [OK] key increases the output current by 2 mA each until the maximum value of 20 mA is reached.

To exit, move the cursor to Exit and press the [OK] key.

Input 1 and 2

To test the inputs, you need a conductor or a multimeter set to continuity test.

If no jumper is set between terminal 13 (28) and 14 (29), the display shows "open".

If a jumper is set between terminal 13 (28) and 14 (29), the display shows "closed".

(If you want to establish the bridge with a multimeter, the COM connection of the multimeter must be connected to terminal 13 (28) and the volt connection of the multimeter to terminal 14 (29). Otherwise, no bridge will be established by the multimeter).

Press the [OK] key to exit.

The positioning of the inputs can be found on the page 27 page.

The diagnostic mode is finished.

Error messages

Analysis does not start

- Check whether a flow monitor is configured and connected.
- Check whether an interval time has been entered.
- Check that a water meter is fully configured and connected.
- If necessary, check the connection from an external control to the unit.

Error message E11 reagent

After the first dosing of the analysis, no sufficient discolouration was detected in the sample.

- Check whether there is still enough reagent in the reagent bottle.
- Check the connecting tube between the reagent bottle and the peristaltic pump for air bubbles. If necessary, pump reagent until the hose is completely filled with reagent.
- Check whether there is water in the measuring chamber.
- Check the dosing pump and agitator assemblies.
- Check that the water drain is clear and that no foreign bodies have become lodged in the solenoid valve.
- When using a pump for sample delivery, check that the pump is connected correctly.
- Check that the inlet and outlet are connected the right way round.
- Check that the stirring blade is in the measuring chamber.
- 0mA is output at the current output if the type "value" is set at the current interface.

Error message E12 Water flow

The measuring chamber is not rinsed with clear water after the end of the analysis. The sensor does not detect any lightening of the measuring chamber due to rinsing.

- Check whether there is line pressure at the unit connection.
- Check the function of the solenoid valve.
- Check if the drain is clogged.
- If necessary, check the function of the sample pump, stopcocks and valves.
- 0mA is output at the current output if the type "value" is set at the current interface.

Error message E13 Optics

No difference in brightness was detected after switching on the actuator LED.

- Check the measuring chamber for dirt.
- Check the electrical connection of the actuator plug.
- Check the correct position of the actuator plug.
- Check the colour sensor in the diagnostic menu.
- 0mA is output at the current output if the type "value" is set at the current interface.

Error messages

Error message E14 Titration

During titration, the colour change in the measuring chamber is too weak. Too little reagent is dosed.

- Check whether there is still enough reagent in the reagent bottle.
- Check the connecting tube between the reagent bottle and the peristaltic pump for air bubbles. If necessary, pump reagent until the hose is completely filled with reagent.
- Check that the inlet and outlet are connected the right way round.
- Check that the programmed reagent type matches the one used.
- Check that the water drain is clear and that no foreign bodies have become lodged in the solenoid valve.
- Check the function of the dosing pump.
- Check the dosing plug and reagent tubes for foreign objects.
- Check that the blue O-ring on the dosing plug is present and properly seated.
- 0mA is output at the current output if the type "value" is set at the current interface.

Appendix

Spare parts

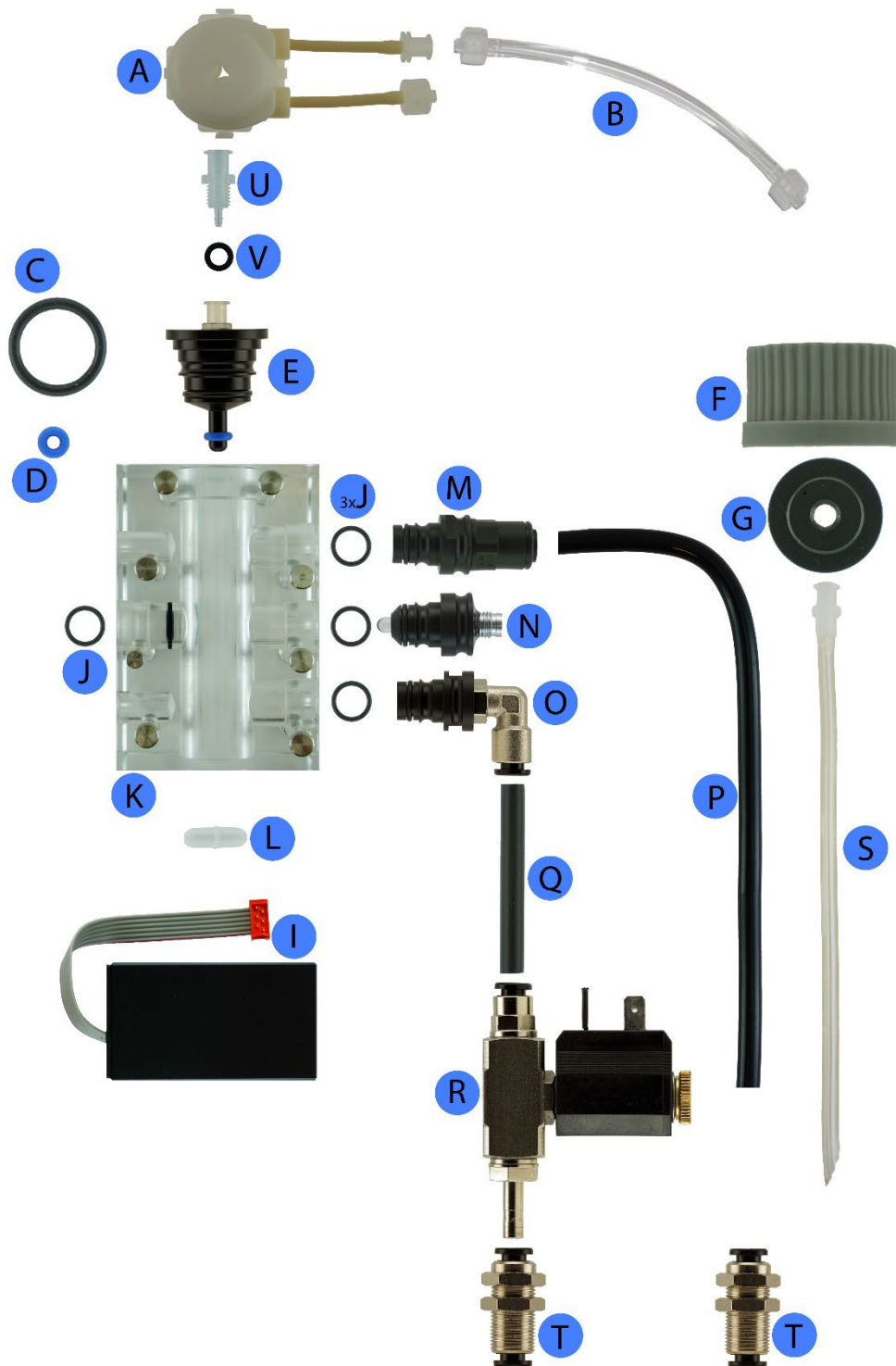

Appendix

| Position | Article description | Article number |
|----------|---|----------------|
| A | Hose pump cassette complete | 33-030 614 |
| B | Bottle connector | 33-090 008 |
| C | O-ring 16 x 2 | 33-090 217 |
| D | Dosing O-ring 3.2 x 2.5 blue | 33-090 218 |
| E | Reagent plugs incl. position U, V, C, D | 33-090 716 |
| F | Bottle cap | 33-093 060 |
| G | SYCON bottle adapter | 33-090 009 |
| I | Agitator | 33-090 056 |
| J | O-ring 9 x 1.5 | 33-090 210 |
| K | Measuring chamber pre-assembled | 33-090 731 |
| L | Stirrer blade | 33-090 002 |
| M | Drain plug 6 mm incl. O-ring | 33-090 712 |
| N | Actuator plug (LED) incl. O-ring | 33-090 713 |
| O | Inlet plug with angle connection incl. O-ring | 33-090 156 |
| P | Drain hose 200 mm long \varnothing 6 x 4 mm | 33-090 124 |
| Q | Supply hose 50 mm long \varnothing 6 x 4 mm | 33-090 112 |
| R | Solenoid valve SYCON 24 V | 33-090 157 |
| S | Suction lance | 33-090 011 |
| T | Bulkhead connector straight | 33-090 116 |
| V | O-ring 5.28 x 1.78 | 33-090 215 |
| U | Luer connection | 33-090 414 |

Spare parts without illustration

| Article description | Article number |
|---|----------------|
| Measuring chamber incl. position E, M, N, O, L | 33-190 700 |
| Display board | 33-033 607 |
| Main board SYCON P 230 VAC | 33-040 649 |
| Main board SYCON P 24 V AC/DC | 33-040 657 |
| Hose pump cassette complete with motor, SYCON 2702/2802/P | 33-030 625 |
| Connecting cable solenoid valve SYCON series | 33-090 079 |
| Connecting cable actuator | 33-090 074 |
| Maintenance set SYCON 2702/2802/P incl. position A, B, C, D, S, 4 x J, L | 33-090 034 |
| Cleaning set SYCON CLEAN (Please read the contents of the set in the chapter Spare parts > Maintenance sets) | 30-010 900 |
| FIT 3000 cleaner (1000 ml) for cleaning the measuring chamber | 32-089 100 |



Appendix

Maintenance sets

The SYCON P operates largely maintenance-free. A maintenance set is available for the analyser. It is recommended to change the hose pump cassette, hoses and O-rings after 30,000 analyses or 24 months. The unit shows a maintenance note in the display after the maintenance interval has expired. The maintenance counter must be reset or acknowledged after maintenance has been carried out.

Furthermore, it is recommended to clean the measuring chamber regularly, at least every 6 months. The SYCON Clean cleaning set is offered for this purpose. It contains all the tools needed for cleaning as well as the cleaning fluid FIT 3000.

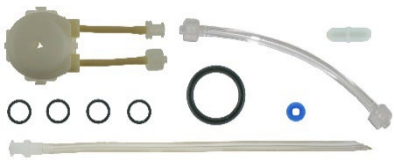
For information on carrying out maintenance, see the chapter "Maintenance and service".
from page 65.

| Article description | Article number |
|---|--|
| Maintenance set for SYCON 2702/2802/P | 33-090 034 |
| Contains the following items: <ul style="list-style-type: none">• 1 x 33-090 008 Bottle connector• 1 x 33-090 011 Suction lance• 1 x 33-090 217 O-ring 16x2• 4 x 33-090 210 O-ring 9x1.5• 1 x 33-090 218 O-ring blue• 1 x 33-030 614 Hose pump cassette• 1 x 33-090 002 Stirrer blade |  |
| Cleaning set SYCON Clean | 30-010 900 |
| Cleaning set for measuring chambers, contains the following items: <ul style="list-style-type: none">• 10 pairs of gloves XL• 1 x PP funnel• 1 x FIT 3000 cleaner (1000 ml)• 1 x pipette brush• 1 x test tube brush• 1 x container with lid |  |
| Measuring chamber cleaner FIT 3000 (1000 ml) | 32-089 100 |

Appendix

Accessories

| Article description | Article number |
|--|----------------|
| Pressure regulator with wall bracket | 33-090 738 |
| Contains the following items: | |
| <ul style="list-style-type: none">• Pressure regulator with wall bracket• 2 x hose connector, external diameter 6 mm | |
| Technical data: | |
| <ul style="list-style-type: none">• Max. inlet pressure 13 bar• Control range 0 to 4 bar• With pressure gauge and filter (>20 µm) | |
| Connection set SYCON | 33-000 701 |



| | |
|---|--|
| Contains the following items: | |
| <ul style="list-style-type: none">• Reducing nipple Stainless steel 1.4408 V4A 1/2 inch to 1/4 inch (conical male thread)• Socket ball valve stainless steel 1.4408 V4A with 1/4 inch (cylindrical internal thread)• Straight screw-in fitting, nickel-plated brass. 1/4 inch (cylindrical external thread with sealing ring), hose connection external diameter 6 mm.• 5 metre plastic hose outer diameter 6 mm | |
| + 5 metre plastic hose outer diameter 6 mm | |



Sample cooler

The maximum inlet temperature of the sample water is 40°C. If the sample water has a higher temperature, an upstream cooler must be used. Depending on the temperature of the water and the cooling water, upstream coolers are offered for flow-through cooling.

Further information and data sheets can be found on our website.

Appendix

Settings:

| | |
|----------------------------|---------------|
| Language | |
| <input type="checkbox"/> | German |
| <input type="checkbox"/> | English |
| <input type="checkbox"/> | French |
| <input type="checkbox"/> | Italian |
| <input type="checkbox"/> | Spanish |
| <input type="checkbox"/> | Russian |
| <input type="checkbox"/> | Polish |
| <input type="checkbox"/> | Dutch |
| <input type="checkbox"/> | Danish |
| Reagent | |
| <input type="checkbox"/> | P25-5 |
| <input type="checkbox"/> | P25-20 |
| Flushing time: | s |
| Limit mode | |
| <input type="checkbox"/> | Max/Min |
| <input type="checkbox"/> | Max/Max |
| Limit values | |
| Limit value 1: | mmol/l |
| Limit value 2 : | mmol/l |
| Time interval | |
| <input type="checkbox"/> | No min |
| <input type="checkbox"/> | Yes |
| Quantity interval | |
| <input type="checkbox"/> | Yes: ln |
| <input type="checkbox"/> | No |
| Control measurement | |
| <input type="checkbox"/> | No repetition |
| <input type="checkbox"/> | 1 Repetition |
| <input type="checkbox"/> | 2 repetitions |
| <input type="checkbox"/> | 3 repetitions |
| Analysis stop | |
| <input type="checkbox"/> | Yes |
| <input type="checkbox"/> | No |

| | |
|--------------------------|-------------------|
| Entrance 1 | |
| <input type="checkbox"/> | Deactivated |
| <input type="checkbox"/> | Start analysis |
| <input type="checkbox"/> | Water meter |
| ↳ litres/imp: | l/imp |
| ↳ Contact type | |
| <input type="checkbox"/> | Hall |
| <input type="checkbox"/> | Reed |
| ↳ Unit | |
| <input type="checkbox"/> | l |
| <input type="checkbox"/> | hl |
| <input type="checkbox"/> | m ³ |
| <input type="checkbox"/> | gal(US) |
| <input type="checkbox"/> | gal(GB) |
| ↳ Flow monitor | |
| <input type="checkbox"/> | NC |
| <input type="checkbox"/> | NO |
| ↳ Interval reset | |
| <input type="checkbox"/> | NC |
| <input type="checkbox"/> | NO |
| Relay 1 | |
| <input type="checkbox"/> | Permanent contact |
| <input type="checkbox"/> | Pulse contact: s |
| Relay 2 | |
| <input type="checkbox"/> | Reagent shortage |
| <input type="checkbox"/> | Limit value 2 |
| <input type="checkbox"/> | Permanent contact |
| <input type="checkbox"/> | Pulse contact: s |
| Relay 4 | |
| <input type="checkbox"/> | Reagent shortage |
| <input type="checkbox"/> | Analysis active |
| <input type="checkbox"/> | Analysis delay: s |
| Power interface | |
| <input type="checkbox"/> | Deactivated |
| <input type="checkbox"/> | 0..20mA Status |
| <input type="checkbox"/> | 4..20mA status |
| ↳ 20mA: | mmol/l |
| <input type="checkbox"/> | 0..20mA value |
| <input type="checkbox"/> | 4..20mA value |
| ↳ 20mA: | mmol/l |

Appendix

Document changes:

| Date: | Change: |
|------------|--|
| 05.07.2022 | Publication of the document |
| 07.07.2022 | Shelf life of the reagent adjusted to 1 year renamed indicator to reagent |
| 05.12.2024 | New pressure regulator added to accessories |
| | |
| | |
| | |

Declaration of conformity



EG-KONFORMITÄTSERKLÄRUNG

EC-Declaration of Conformity

| | | |
|---|--|---|
| Hersteller <i>Manufacturer</i> | RLS Wacon analytics GmbH | |
| Anschrift <i>Address</i> | Gropiusstr. 12 D-31137 Hildesheim | |
| Produktbezeichnung <i>Product specification</i> | SYCON P | |
| Wir erklären in alleiniger Verantwortung, dass das oben bezeichnete Produkt mit folgenden Europäischen Richtlinien übereinstimmt: <i>We declare that the above product is in conformity with the following directives:</i> | 2014/35/EU | Niederspannungsrichtlinie <i>Low Voltage Directive</i> |
| Angewandte harmonisierte Normen und technische Spezifikationen: <i>Applied harmonised standards and technical specifications:</i> | DIN EN 61000-3-2 DIN EN 61000-3-3 DIN EN 61000-3-4 DIN EN 61326-1 | |
| Qualitätssicherung der Produktion: <i>Production Quality Assessment:</i> | DIN EN ISO 9001:2015 | |

Hildesheim, 16.04.2021
*Ort, Datum der Ausstellung
Place, date of issue*

Dr. Sascha Matern

*Name des Befugten /
Dokumentenbevollmächtigter
Name of authorized person /
Document manager*

Imprint:

© RLS Wacon analytics GmbH
Gropiusstr. 12
D - 31137 Hildesheim

Phone: +49 (0) 5121 / 28126-0
Fax: +49 (0) 5121 / 28126-20

info@rls-wacon.de
www.rls-wacon.de

Managing Directors: Dr Claudia Rudolph, Dr Sascha Matern
Register court: Hildesheim Local Court
Registration number: HRB 203 391
VAT ID: DE240123142

Photo back: Vitali Vidnevski (employee RLS Wacon analytics GmbH), 2015
Changes and errors excepted

07.07.2022

Sicherheit zuverlässig produziert.

