

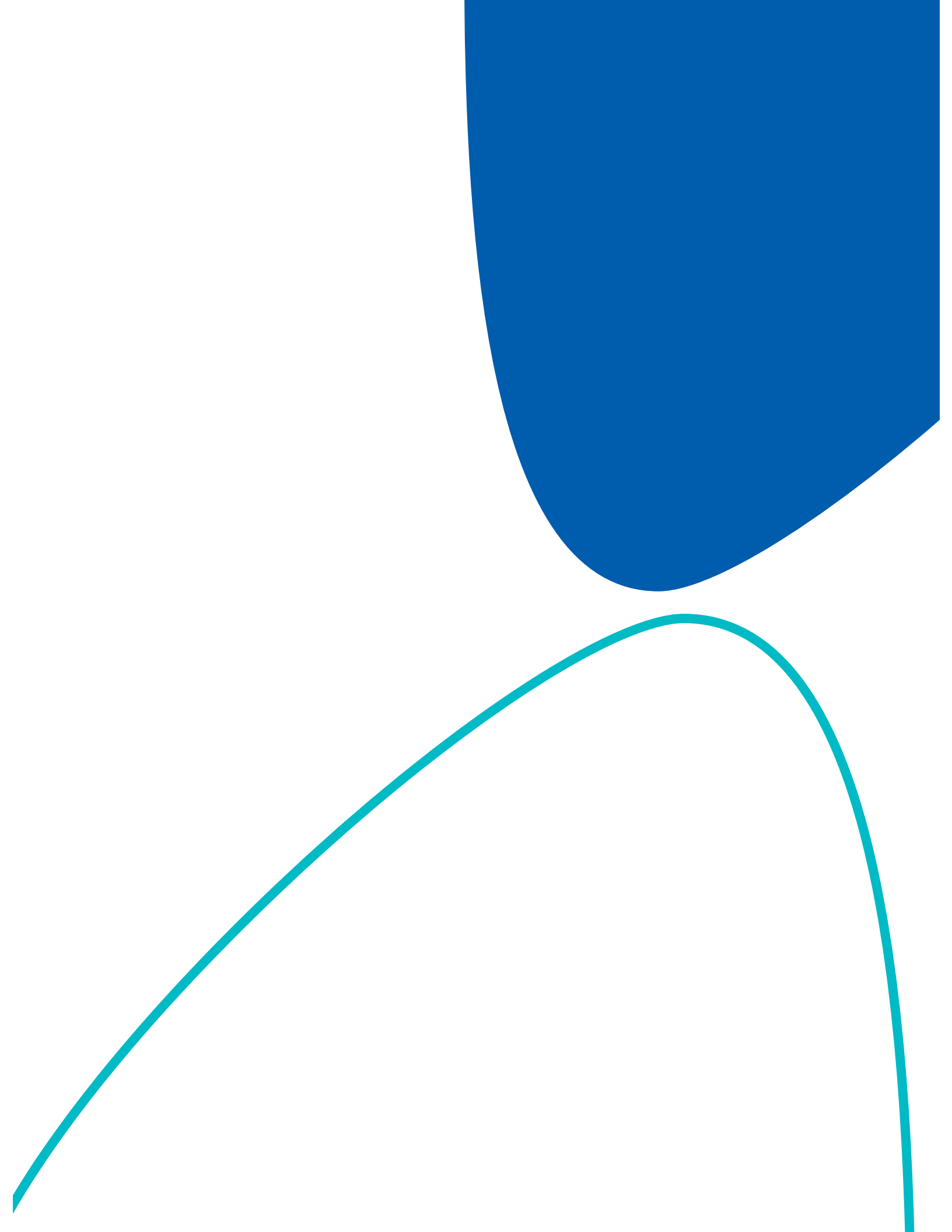

PERISTALTIC PUMPS

www.acmepompe.it





INDEX

ACME

Our company

4

General information

Operation, Features and Benefits, Applications,
Tube Types Table, Composition Table

7

Peristaltic pumps AS

AS FX, AS VX, AS IX, AS Technical Features

13

Peristaltic pumps ASP

ASP FX, ASP VX, ASP IX, ASP Technical Features

20

Peristaltic pumps ATR

ATR FX, ATR IX, ATR Technical Features

30

ACME – CLEVER PUMPS INNOVATIVE SOLUTIONS FOR FLUID TRANSFER AND DOSING SINCE 1992

Founded in 1992, ACME Pumps quickly established itself as one of the leading manufacturers of industrial peristaltic pumps, air-operated double diaphragm pumps, centrifugal pumps and diaphragm metering pumps. With decades of experience supporting businesses across various sectors, our mission is to deliver highly specialized, tailor-made pumping solutions, solving complex challenges and meeting the unique needs of every customer.

Headquarters and Production Facility

ACME's headquarters and manufacturing facility are located in Santo Stefano Ticino, just 25 km west of Milan and 30 km south of Malpensa Airport (MXP). This strategic location allows us to efficiently serve both national and international clients, offering excellent logistical connections for shipments and customer support. Our facility houses both the production plant and the commercial offices, enabling close coordination between our technical and sales teams to ensure fast, customized service.

A Dynamic, Customer-Focused Company

ACME is a lean and flexible organization, able to adapt swiftly to market demands. Our customer-centric approach is reflected in our unique ability to respond to specific and customized requests. Thanks to our strong design expertise and long-standing partnerships with trusted suppliers, we can handle demand surges and provide prompt, reliable solutions—even through well-established subcontracting agreements.

High-Quality Products for Every Industrial Sector

ACME offers a wide range of PERISTALTIC pumps, ideal for dosing and transferring fluids in a variety of industrial applications. Sizes range from DN10 to DN80, with flow rates between 1 and 66,000 L/h. The pumps can be supplied with fixed speed or variable speed, adjustable by means of a mechanical variator or a variable frequency drive. Thanks to FDA and ATEX certifications, our pumps are fully qualified to operate in the food and pharmaceutical industries, as well as in any environments classified as potentially explosive.

ACME pumps are used across a wide range of industries, including:

- Water purification, wastewater treatment, aquariums, marine and naval sectors
- Chemical, pharmaceutical, and cosmetics industries
- Winemaking, food, and dairy sectors
- Paints, inks, paper mills, and tanneries
- Construction, cement and ceramic plants
- Gas scrubbing towers.

Thanks to their durability and versatility, our pumps are ideal for transferring and dosing challenging fluids such as corrosive, abrasive, viscous liquids, or those with solid suspensions. They are designed to handle intermittent flow, difficult suction conditions, and can run dry for extended periods.

Our Mission and Commitment to Quality

Our mission is clear: to deliver specific, customized pumping solutions with the customer always at the center. To ensure maximum reliability, we are constantly improving our products and manufacturing processes. Quality is our hallmark, achieved through:

- Long-standing collaborations with trusted suppliers





- Careful selection of materials and components
- Strict control over the entire production process
- Specialized expertise within our team

A Leading International Brand

Driven by the professionalism and passion of our team, ACME has grown steadily over the years, strengthening its presence both in the local and international markets. Today, we are recognized as one of the key players in the pump sector, and we continue to expand our reach to meet the needs of an increasingly demanding market.

Our Product Range

Our range of pumps includes:

- **Peristaltic pumps** – ideal for dosing and transferring viscous fluids with solid particles
- **Double diaphragm pneumatic pumps** – suitable for aggressive industrial fluids
- **Diaphragm dosing pumps** – designed for applications requiring precise dosing

- **Mag-drive and mechanically sealed centrifugal pumps** – for pulse-free transfer of low-viscosity fluids
- **Drum and IBC transfer pumps** – designed for direct liquid transfer from drums or IBC tanks

Core Values

At the heart of our corporate philosophy lies the customer and a strong commitment to compliance and ethical standards. Every member of our internal and external teams is dedicated to providing solutions that are competent, reliable, and timely.

Conclusion

For over 30 years, ACME Clever Pumps has stood for quality, innovation, and reliability in the industrial pump industry. Backed by decades of experience and a drive for continuous innovation, we are ready to support every customer—facing today's challenges and shaping tomorrow's solutions together.



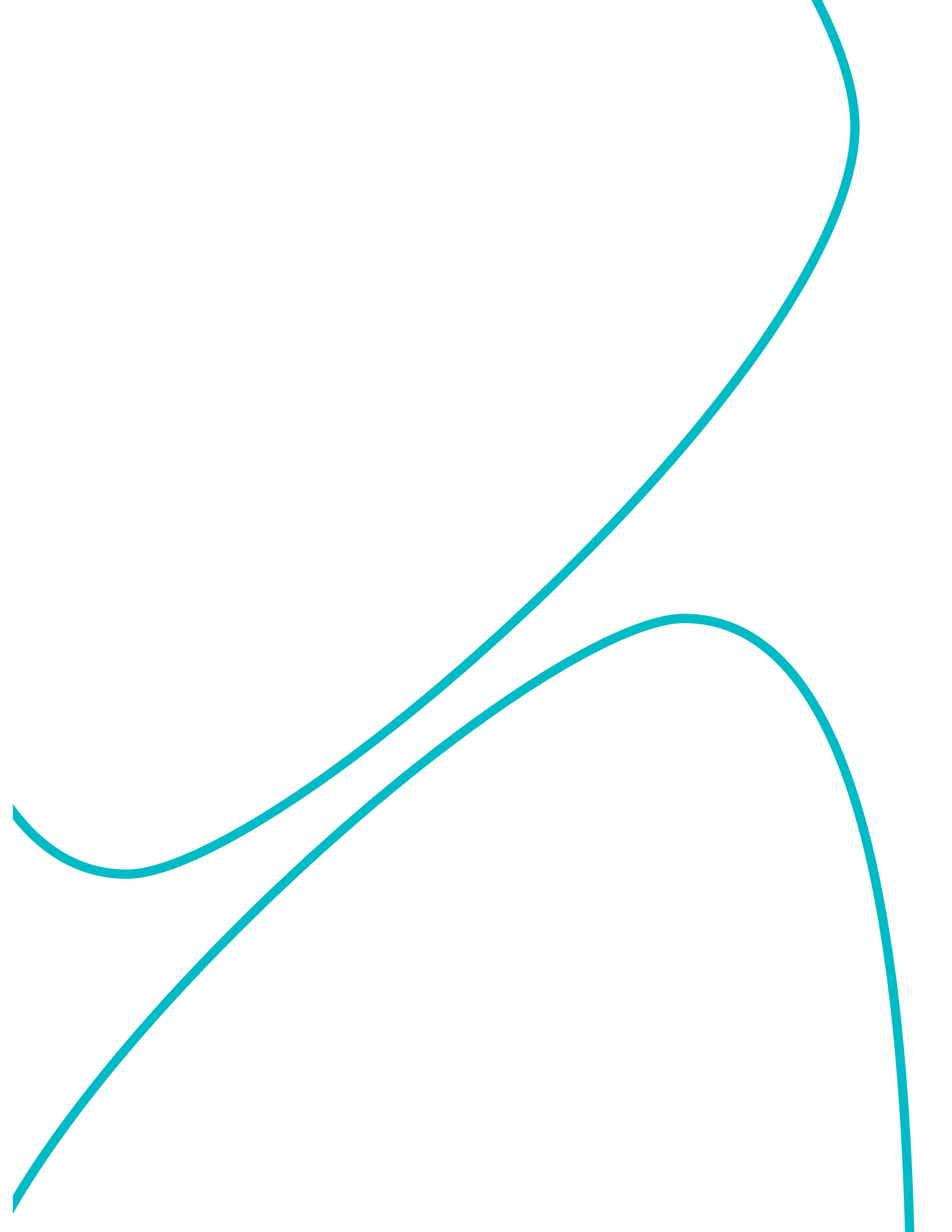

GENERAL INFORMATION



PUMP OPERATION

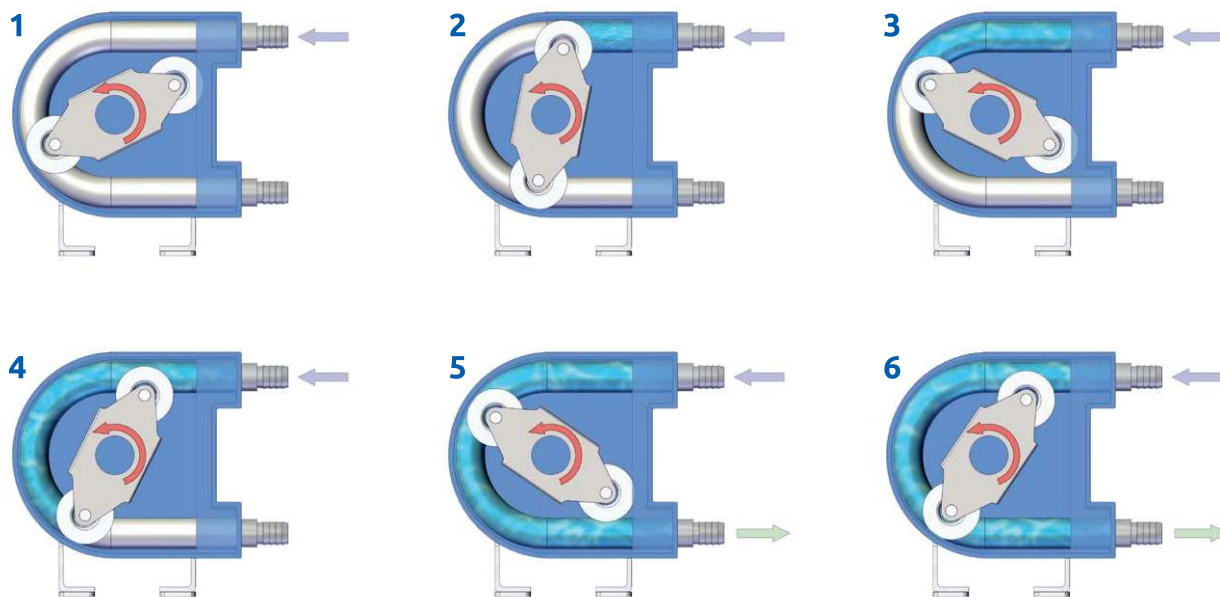

The peristaltic pump is a self-priming volumetric unit, ideal for the dosing and transfer of abrasive fluids, viscous liquids, or those containing solid particles. The principle is based on the progressive compression of a flexible hose by rollers or shoes mounted on a rotor. The rotary motion sequentially compresses the hose, creating suction and discharge zones that ensure a continuous flow. The hose, equipped with elastic memory, quickly returns to its original shape after compression, promoting fluid suction and ensuring a perfect seal. The fluid is confined inside the hose, preventing contamination and making the pump suitable even for aggressive or sensitive fluids.

FEATURES & BENEFITS

Seal-less design

No mechanical seals, stuffing boxes, or other rotating sealing components are present in contact with the fluid, eliminating leakage risks.

Accurate and repeatable dosing

The pumps ensure accuracy up to $\pm 0.5\%$ over the entire speed range, with excellent repeatability and easy integration into process control systems.

Lowest cost of ownership and easy maintenance

The pumped fluid is contained exclusively within the hose, which is the only wear component. Hose replacement is quick and simple, resulting in significantly lower maintenance costs compared to other pump technologies.

Long service life and high reliability

The pumps are designed for heavy-duty industrial applications. Advanced elastomer technology ensures reliable, consistent performance that outperforms conventional pump solutions.

Reversible flow

Bidirectional operation allows easy emptying and draining of pipelines.

Self-priming and dry-run capability

Pumps can self-prime up to 9.8 meters and can run dry continuously without damage.

Low noise level

Sound level below 70 dB(A) at 1 meter.

High viscosity capability

ACME peristaltic pumps can transfer fluids with viscosities up to 50,000 cP, and can handle up to 100,000 cP when dealing with non-Newtonian fluids.

Certifications

ATEX and FDA certifications are available, making this technology suitable for applications in the food, pharmaceutical, chemical, and petrochemical industries.

APPLICATIONS

Abrasive Products

ACME peristaltic pumps are particularly suitable for abrasive slurries, where they often outperform other pump types. Since all mechanical components are isolated from the product and only the hose is in contact with the fluid, abrasive wear is minimized.

Products that tend to crystallize can also be pumped efficiently, as there are no valves or glands that could become clogged by crystal build-up.

Corrosive Products

When handling corrosive fluids, correct hose material selection is critical to pump longevity. With the appropriate hose and no other wetted mechanical parts, long service life and safe operation are ensured.

Fluids with Solids or Shear-Sensitive Products

Fluids containing solid particles – such as wastewater with gravel, wood fragments, concrete residues, or food products – can be transferred easily thanks to the unobstructed hose passage.

ACME pumps are also ideal for shear-sensitive or foamy products, as the gentle, non-emulsifying pumping action preserves product integrity and consistency.

Viscous Products

The strong self-priming capability allows ACME pumps to generate near-vacuum conditions, making them ideal for transferring highly viscous materials such as honey, grout, resins, or sludge – applications that are challenging for many other pump types.

Environmental Applications

There are two main environmental applications for pumps:

- Chemical dosing
- Sludge transfer

1) Chemical dosing

Commonly used for sodium hypochlorite, sodium bisulfite, ferric chloride, polymers, lime slurry, and carbon slurry. In particular, when pumping sodium hypochlorite – which releases gas – the pump maintains efficiency by pumping liquid and gas simultaneously without air-lock issues.

2) Sludge transfer





Pumps can handle a wide range of sludges, depending on the treatment stage of the plant, including thickened sludge, waste activated sludge, return activated sludge, and corrosive sludge.

TUBING CHART

Material	Color	Applications	T OPR °C	T MAX °C	AS Series	ASP Series	ATR Series
Silicone	Red tube	Non-aggressive chemical products	120	150	Yes	No	No
Acmeprene	Cream tube	Alcoholic products, diluted acids, alkalis, oils and abrasives	100	130	Yes	No	No
Acmeprene FDA	Cream tube	Food, pharmaceutical and chemical products, alkalis, oils, diluted acids	100	130	Yes	No	No
NR	Green stripe	Abrasive, saline, alkaline, alcoholic products	60	80	Yes (size 20/25)	Yes	Yes
NR Food	Black tube with white inner layer	Non-fatty food products	50	70	Yes (size 25)	Yes	Yes
NBR	Red stripe	Oily products, fats, hydrocarbons and hydrocarbon solvents	40	60	Yes (size 25)	Yes	Yes
NBR Food	Black tube with red stripe and white inner layer	Fatty food products such as vegetable and animal oils	40	60	Yes (size 25)	Yes	Yes
EPDM	White stripe	Non-aggressive chemicals, diluted acids, alkalis, saline solutions	60	80	Yes (size 25)	Yes	Yes
Hypalon	Yellow stripe	Chemicals, acids, alkalis, solvents, oxidizing agents, alcohol, salts and hydrocarbons	60	90	Yes (size 25)	Yes	Yes
Special	For very demanding applications in terms of chemical compatibility, we offer a selection of special tubes in Viton, Tygon and Chem Durance						

CODES TABLE

AS-	15-	FX-	23-
MODEL	SIZE	TYPE	MAX. RPM
AS- Peristaltic dosing pumps Low pressure	10-	FX- FIXED FLOW RATE	VIEW ON THE PRODUCT TECHNICAL DATA
	15-	FXS FIXED FLOW-RATE WITH COOLING DEVICE	
	20-	VX- MECHANICAL VARIATOR	
	25-	VXS MECHANICAL VARIATOR WITH COOLING DEVICE	
		IX1 MOTOR-INVERTER SINGLEPHASE	
		IX3 MOTOR-INVERTER THREEPHASE	
		RX- PUMP HEAD GEAR BOX - NO MOTOR	
		TX- PUMP HEAD	
ASP- Peristaltic pumps High pressure	10-	FX- FIXED FLOW RATE	
	15-	FXS FIXED FLOW-RATE WITH COOLING DEVICE	
	20-	VX- MECHANICAL VARIATOR	
	25-	VXS MECHANICAL VARIATOR WITH COOLING DEVICE	
	32-		
	40-	IX1 MOTOR-INVERTER SINGLEPHASE	
	50-		
	65-	IX3 MOTOR-INVERTER THREEPHASE	
		RX- PUMP HEAD GEAR BOX - NO MOTOR	
		TX- PUMP HEAD	
ATR- Peristaltic pumps High pressure and high flow rate	80-	FX- FIXED FLOW RATE	
	280-	FXS FIXED FLOW-RATE WITH COOLING DEVICE	
		IX3 MOTOR-INVERTER THREEPHASE	

S	-NOR	7	S
MOTOR TYPE	TUBE MATERIAL	CONNECTIONS	CONNECTIONS MATERIALS
<p>X ATEX</p> <p>S SINGLE-PHASE</p> <p>T THREE-PHASE</p>	<p>-SIL SILICONE</p> <p>-TPF ACMEPRENE FDA</p> <p>-TPV ACMEPRENE</p>	<p>1 BSP THREADED (AS not available)</p> <p>2 FLANGED</p> <p>3 TRI-CLAMP</p>	<p>SS SS High level of corrosion and abrasion resistance.</p>  <p>P POLYPROPYLENE Wide chemical compatibility. General purpose.</p> 
	<p>--NR NATURAL RUBBER</p> <p>-NRF NR FOOD GRADE</p> <p>-NBR NITRILE</p> <p>NBRF NITRILE FOOD GRADE</p> <p>-HYP HYPALON</p> <p>EPDM EPDM</p> <p>-EPF EPDM FOOD GRADE</p> <hr/> <p>--NR NATURAL RUBBER</p> <p>-NRF NR FOOD GRADE</p> <p>-NBR NITRILE</p> <p>-HYP HYPALON</p> <p>EPDM EPDM</p>	<p>5 NPT THREADED (AS not available)</p> <p>6 DIN 11851</p> <p>7 HOSE BARB (Standard)</p>	<p>K PVDF Strong chemical resistance to acids. High temperature resistance.</p>  <p>T PTFE Widest chemical compatibility, extreme corrosion resistance, non-adhesive, high heat resistance.</p>  <p>C PVC Good chemical resistance to many acids and bases. Good corrosion resistance and versatile use.</p> 

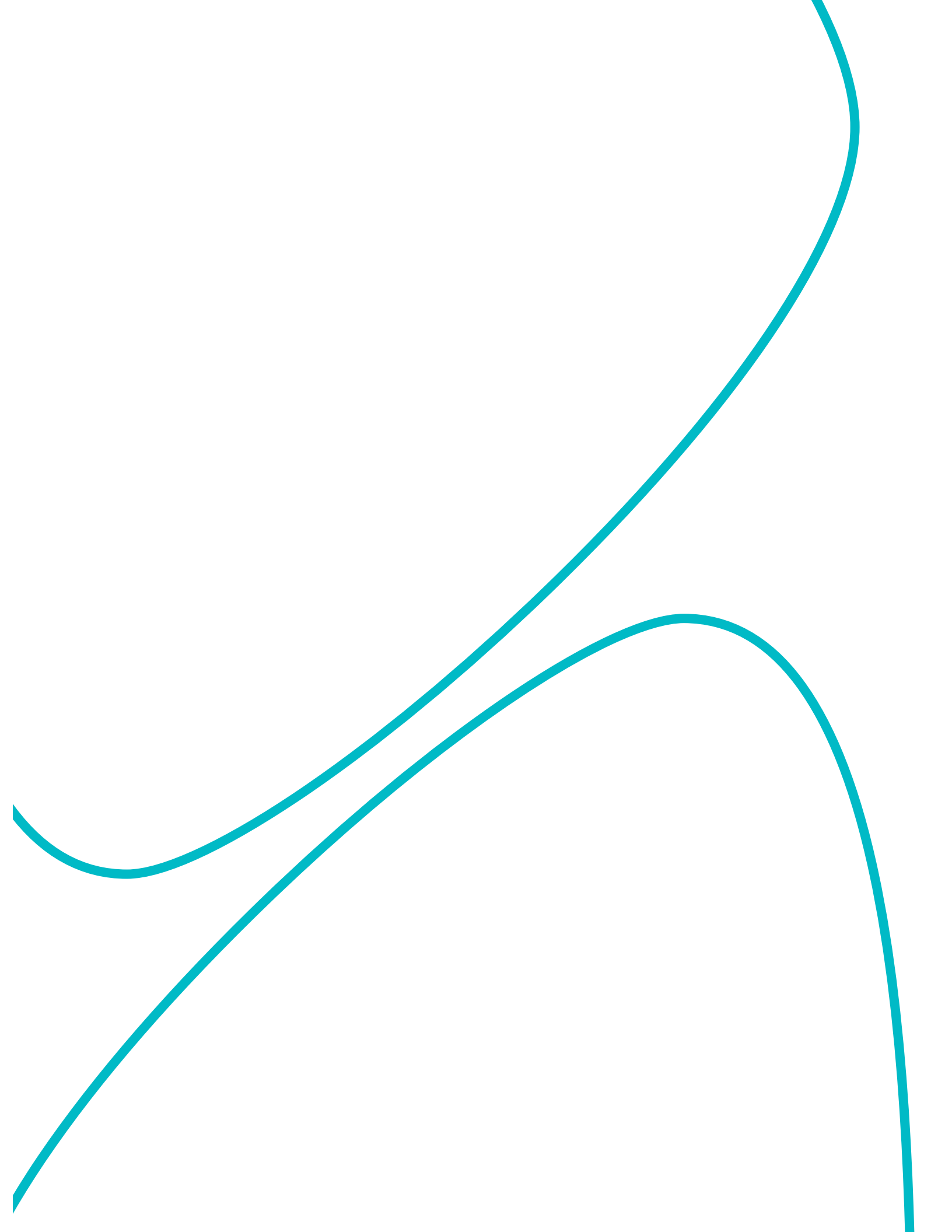

AS SERIES PERISTALTIC PUMPS

Low pressure peristaltic dosing units
Flow rates from 1.5 to 1785 l/h
Pressures from 1.5 to 4 bar



AS SERIES

The **AS series peristaltic pumps**, manufactured by our company, are designed to handle small transfers and precision dosing at low pressures. They can manage moderately viscous fluids containing fair amounts of suspended solids. They ensure a gentle transfer of both industrial and food-grade fluids.

RANGE OF PERFORMANCE

Low pressure peristaltic dosing units Flow rates from 1.5 to 1785 L/h Pressures from 1.5 to 4 bar

MAIN APPLICATIONS

- Dosing of chemicals containing solid particles or prone to crystallization
- Dosing of creams, sauces, gravies, and other food fluids
- Feeding of filling machines
- Dosing of glues and adhesives

THE RANGE INCLUDES THE FOLLOWING CONFIGURATIONS

AS FX SERIES

Fixed flow pumps



AS VX SERIES

Variable flow pumps with mechanical variator



AS IX SERIES

Variable flow pumps with separate frequency variator



AS IMX SERIES

Variable flow pumps with integrated frequency variator



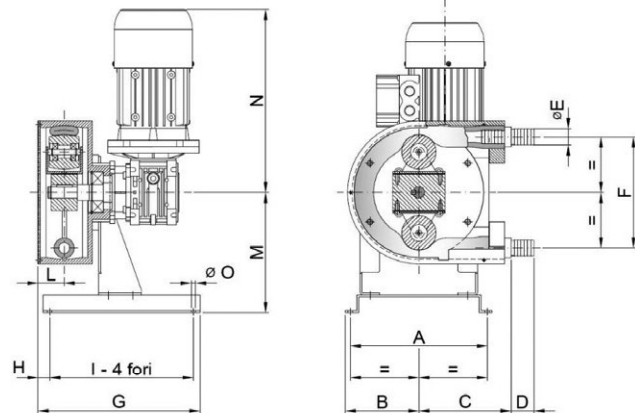
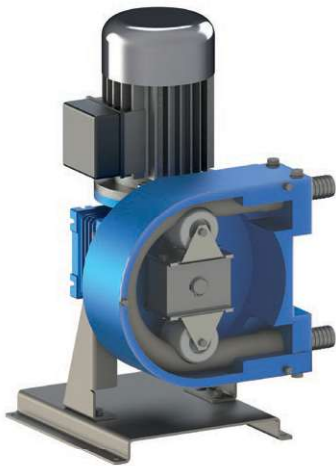

Water treatment plants, wastewater, chemical and petrochemical industry, paper mills, textile industry, ceramic industry, construction, mining industry, paints and inks, emulsifiable oils, food and dairy industry, pasta factories, wine-making and bottling sector, pharmaceutical and cosmetic industry, tanneries.

SUITABLE FOR

- abrasive products
- acidic products
- sensitive products
- viscous products
- dense products
- dosing applications
- vacuum applications
- use in explosive environments

DIMENSIONS

	A	B	C	D	E	F	G	H	I	L	M	N	O	Kg
AS 10 FX	172	92	92	20	15	104	185	12	166	28	137	245	7	9
AS 15 FX	172	92	110	20	20	127	183	12	166	30	137	245	7	10
AS 20 FX	210	112	142	35	25	175	248	18	220	40	184	260	7	18
AS 25 FX	250	146	210	45	32	254	386	81	290	52	228	370	11	40

TECHNICAL DATA

	Q(L/H)	A	P	RPM	I	KW	di	Qu	Nm
AS 10 FX	23	4	15	23	60	0,18	9	0,017	6
	35	4	15	35	40	0,18			
	47	4	15	47	30	0,18			
	70	4	15	70	20	0,18			
	93	4	15	93	15	0,18			
AS 15 FX	56	4	15	23	60	0,18	13	0,041	12
	86	4	15	35	40	0,18			
	115	4	15	47	30	0,18			
	172	4	15	70	20	0,18			
	228	4	15	93	15	0,18			
AS 20 FX	149	5	*15-40	23	60	0,18	17	0,108	20
	227	5	*15-40	35	40	0,18			
	305	5	*15-30	47	30	0,18			
	453	5	*15-30	70	20	0,18			
	602	5	*10-20	93	15	0,18			
AS 25 FX	538	6	*20-40	28	60	0,37	25	0,320	30
	672	6	*20-40	35	40	0,37			
	902	6	*20-30	47	30	0,37			
	1344	6	*20-30	70	20	0,75			
	1785	6	*15-20	93	15	0,75			

* = according to the hose used
A = suction in m

P = head in m
di = inside diameter of hose

Qu = liters per revolution
Nm = min.starting torque

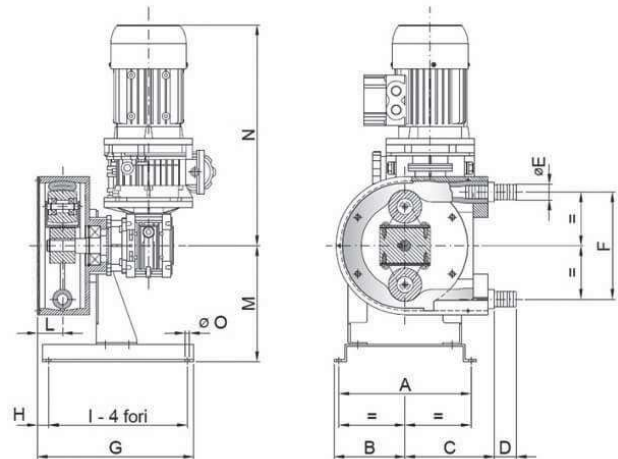

Water treatment plants, wastewater, chemical and petrochemical industry, paper mills, textile industry, ceramic industry, construction, mining industry, paints and inks, emulsifiable oils, food and dairy industry, pasta factories, wine-making and bottling sector, pharmaceutical and cosmetic industry, tanneries.

SUITABLE FOR

- abrasive products
- acidic products
- sensitive products
- viscous products
- dense products
- dosing applications
- vacuum applications
- use in explosive environments

DIMENSIONS

	A	B	C	D	E	F	G	H	I	L	M	N	O	Kg
AS 10 VX	172	92	92	20	15	104	185	12	166	28	137	328	7	12
AS 15 VX	172	92	110	20	20	127	183	12	166	30	137	328	7	13
AS 20 VX	210	112	142	35	25	175	248	18	220	40	184	343	7	22
AS 25 VX	250	146	210	45	32	254	386	81	290	52	228	476	11	45

TECHNICAL DATA

	Q(L/H)	A	P	RPM	I	KW	di	Qu	Nm
AS 10 VX	3,2-15	4	15	3,2-15	60	0,22	9	0,017	6
	4,7-22,5	4	15	4,7-22,5	40	0,22			
	6,3-30	4	15	6,3-30	30	0,22			
	9,5-45	4	15	9,5-45	20	0,22			
	19-90	4	15	19-90	10	0,22			
AS 15 VX	7,8-37	4	15	3,2-15	60	0,22	13	0,041	12
	11,6-55	4	15	4,7-22,5	40	0,22			
	15,5-73,8	4	15	6,3-30	30	0,22			
	23,4-110	4	15	9,5-45	20	0,22			
	47-221	4	15	19-90	10	0,22			
AS 20 VX	21-97	5	*15-40	3,2-15	60	0,22	17	0,108	20
	30-146	5	*15-30	4,7-22,5	40	0,22			
	41-194	5	*15-30	6,3-30	30	0,22			
	62-291	5	*15-25	9,5-45	20	0,22			
	82-388	5	*15-20	12,7-60	15	0,22			
AS 25 VX	73-365	6	*15-40	3,8-19	50	0,37	25	0,320	30
	90-455	6	*15-40	4,7-23,7	40	0,37			
	121-912	6	*15-30	9,5-47,5	20	0,37			
	182-	6	*15-35	6,3-31,7	30	0,75			
	243-1280	6	*15-25	12,7-66,7	15	0,75			

* = according to the hose used

A = suction in m

P = head in m

di = inside diameter of hose

Qu = liters per revolution

Nm = min.starting torque

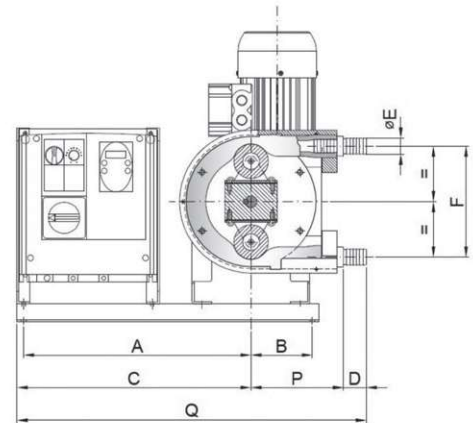
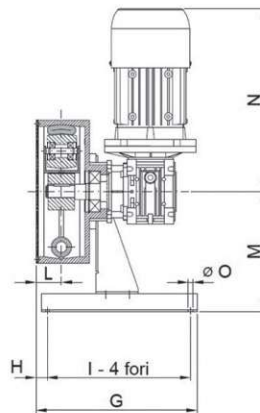

Water treatment plants, wastewater, chemical and petrochemical industry, paper mills, textile industry, ceramic industry, construction, mining industry, paints and inks, emulsifiable oils, food and dairy industry, pasta factories, wine-making and bottling sector, pharmaceutical and cosmetic industry, tanneries.

SUITABLE FOR

- abrasive products
- acidic products
- sensitive products
- viscous products
- dense products
- dosing applications
- vacuum applications
- use in explosive environments

DIMENSIONS

	A	B	C	D	E	F	G	H	I	L	M	N	O	P	Q	Kg
AS 10 IX	318	68	325	20	15	104	215	37	172	28	137	270	7	92	437	15
AS 15 IX	318	68	325	20	20	127	219	41	172	30	137	270	7	110	455	16
AS 20 IX	348	94	358	35	25	175	245	28	210	40	184	280	7	142	535	25
AS 25 IX	380	125	400	45	32	254	417	47	358	52	255	390	11	210	656	49

TECHNICAL DATA

	Q(L/H)	A	P	RPM	I	KW	di	Qu	Nm
AS 10 IX	1,5 ÷ 47	4	15	1,5 ÷ 47	60	0,18	9	0,017	6
	3 ÷ 93	4	15	3 ÷ 93	30	0,18			
	6 ÷ 185	4	15	6 ÷ 185	15	0,18			
AS 15 IX	3,7 ÷ 115	4	15	1,5 ÷ 47	60	0,18	13	0,041	12
	7 ÷ 172	4	15	2,8 ÷ 70	40	0,18			
	15 ÷ 345	4	15	6 ÷ 140	20	0,18			
AS 20 IX	10 ÷ 304	5	*15-40	1,5 ÷ 47	60	0,18	17	0,108	20
	18 ÷ 453	5	*15-40	2,8 ÷ 70	40	0,18			
	20 ÷ 602	5	*15-30	3 ÷ 93	30	0,18			
AS 25 IX	29 ÷ 902	6	*20-40	1,5 ÷ 47	60	0,37	25	0,320	30
	54 ÷ 1344	6	*20-40	2,8 ÷ 70	40	0,55			
	58 ÷ 1785	6	*15-25	3 ÷ 93	30	0,75			

* = according to the hose used

A = suction in m

P = head in m

di = inside diameter of hose

Qu = liters per revolution

Nm = min.starting torque

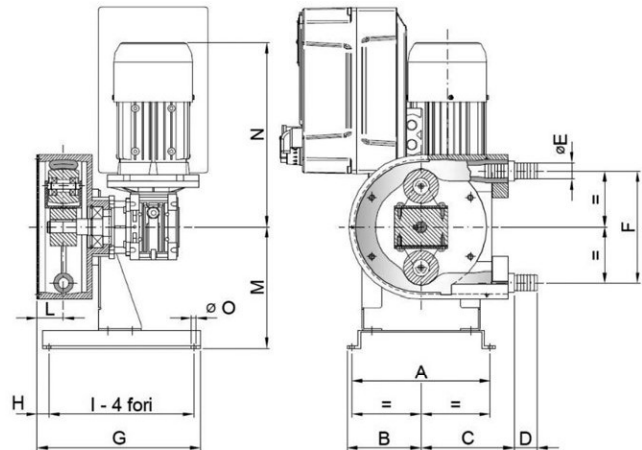

Water treatment plants, wastewater, chemical and petrochemical industry, paper mills, textile industry, ceramic industry, construction, mining industry, paints and inks, emulsifiable oils, food and dairy industry, pasta factories, wine-making and bottling sector, pharmaceutical and cosmetic industry, tanneries.

SUITABLE FOR

- abrasive products
- acidic products
- sensitive products
- viscous products
- dense products
- dosing applications
- vacuum applications
- use in explosive environments

DIMENSIONS

	A	B	C	D	E	F	G	H	I	L	M	N	O	Kg
AS 10 IMX	172	92	92	20	15	104	185	12	166	28	137	245	7	9
AS 15 IMX	172	92	110	20	20	127	183	12	166	30	137	245	7	10
AS 20 IMX	210	112	142	35	25	175	248	18	220	40	184	260	7	18
AS 25 IMX	250	146	210	45	32	254	386	81	290	52	228	370	11	40

TECHNICAL DATA

	Q(L/H)	A	P	RPM	I	KW	di	Qu	Nm
AS 10 IMX	1,5 ÷ 47	4	15	1,5 ÷ 47	60	0,18	9	0,017	6
	3 ÷ 93	4	15	3 ÷ 93	30	0,18			
	6 ÷ 185	4	15	6 ÷ 185	15	0,18			
AS 15 IMX	3,7 ÷ 115	4	15	1,5 ÷ 47	60	0,18	13	0,041	12
	7 ÷ 172	4	15	2,8 ÷ 70	40	0,18			
	15 ÷ 345	4	15	6 ÷ 140	20	0,18			
AS 20 IMX	10 ÷ 304	5	*15-40	1,5 ÷ 47	60	0,18	17	0,108	20
	18 ÷ 453	5	*15-40	2,8 ÷ 70	40	0,18			
	20 ÷ 602	5	*15-30	3 ÷ 93	30	0,18			
AS 25 IMX	29 ÷ 902	6	*20-40	1,5 ÷ 47	60	0,37	25	0,320	6
	54 ÷ 1344	6	*20-40	2,8 ÷ 70	40	0,55			
	58 ÷ 1785	6	*15-25	3 ÷ 93	30	0,75			

* = according to the hose used

A = suction in m

P = head in m

di = inside diameter of hose

Qu = liters per revolution

Nm = min.starting torque

AS SERIES PERFORMANCE CURVES

AS 10

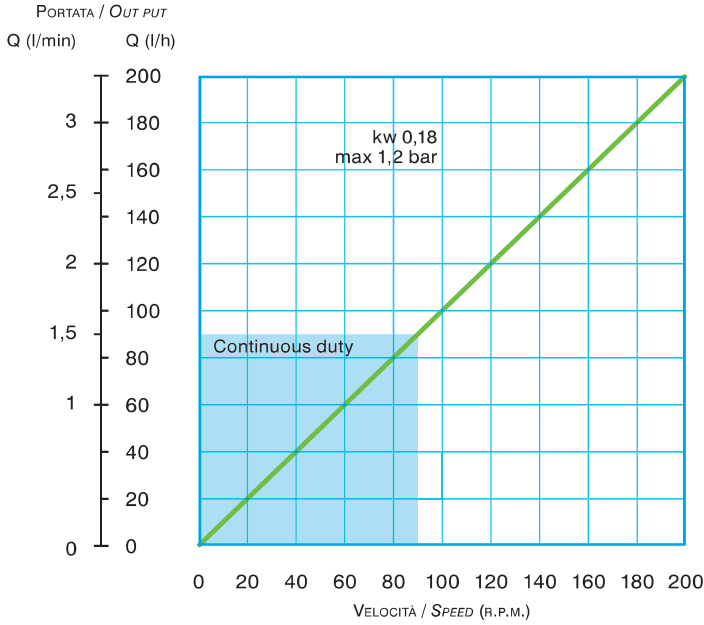

AS 15

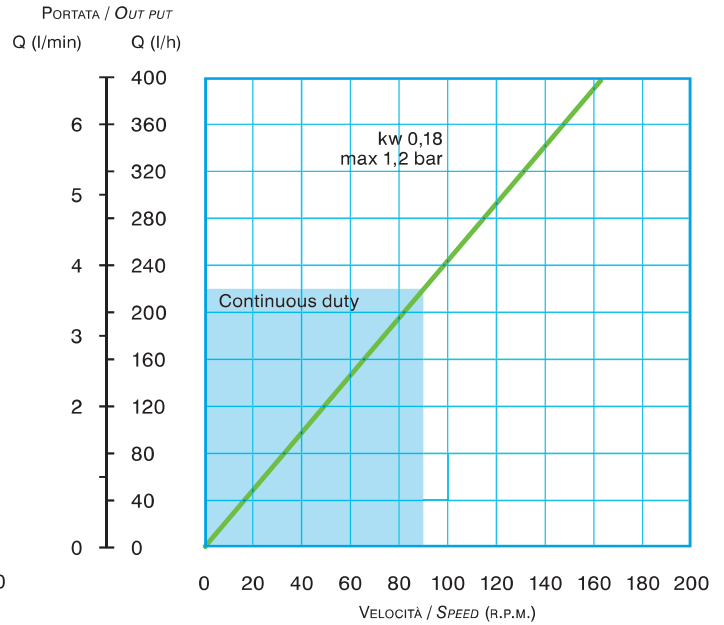

AS 20

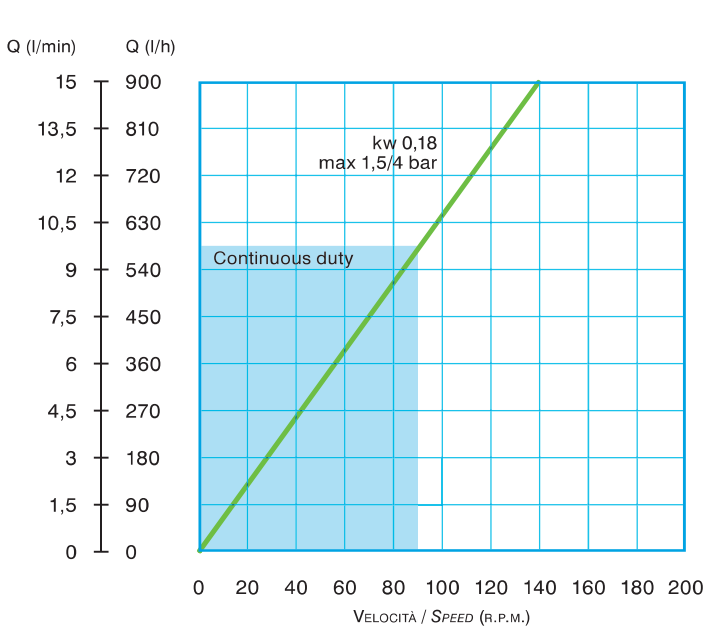

AS 25

