

AODD PUMPS

www.acmepompe.it

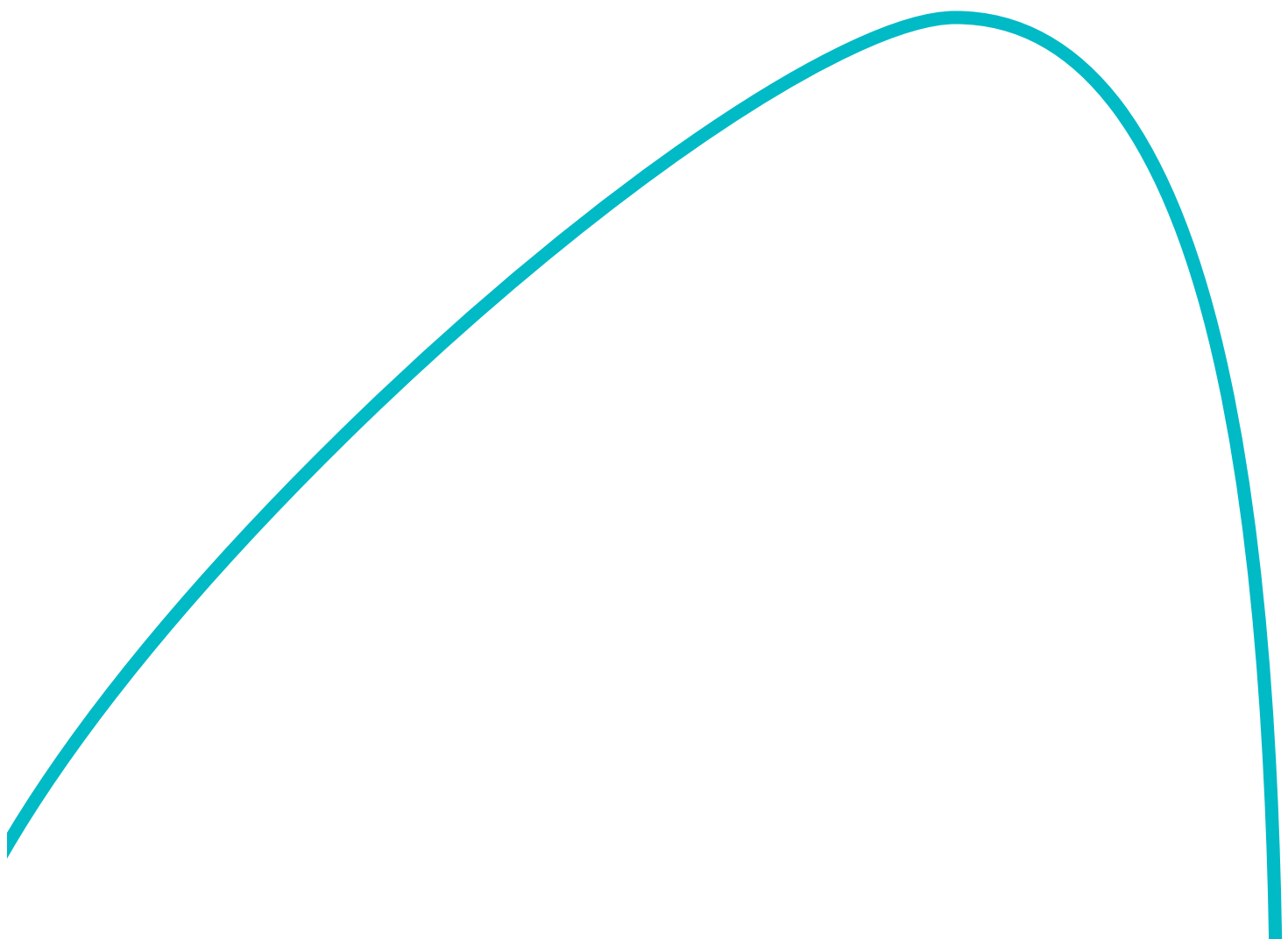



INDEX

ACME

Our company

4

Air-operated double-diaphragm pumps

Operation, Installation, Technical data sheet

7

AMP pneumatic pumps

AMP 4, AMP 8, AMP 20, AMP35, AMP 55, AMP 60, AMP 90, AMP 120,
AMP 170, AMP 252, AMP 400, AMP 700, AMP 1000

13

AMP Food pneumatic pumps

AMPF 20, AMPF 35, AMPF 60, AMPF 120, AMPF 170, AMPF 400,
AMPF 700, AMPF 1000

27

AMP special pneumatic pumps

AMP Atex, Accurate AMP, Flap AMP, Steel AMP,
Drum AMP, Twin AMP, Submersible AMP, Power AMP

33

Damper

Pulsation dampers

39

AML pneumatic pumps

AML 10, AML 15, AML 25, AML 40

43

Accessories

51

ACME – CLEVER PUMPS INNOVATIVE SOLUTIONS FOR FLUID TRANSFER AND DOSING SINCE 1992

Founded in 1992, ACME Pumps quickly established itself as one of the leading manufacturers of industrial peristaltic pumps, air-operated double diaphragm pumps, centrifugal pumps and diaphragm metering pumps. With decades of experience supporting businesses across various sectors, our mission is to deliver highly specialized, tailor-made pumping solutions, solving complex challenges and meeting the unique needs of every customer.

Headquarters and Production Facility

ACME's headquarters and manufacturing facility are located in Santo Stefano Ticino, just 25 km west of Milan and 30 km south of Malpensa Airport (MXP). This strategic location allows us to efficiently serve both national and international clients, offering excellent logistical connections for shipments and customer support. Our facility houses both the production plant and the commercial offices, enabling close coordination between our technical and sales teams to ensure fast, customized service.

A Dynamic, Customer-Focused Company

ACME is a lean and flexible organization, able to adapt swiftly to market demands. Our customer-centric approach is reflected in our unique ability to respond to specific and customized requests. Thanks to our strong design expertise and long-standing partnerships with trusted suppliers, we can handle demand surges and provide prompt, reliable solutions—even through well-established subcontracting agreements.

High-Quality Products for Every Industrial Sector

ACME offers a wide range of AODD pumps, ideal for dosing and transferring fluids in a variety of industrial applications. Sizes range from 1/4" to 3", with flow rates between 1 and 1,050 L/min. Flow is adjustable on all models simply by regulating the air inlet pressure and flow. Thanks to FDA and ATEX certifications, our pumps are fully qualified to operate in the food and pharmaceutical industries, as well as in any environments classified as potentially explosive.

ACME pumps are used across a wide range of industries, including:

- Water purification, wastewater treatment, aquariums, marine and naval sectors
- Chemical, pharmaceutical, and cosmetics industries
- Winemaking, food, and dairy sectors
- Paints, inks, paper mills, and tanneries
- Construction, cement and ceramic plants
- Oil & Gas sector, refineries, and fuel storage facilities.

Thanks to their durability and versatility, our pumps are ideal for transferring and dosing challenging fluids such as corrosive, abrasive, viscous liquids, or those with solid suspensions. They are designed to handle intermittent flow, difficult suction conditions, and can run dry for extended periods.

Our Mission and Commitment to Quality

Our mission is clear: to deliver specific, customized pumping solutions with the customer always at the center. To ensure maximum reliability, we are constantly improving our products and manufacturing processes. Quality is our hallmark, achieved through:

- Long-standing collaborations with trusted suppliers





- Careful selection of materials and components
- Strict control over the entire production process
- Specialized expertise within our team

A Leading International Brand

Driven by the professionalism and passion of our team, ACME has grown steadily over the years, strengthening its presence both in the local and international markets. Today, we are recognized as one of the key players in the pump sector, and we continue to expand our reach to meet the needs of an increasingly demanding market.

Our Product Range

Our range of pumps includes:

- **Peristaltic pumps** – ideal for dosing and transferring viscous fluids with solid particles
- **Double diaphragm pneumatic pumps** – suitable for aggressive industrial fluids
- **Diaphragm dosing pumps** – designed for applications requiring precise dosing

- **Mag-drive and mechanically sealed centrifugal pumps** – for pulse-free transfer of low-viscosity fluids
- **Drum and IBC transfer pumps** – designed for direct liquid transfer from drums or IBC tanks

Core Values

At the heart of our corporate philosophy lies the customer and a strong commitment to compliance and ethical standards. Every member of our internal and external teams is dedicated to providing solutions that are competent, reliable, and timely.

Conclusion

For over 30 years, ACME Clever Pumps has stood for quality, innovation, and reliability in the industrial pump industry. Backed by decades of experience and a drive for continuous innovation, we are ready to support every customer—facing today's challenges and shaping tomorrow's solutions together.



















































AIR-OPERATED DOUBLE-DIAPHRAGM PUMPS

Flow-rate from 4 lt/min to 1.050 lt/min.
Special versions available



IDENTIFICATION CODES TABLE

AMP	0120	P-	HT	T
MODEL	SIZE	CASING	DIAPHRAGMS	BALLS
AMP AMP 	4 4 lt/min 1/4" BSPP	 P POLYPROPYLENE Wide chemical compatibility. General usage. Reinforced with fiberglass.	 H HYTREL Good resistance to low temperatures and abrasion.	N NBR Suitable for petroleum-based fluids, water, oils, hydrocarbons and mild chemicals.
AMPF AMP FOOD 	8 7 lt/min 1/4" BSPP	 PC CONDUCTIVE POLYPROPYLENE Wide chemical compatibility. General usage. ATEX-compliant.	 W SANTOPRENE HIGH RESISTANCE Solutions and diluted acids.	 D EPDM Suitable for alkaline solutions, diluted acids, ketones and alcohols. Good abrasion resistance.
AMAP ACCURATE AMP 	20 20 lt/min 3/8" BSPP	 KC CONDUCTIVE PVDF Strong chemical resistance to acids and high temperatures. ATEX-compliant.	 NBR NBR Suitable for petroleum-based fluids, water, oils, hydrocarbons and mild chemicals.	 T PTFE Wide chemical compatibility, extreme corrosion resistance, anti-adhesive properties, and high heat resistance.
AMTP TWIN AMP 	35 35 lt/min 1/2" BSPP	 O ACETAL Resistant to a wide range of solvents and hydrocarbons. Good abrasion resistance. (available only in sizes 4, 8 and 10).	 D EPDM Suitable for alkaline solutions, diluted acids, ketones and alcohols. Good abrasion resistance.	 S SS Excellent resistance to corrosion and abrasion. Suitable for viscous fluids.
AMPP POWDER AMP 	60 65 lt/min 1/2" BSPP	 OC CONDUCTIVE ACETAL Resistant to a wide range of solvents and hydrocarbons. Good abrasion resistance. (available only in sizes 4, 8 and 10). ATEX-compliant.	 HT HYTREL + PTFE Wide chemical compatibility, extreme corrosion resistance, anti-adhesive properties, and high heat resistance.	 MT SANTOPRENE + PTFE Suitable for alkaline solutions, diluted acids, ketones and alcohols. Good abrasion resistance.
AMPS SUBMERSIBLE AMP 	90 100 lt/min 3/4" BSPP	 A ALUMINUM Resistant to a wide range of solvents and hydrocarbons. Good abrasion resistance.	 SS SS - AISI 316 ELECTROPOLISHED Excellent resistance to corrosion and abrasion. Food version available.	
AMDP DRUM AMP 	120 120 lt/min 1" BSPP			
AMPS SUBMERSIBLE AMP 	170 170 lt/min 1" BSPP/DN25			
AMDP DRUM AMP 	252 250 lt/min 1" 1/4 BSPP			
AMFP FLAP AMP 	400 380 lt/min 1" 1/2 BSPP DN40			
	700 700 lt/min 2" BSPP DN50			
	1000 1050 lt/min 3" BSPP DN80			

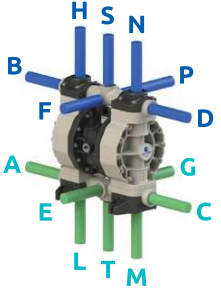
P	V	1	-	AB
BALL SEATS	GASKETS	CONNECTIONS	ATEX ZONE CERTIFICATION	PORTS
<p>P POLYPROPYLENE Wide chemical compatibility. General usage.</p>  <p>K PVDF Strong chemical resistance to acids and high temperatures.</p>  <p>S SS Excellent resistance to corrosion and abrasion.</p>  <p>Z PE Suitable for fluids with high molecular weight. High abrasion resistance. (available only with D and N balls).</p>  <p>O ACETAL Resistant to a wide range of solvents and hydrocarbons. Good abrasion resistance.</p> 	<p>V VITON High heat resistance. Good resistance to aggressive chemicals and hydrocarbons.</p>  <p>N NBR Suitable for petroleum-based fluids, water, oils, hydrocarbons and mild chemicals.</p>  <p>D EPDM Suitable for alkaline solutions, diluted acids, ketones and alcohols. Good abrasion resistance.</p>  <p>T PTFE Wide chemical compatibility, extreme corrosion resistance, anti-adhesive properties, and high heat resistance.</p> 	<p>1 BSP THREADED</p> <p>A BSP THREADED WITH REINFORCED RING</p> <p>2 FLANGED</p> <p>3 TRI-CLAMP (AMP FOOD)</p> <p>5 NPT THREADED</p> <p>E NPT THREADED WITH REINFORCED RING</p> <p>6 DIN 11851/3 (AMP FOOD)</p>	<p></p> <p>- ATEX ZONE 2 From P4 to P120 models  II 3/3 G Ex h IIC T4 Gc  II 3 D Ex h IIIB T135°C Dc X</p> <p>From P170 to P1000 models  II 3/3 G Ex h IIB T4 Gc  II 3 D Ex h IIIB T135°C Dc X</p> <p>X ATEX ZONE 1 From P4 to P120 models  III 2/2 G Ex h IIC T4 Gb  II 2 D Ex h IIIB T135°C Db X</p> <p>From P170 to P1000 models  II 2/2 G Ex h IIB T4 Gb  II 2 D Ex h IIIB T135°C Db X</p>	
<p>SPECIAL FEATURES</p> <p>AMSP STAINSTEEL AMP central block made of stainless steel</p> <p>AMSCP STROKE COUNTER AMP with external pneumatic signal</p> <p>AMPCR AMP with shorter strokes</p> <p>AMPCL AMP with longer strokes</p>				

PUMP OPERATION



◆ Fluid ◆ Air

1 - SUCTION CYCLE

Compressed air fills the right inner chamber. The movement of the opposing diaphragm lifts the lower valve ball, creating suction and drawing fluid through the inlet. At the same time, the left chamber is in the "Discharge" cycle.

2 - DISCHARGE CYCLE

Compressed air fills the left inner chamber. The opposing chamber, by lifting the upper valve, discharges fluid. At the same time, the right chamber is in the "suction" cycle.

INSTALLATION



Pump installed below head (positive suction)

Used when the tank must be completely emptied



Self-priming pump installed above head (negative suction)

Easily handles initial dry suction



Pump installed above drum or tank

Special-feature pump

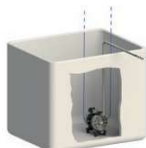

Submerged pump

Chemical compatibility must be verified



Pump installed on hopper for high viscosity fluids

The hopper's height helps the pump in moving the fluid. Air pressure has to be high, and a suction tube needs to be bigger than the pump's size



Suspended

Special version for ceiling fixing that comes with additional feet in the upper part



Pump installed on a mobile unit

The trolley or cart facilitates easy handling of the pump

TECHNICAL DATA SHEET

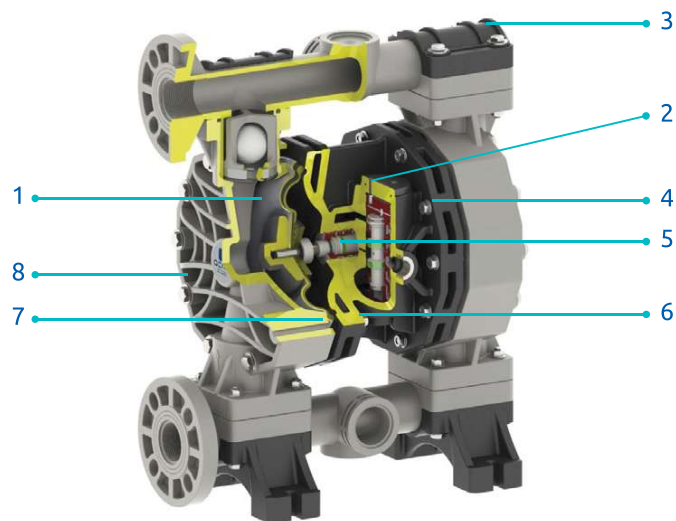

- 1** Long-lasting diaphragms that ensure a consistent performance and longer operating life.
- 2** Efficient design of the pneumatic exchanger ensures low air consumption. An unbalanced pilot spool precisely controls the positioning of the main power spool, eliminating stalling and increasing efficiency.
- 3** All-bolted design ensures effective sealing and maximum safety.
- 4** Solid polypropylene air chambers and plastic air valve ensure maximum chemical resistance in highly corrosive environments.
- 5** Acetal pneumatic exchanger and bushings provide long-lasting resistance thanks to self-lubrication.
- 6** The pneumatic exchanger is easily accessible from the outside for quick inspection. The air system is lube-free, antistall and antifreeze.
- 7** Special diaphragm clamping, designed to minimize wear and increase service life, while providing a secure, hermetic and leak-proof seal.
- 8** Exhaust chamber with double silencer designed to enhance diffusion passages, reduce freezing, and ensure low noise levels.

- ◆ Wide range of flow rates and materials suitable for various conditions and fluids
- ◆ Safe "dead head" operation: with a closed discharge the pump will not be damaged
- ◆ Suitable for handling of liquids containing solids particles
- ◆ Fully submersible: can be entirely immersed, depending on fluid compatibility
- ◆ Serviceability: easily and quickly maintained with no special tools required
- ◆ High performance thanks to an optimal and functional design
- ◆ Self-priming: capable of dry suction up to 6 meters
- ◆ Seal-less design: dry-run without damaging the pumping system

QUALITY 100% of the pumps are tested with water after final assembly

SAFETY ATEX certification on all versions: conductive plastic pumps available

FLEXIBILITY Multiple porting options and connection types available



PUMP SELECTION

To select the appropriate pump model based on the intended application, the following factors should be considered in order to optimize performance, extend service life, and minimize maintenance costs:

- The nature of the fluid to be pumped, its viscosity, and the solids particles it may contain;
- The pump capacity in relation to the required flow rate;
- Suction and discharge (head) conditions;

Taking these parameters into account, the correct pump is selected when the intersection of the “head” and “flow rate” axes on the performance curve is near the center section of the graph.

PERFORMANCE CURVES

To determine the compressed air requirements and the proper size for a ACME AODD pump, two pieces of information are necessary:

- 1 Required flow rate
- 2 Total delivery head

For example, consider the P170 pump performance curve, which has a pumping capacity of approximately 135 l/min at 25m. Point A on the performance curve is the intersection between the required flow rate and the total delivery head, and it determines the compressed air requirements for this pump. At point A, the pump will require approximately 7 bar of air inlet pressure for proper operation. To verify this, follow the blue curve on the left to read the air pressure in BAR. Then, by following the nearest green curve, it can be seen that the pump will require approximately 900 nl/min (Normal Liter per minute) of air consumption.

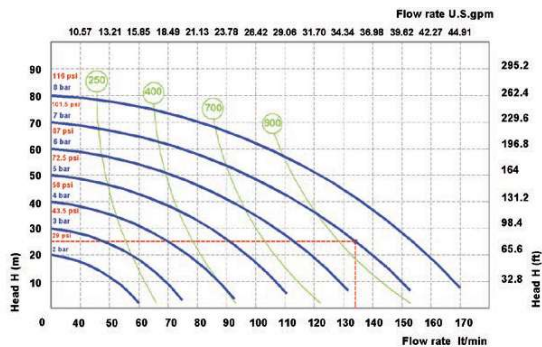

SPECIFIED SUCTION LIFT

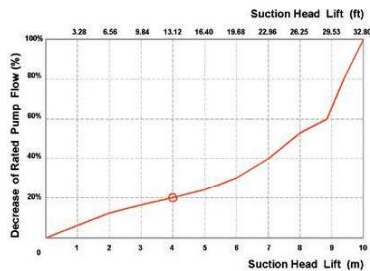

With a suction lift of 4 m, the pump’s flow rate decreases by approximately 20%. This applies to pumps of 3/4” and larger; data varies depending on the pump configuration.

VISCOUS LIQUIDS PERFORMANCE DATA

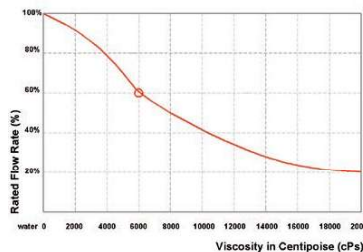

When pumping a fluid with a viscosity of 6000 cps, the pump’s flow rate decreases by 60% of its rated value (100% = water). This applies to pumps of 3/4” and larger.

Pump Type	AODD	Centrifugal	Lobe	Gear	Screw	Peristaltic	Piston
Variable Flow & Head Control	◆	◆	◆	◆	◆	◆	◆
Deadhead Safety	◆	◆	◆	◆	◆	◆	◆
Dry-Running	◆	◇	◇	◇	◇	◆	◇
Dry Self-Priming	◆	◇	◇	◆	◇	◆	◆
No Mechanical Alignment	◆	◇	◇	◇	◇	◇	◇
No Electrical Installation	◆	◇	◇	◇	◇	◇	◇
Portability	◆	◆	◆	◆	◆	◆	◆
Submersible	◆	◆	◇	◇	◇	◇	◆
Sealless	◆	◆	◆	◆	◆	◆	◆
Cavitation Tolerance	◆	◇	◆	◆	◆	◆	◆
Low Shear & Degradation	◆	◇	◆	◆	◆	◆	◆

◆ = Suitable ◆ = With limitations ◇ = Not recommended

AMP PNEUMATIC PUMPS

AODD pumps

Flow-rate from 4 lt/min to 1.050 lt/min.





PP



PVDF+CF



POMc

TECHNICAL DATA

- Fluid connections 1/4" BSP
- Air connection 1/8" BSP
- Max flow rate 4 lt/min
- Max air pressure 6 bar
- Max delivery head 60 mt
- Max suction lift dry 3 mt
- Max suction lift wet 9,8 mt
- Max solid passing 2 mm
- Noise level 62 dB
- Max viscosity 5.000 cps
- Displacement per stroke 18 CC ~

Ⓜ II 3/3 G Ex h IIC T4 Gc
 Ⓜ II 3 D Ex h IIIB T135°C Dc X

Displacement per stroke may vary based on suction condition, discharge head, air pressure and fluid type.

PERFORMANCE

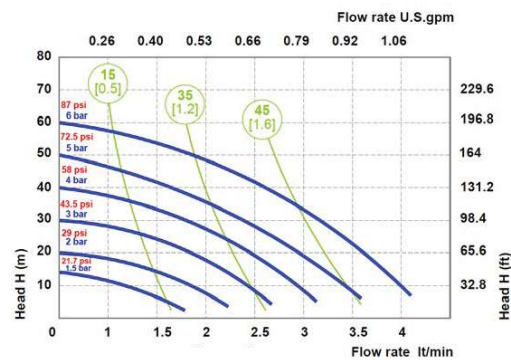

○ Air supply pressure
 ○ Air consumption Nl/min [SCFM]

The curves and performance values refer to pumps with submerged suction and free delivery outlet, with water at 20°C. These data may vary according to the construction materials and hydraulic conditions.

DIMENSIONS

	A	B	C	Weight Kg	Temperature	
PP	129 mm	67 mm	112 mm	0,84 kg	- 4 °C	+ 65 °C
PVDF	129 mm	67 mm	112 mm	0,84 kg	- 20 °C	+ 95 °C
POMc	129 mm	67 mm	112 mm	0,84 kg	- 5 °C	+ 80 °C

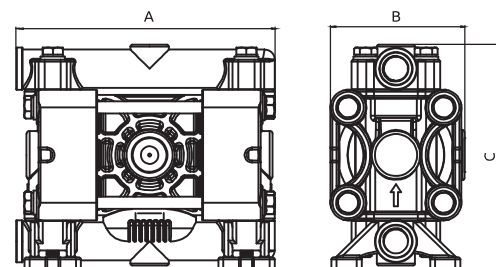

COMPOSITION

MODEL	CASING	DIAPHRAGM	BALLS	SEATS	GASKET	CONNECTIONS	ATEX	PORTS
AMP0004	P = PP KC = PVDF+CF O = POMc	NT = NBR+PTFE	T = PTFE S = SS	P = PP K = PVDF O = POMc	D = EPDM V = VITON N = NBR T = PTFE	1 = BSP A = BSP with ring 5 = NPT E = NPT with ring	- = zone 2	AB = STANDARD



PP



PVDF+CF



POMc

TECHNICAL DATA

- Fluid connections **1/4" BSPP**
- Air connection **1/8" BSPP**
- Max flow rate **7 lt/min**
- Max air pressure **6 bar**
- Max delivery head **60 mt**
- Max suction lift dry **3 mt**
- Max suction lift wet **9,8 mt**
- Max solid passing **2 mm**
- Noise level **62 dB**
- Max viscosity **5.000 cps**
- Displacement per stroke **18 CC ~**

Ⓜ II 3/3 G Ex h IIC T4 Gc
 Ⓜ II 3 D Ex h III B T135°C Dc X

Displacement per stroke may vary based on suction condition, discharge head, air pressure and fluid type.

PERFORMANCE

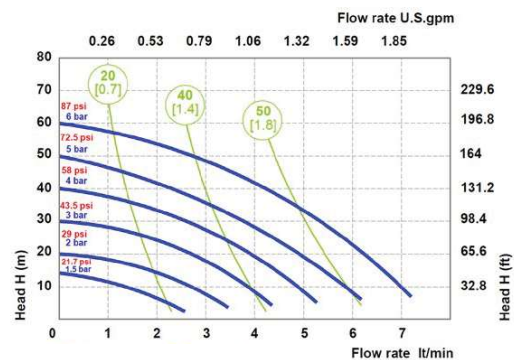

○ Air supply pressure
 ○ Air consumption NL/min [SCFM]

The curves and performance values refer to pumps with submerged suction and free delivery outlet, with water at 20°C. These data may vary according to the construction materials and hydraulic conditions.

DIMENSIONS

	A	B	C	Weight Kg	Temperature	
PP	129 mm	67 mm	112 mm	0,84 kg	- 4 °C	+ 65 °C
PVDF	129 mm	67 mm	112 mm	0,84 kg	- 20 °C	+ 95 °C
POMc	129 mm	67 mm	112 mm	0,84 kg	- 5 °C	+ 80 °C

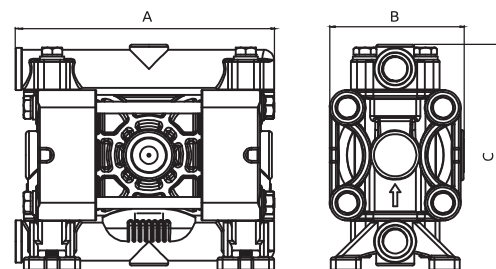

COMPOSITION

MODEL	CASING	DIAPHRAGM	BALLS	SEATS	GASKET	CONNECTIONS	ATEX	PORTS
AMP0008	P = PP KC = PVDF+CF O = POMc	NT = NBR+PTFE	T = PTFE S = SS	P = PP K = PVDF O = POMc	D = EPDM V = VITON N = NBR T = PTFE	1 = BSP A = BSP with ring 5 = NPT E = NPT with ring	- = zone 2	AB = STANDARD

AMP SERIES

AMP 20



PP



PVDF+CF



POMc



SS

TECHNICAL DATA

- Fluid connections 3/8" BSPP
- Air connection 1/4" BSPP
- Max flow rate 20 lt/min
- Max air pressure 7 bar
- Max delivery head 70 mt
- Max suction lift dry 5 mt
- Max suction lift wet 9,8 mt
- Max solid passing 2,5 mm
- Noise level 65 dB
- Max viscosity 10.000 cps
- Displacement per stroke 30 CC ~

II 3/3 G Ex h IIC T4 Gc
II 3 D Ex h IIIB T135°C Dc X

Displacement per stroke may vary based on suction condition, discharge head, air pressure and fluid type.

PERFORMANCE

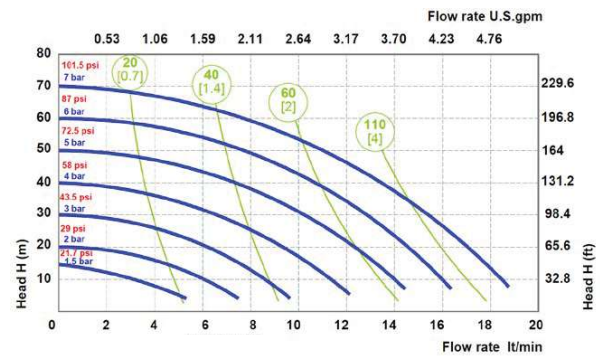

○ Air supply pressure
○ Air consumption Nlt/min [SCFM]

The curves and performance values refer to pumps with submerged suction and free delivery outlet, with water at 20°C. These data may vary according to the construction materials and hydraulic conditions.

DIMENSIONS

	A	B	C	Weight Kg	Temperature	
PP	147 mm	93 mm	170 mm	1,3 kg	- 4 °C	+ 65 °C
PVDF	147 mm	93 mm	170 mm	1,6 kg	- 20 °C	+ 95 °C
POMc	147 mm	93 mm	170 mm	1,5 kg	- 5 °C	+ 80 °C
SS	148 mm	85 mm	152 mm	2,3 kg	- 20 °C	+ 95 °C

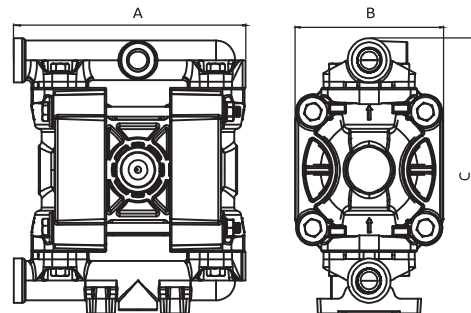

COMPOSITION

MODEL	CASING	DIAPHRAGM	BALLS	SEATS	GASKET	CONNECTIONS	ATEX	PORTS
AMP0020	P = PP KC = PVDF+CF O = POMc S = SS	HT = HYTREL+PTFE MT = SANTOPRENE+PTFE H = HYTREL W = SANTOPRENE H.R.	T = PTFE S = SS	P = PP K = PVDF O = POMc S = SS	D = EPDM V = VITON N = NBR T = PTFE	1 = BSP A = BSP with ring 5 = NPT E = NPT with ring	- = zone 2	AB = STANDARD



PP



PVDF+CF



ALU



SS

TECHNICAL DATA

- Fluid connections 1/2" BSPP
- Air connection 1/4" BSPP
- Max flow rate 35 lt/min
- Max air pressure 7 bar
- Max delivery head 70 mt
- Max suction lift dry 5 mt
- Max suction lift wet 9,8 mt
- Max solid passing 3 mm
- Noise level 65 dB
- Max viscosity 15.000 cps
- Displacement per stroke 65 CC ~

Ⓜ II 3/3 G Ex h IIC T4 Gc
 Ⓜ II 3 D Ex h IIIB T135°C Dc X

Displacement per stroke may vary based on suction condition, discharge head, air pressure and fluid type.

PERFORMANCE

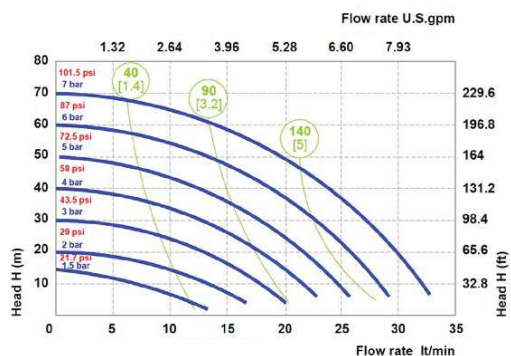

○ Air supply pressure
 ○ Air consumption NL/min [SCFM]

The curves and performance values refer to pumps with submerged suction and free delivery outlet, with water at 20°C. These data may vary according to the construction materials and hydraulic conditions.

DIMENSIONS

	A	B	C	Weight Kg	Temperature	
PP	177 mm	105 mm	186 mm	1,8 kg	- 4 °C	+ 65 °C
PVDF	177 mm	105 mm	186 mm	2,3 kg	- 20 °C	+ 95 °C
ALU	183 mm	110 mm	189 mm	2,8 kg	- 20 °C	+ 95 °C
SS	181 mm	106 mm	192 mm	3,8 kg	- 20 °C	+ 95 °C

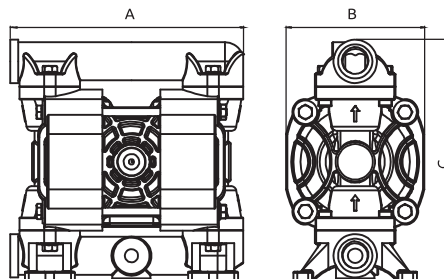

COMPOSITION

MODEL	CASING	DIAPHRAGM	BALLS	SEATS	GASKET	CONNECTIONS	ATEX	PORTS
AMP0035	P = PP	HT = HYTREL+PTFE	T = PTFE	P = PP	D = EPDM	1 = BSP	- = zone 2	AB = STANDARD
	KC = PVDF+CF	MT = SANTOPRENE +PTFE	S = SS	K = PVDF	V = VITON	A = BSP with ring		
	A = ALU	H = HYTREL	D = EPDM	O = POMc	N = NBR	5 = NPT		
	S = SS	W = SANTOPRENE H.R.	N = NBR	Z = PE-UHMWE	T = PTFE	E = NPT with ring		
			S = SS					



PP



PVDF+CF



ALU



SS

TECHNICAL DATA

- Fluid connections 1/2" BSP
- Air connection 1/4" BSP
- Max flow rate 55 lt/min
- Max air pressure 8 bar
- Max delivery head 80 mt
- Max suction lift dry 5 mt
- Max suction lift wet 9,8 mt
- Max solid passing 3,5 mm
- Noise level 70 dB
- Max viscosity 15.000 cps
- Displacement per stroke 140 CC ~

II 3/3 G Ex h IIC T4 Gc
II 3 D Ex h IIIB T135°C Dc X

Displacement per stroke may vary based on suction condition, discharge head, air pressure and fluid type.

PERFORMANCE

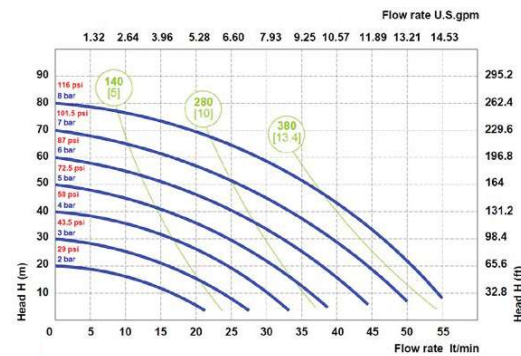

○ Air supply pressure

○ Air consumption Nl/min [SCFM]

The curves and performance values refer to pumps with submerged suction and free delivery outlet, with water at 20°C. These data may vary according to the construction materials and hydraulic conditions.

DIMENSIONS

	A	B	C	Weight Kg	Temperature	
PP	238 mm	156 mm	249 mm	3,8 kg	- 4 °C	+ 65 °C
PVDF	238 mm	156 mm	249 mm	4,8 kg	- 20 °C	+ 95 °C
ALU	234 mm	156 mm	245 mm	3,8 kg	- 20 °C	+ 95 °C
SS	234 mm	156 mm	269 mm	6,8 kg	- 20 °C	+ 95 °C

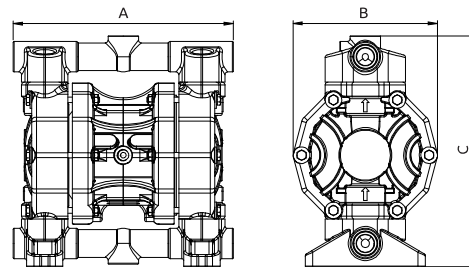

COMPOSITION

MODEL	CASING	DIAPHRAGM	BALLS	SEATS	GASKET	CONNECTIONS	ATEX	PORTS
AMP0055	P = PP	HT = HYTREL+PTFE	T = PTFE	P = PP	D = EPDM	1 = BSP	= zone 2	AB = STANDARD
	KC = PVDF+CF	MT = SANTOPRENE +PTFE	S = SS	K = PVDF	V = VITON	A = BSP with ring		
	A = ALU	H = HYTREL	D = EPDM	S = SS	N = NBR	2 = FLANGED		
	S = SS	W = SANTOPRENE H.R.	N = NBR	Z = PE-UHMWE	T = PTFE	5 = NPT E = NPT with ring		



PP



PVDF+CF



ALU



SS

TECHNICAL DATA

- Fluid connections 1/2" BSPP
- Air connection 1/4" BSPP
- Max flow rate 65 lt/min
- Max air pressure 8 bar
- Max delivery head 80 mt
- Max suction lift dry 5 mt
- Max suction lift wet 9,8 mt
- Max solid passing 3,5 mm
- Noise level 72 dB
- Max viscosity 20.000 cps
- Displacement per stroke 140 CC ~

Ⓢ II 3/3 G Ex h IIC T4 Gc
 Ⓢ II 3 D Ex h IIIB T135°C Dc X

Displacement per stroke may vary based on suction condition, discharge head, air pressure and fluid type.

PERFORMANCE

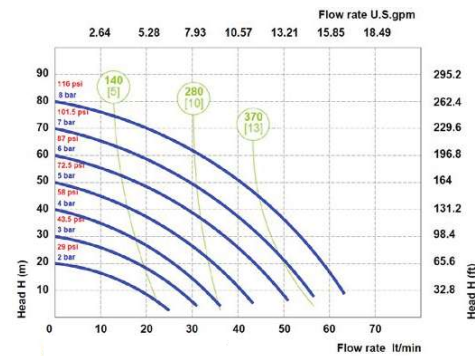

○ Air supply pressure

○ Air consumption NL/min [SCFM]

The curves and performance values refer to pumps with submerged suction and free delivery outlet, with water at 20°C. These data may vary according to the construction materials and hydraulic conditions.

DIMENSIONS

	A	B	C	Weight Kg	Temperature	
PP	238 mm	165 mm	249 mm	4,3 kg	- 4 °C	+ 65 °C
PVDF	238 mm	165 mm	249 mm	5,3 kg	- 20 °C	+ 95 °C
ALU	234 mm	165 mm	245 mm	4,3 kg	- 20 °C	+ 95 °C
SS	234 mm	165 mm	269 mm	7,3 kg	- 20 °C	+ 95 °C

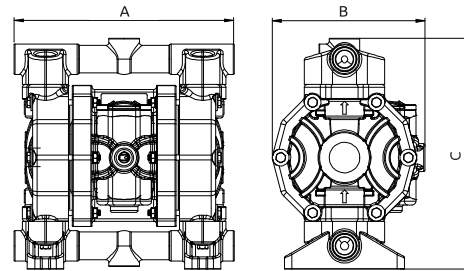

COMPOSITION

MODEL	CASING	DIAPHRAGM	BALLS	SEATS	GASKET	CONNECTIONS	ATEX	PORTS
AMP0060	P = PP	HT = HYTREL+PTFE	T = PTFE	P = PP	D = EPDM	1 = BSP	- = zone 2	AB = STANDARD
	KC = PVDF+CF	MT = SANTOPRENE +PTFE	S = SS	K = PVDF	V = VITON	A = BSP with ring		
	S = SS	H = HYTREL	D = EPDM	S = SS	N = NBR	2 = FLANGED		
	A = ALU	W = SANTOPRENE H.R. D = EPDM N = NBR	N = NBR	Z = PE-UHMWE	T = PTFE	5 = NPT E = NPT with ring		



PP



PVDF+CF



ALU



SS

TECHNICAL DATA

- Fluid connections **3/4" BSPP**
- Air connection **3/8" BSPP**
- Max flow rate **100 lt/min**
- Max air pressure **8 bar**
- Max delivery head **80 mt**
- Max suction lift dry **5 mt**
- Max suction lift wet **9,8 mt**
- Max solid passing **4 mm**
- Noise level **72 dB**
- Max viscosity **25.000 cps**
- Displacement per stroke **200 CC ~**

Ⓢ II 3/3 G Ex h IIC T4 Gc
 Ⓢ II 3 D Ex h IIIB T135°C Dc X

Displacement per stroke may vary based on suction condition, discharge head, air pressure and fluid type.

PERFORMANCE

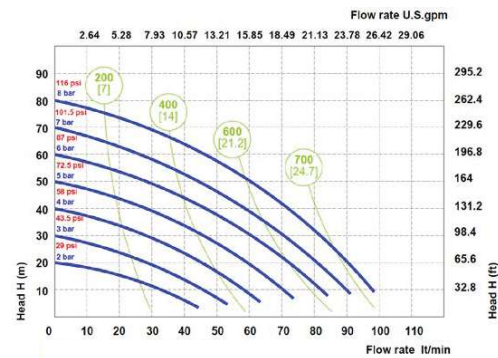

○ Air supply pressure

○ Air consumption Nl/min [SCFM]

The curves and performance values refer to pumps with submerged suction and free delivery outlet, with water at 20°C. These data may vary according to the construction materials and hydraulic conditions.

DIMENSIONS

	A	B	C	Weight Kg	Temperature	
PP	293 mm	179 mm	267 mm	5,1 kg	- 4 °C	+ 65 °C
PVDF	293 mm	179 mm	267 mm	6,6 kg	- 20 °C	+ 95 °C
ALU	293 mm	178 mm	290 mm	5,6 kg	- 20 °C	+ 95 °C
SS	280 mm	178 mm	291 mm	7,6 kg	- 20 °C	+ 95 °C

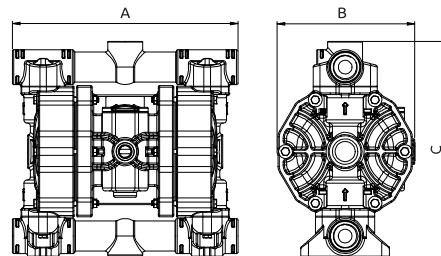

COMPOSITION

MODEL	CASING	DIAPHRAGM	BALLS	SEATS	GASKET	CONNECTIONS	ATEX	PORTS
AMP0090	P = PP	HT = HYTREL+PTFE	T = PTFE	P = PP	D = EPDM	1 = BSP	- = zone 2	AB = STANDARD
	KC = PVDF+CF	MT = SANTOPRENE +PTFE	S = SS	K = PVDF	V = VITON	A = BSP with ring		
	A = ALU	H = HYTREL	D = EPDM	S = SS	N = NBR	2 = FLANGED		
	S = SS	W = SANTOPRENE H.R.	N = NBR	Z = PE-UHMWE	T = PTFE	5 = NPT		
		D = EPDM				E = NPT with ring		
		N = NBR						



PP



PVDF+CF



ALU



SS

TECHNICAL DATA

- Fluid connections 1" BSPP
- Air connection 3/8" BSPP
- Max flow rate 120 lt/min
- Max air pressure 8 bar
- Max delivery head 80 mt
- Max suction lift dry 5 mt
- Max suction lift wet 9,8 mt
- Max solid passing 4 mm
- Noise level 72 dB
- Max viscosity 25.000 cps
- Displacement per stroke 200 CC ~

Ⓢ II 3/3 G Ex h IIC T4 Gc
 Ⓢ II 3 D Ex h IIIB T135°C Dc X

Displacement per stroke may vary based on suction condition, discharge head, air pressure and fluid type.

PERFORMANCE

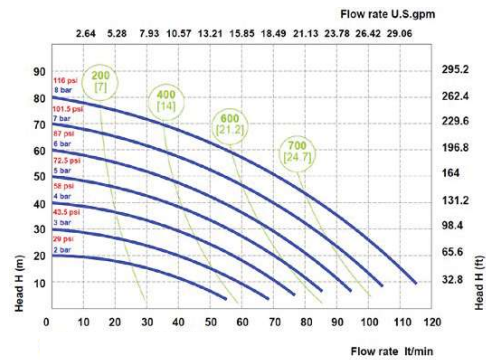

○ Air supply pressure

○ Air consumption Nl/min [SCFM]

The curves and performance values refer to pumps with submerged suction and free delivery outlet, with water at 20°C. These data may vary according to the construction materials and hydraulic conditions.

DIMENSIONS

	A	B	C	Weight Kg	Temperature	
PP	293 mm	179 mm	280 mm	5,6 kg	- 4 °C	+ 65 °C
PVDF	293 mm	179 mm	280 mm	7,6 kg	- 20 °C	+ 95 °C
ALU	293 mm	178 mm	301 mm	5,6 kg	- 20 °C	+ 95 °C
SS	280 mm	178 mm	291 mm	9,6 kg	- 20 °C	+ 95 °C

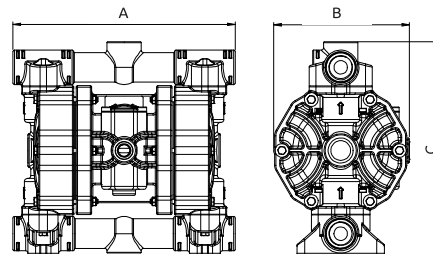

COMPOSITION

MODEL	CASING	DIAPHRAGM	BALLS	SEATS	GASKET	CONNECTIONS	ATEX	PORTS
AMP0120	P = PP	HT = HYTREL+PTFE	T = PTFE	P = PP	D = EPDM	1 = BSP	- = zone 2	AB = STANDARD
	KC = PVDF+CF	MT = SANTOPRENE +PTFE	S = SS	K = PVDF	V = VITON	A = BSP with ring		
	A = ALU	H = HYTREL	D = EPDM	S = SS	N = NBR	2 = FLANGED		
	S = SS	W = SANTOPRENE H.R.	N = NBR	Z = PE-UHMWE	T = PTFE	5 = NPT		
		D = EPDM				E = NPT with ring		
		N = NBR						

AMP SERIES

AMP 170



PP



PVDF+CF



ALU (P 160)



SS

TECHNICAL DATA

- Fluid connections 1" BSPP-DN25
- Air connection 1/2" BSPP
- Max flow rate 170 lt/min
- Max air pressure 8 bar
- Max delivery head 80 mt
- Max suction lift dry 5 mt
- Max suction lift wet 9,8 mt
- Max solid passing 7,5 mm
- Noise level 75 dB
- Max viscosity 35.000 cps
- Displacement per stroke 700 CC ~

Ⓜ II 3/3 G Ex h IIB T4 Gc
 Ⓜ II 3 D Ex h IIB T135°C Dc X

Displacement per stroke may vary based on suction condition, discharge head, air pressure and fluid type.

PERFORMANCE

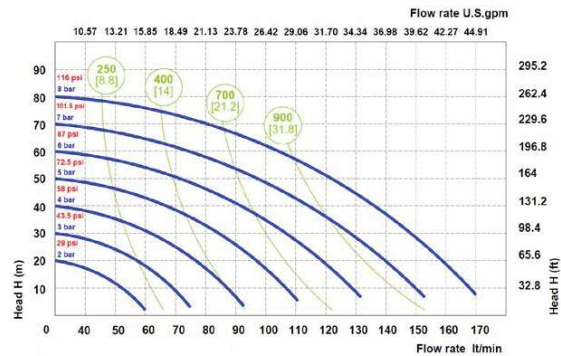

○ Air supply pressure
 ○ Air consumption Nlt/min [SCFM]

The curves and performance values refer to pumps with submerged suction and free delivery outlet, with water at 20°C. These data may vary according to the construction materials and hydraulic conditions.

DIMENSIONS

	A	B	C	Weight Kg	Temperature	
PP	430 mm	222 mm	414 mm	14,2 kg	- 4 °C	+ 65 °C
PVDF	430 mm	222 mm	414 mm	16,2 kg	- 20 °C	+ 95 °C
ALU	370 mm	222 mm	364 mm	13,2 kg	- 20 °C	+ 95 °C
SS	357 mm	222 mm	371 mm	17,2 kg	- 20 °C	+ 95 °C

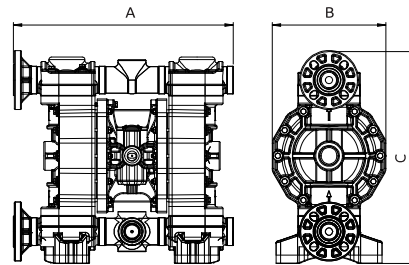

COMPOSITION

MODEL	CASING	DIAPHRAGM	BALLS	SEATS	GASKET	CONNECTIONS	ATEX	PORTS
AMP0170	P = PP	HT = HYTREL+PTFE	T = PTFE	P = PP	D = EPDM	1 = BSP	- = zone 2	AB = STANDARD
AMP0160 (ONLY ALU)	KC = PVDF+CF	MT = SANTOPRENE +PTFE	S = SS	K = PVDF	V = VITON	2 = FLANGED		
	A = ALU	H = HYTREL	D = EPDM	S = SS	N = NBR	5 = NPT		
	S = SS	W = SANTOPRENE H.R.	N = NBR	Z = PE-UHMWE	T = PTFE			
		D = EPDM						
		N = NBR						



PP



PVDF+CF



ALU (P 250)



SS

TECHNICAL DATA

- Fluid connections 1" 1/4" BSPP
- Air connection 1/2" BSPP
- Max flow rate 250 lt/min
- Max air pressure 8 bar
- Max delivery head 80 mt
- Max suction lift dry 5 mt
- Max suction lift wet 9,8 mt
- Max solid passing 7,5 mm
- Noise level 75 dB
- Max viscosity 35.000 cps
- Displacement per stroke 700 CC ~

⊗ II 3/3 G Ex h IIB T4 Gc
 ⊗ II 3 D Ex h IIB T135°C Dc X

Displacement per stroke may vary based on suction condition, discharge head, air pressure and fluid type.

PERFORMANCE

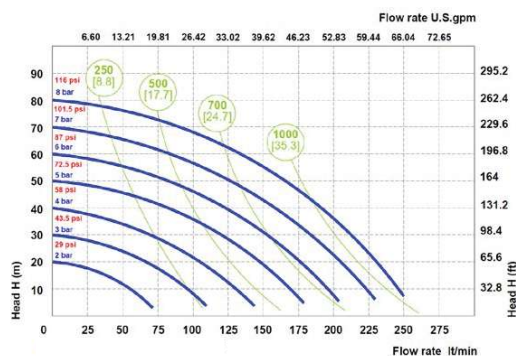

○ Air supply pressure
 ○ Air consumption NL/min [SCFM]

The curves and performance values refer to pumps with submerged suction and free delivery outlet, with water at 20°C. These data may vary according to the construction materials and hydraulic conditions.

DIMENSIONS

	A	B	C	Weight Kg	Temperature	
PP	396 mm	222 mm	388 mm	14,2 kg	- 4 °C	+ 65 °C
PVDF	396 mm	222 mm	388 mm	16,2 kg	- 20 °C	+ 95 °C
ALU	370 mm	222 mm	365 mm	13,2 kg	- 20 °C	+ 95 °C
SS	357 mm	222 mm	371 mm	17,2 kg	- 20 °C	+ 95 °C

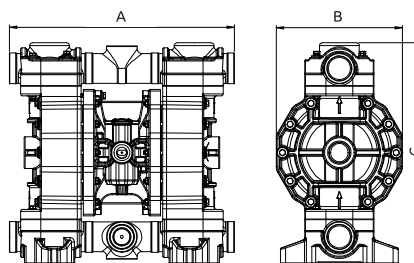

COMPOSITION

MODEL	CASING	DIAPHRAGM	BALLS	SEATS	GASKET	CONNECTIONS	ATEX	PORTS
AMP0252	P = PP	HT = HYTREL+PTFE	T = PTFE	P = PP	D = EPDM	1 = BSP	- = zone 2	AB = STANDARD
AMP0250 (ONLY ALU)	KC = PVDF+CF	MT = SANTOPRENE +PTFE	S = SS	K = PVDF	V = VITON	A = BSP with ring		
	A = ALU	H = HYTREL	D = EPDM	S = SS	N = NBR	2 = FLANGED		
	S = SS	W = SANTOPRENE H.R.	N = NBR	Z = PE-UHMWE	T = PTFE	5 = NPT		
		D = EPDM				E = NPT with ring		
		N = NBR						

AMP SERIES

AMP 400



PP



PVDF+CF



ALU



SS

TECHNICAL DATA

- Fluid connections 1" 1/2" BSPP-DN40
- Air connection 1/2" BSPP
- Max flow rate 380 lt/min
- Max air pressure 8 bar
- Max delivery head 80 mt
- Max suction lift dry 5 mt
- Max suction lift wet 9,8 mt
- Max solid passing 8 mm
- Noise level 78 dB
- Max viscosity 40.000 cps
- Displacement per stroke 1200 CC ~

Ⓜ II 3/3 G Ex h IIB T4 Gc
 Ⓜ II 3 D Ex h IIB T135°C Dc X

Displacement per stroke may vary based on suction condition, discharge head, air pressure and fluid type.

PERFORMANCE

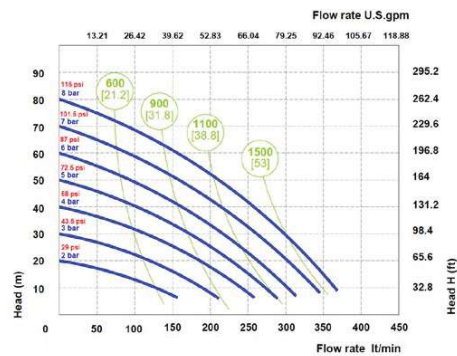

○ Air supply pressure

○ Air consumption Nlt/min [SCFM]

The curves and performance values refer to pumps with submerged suction and free delivery outlet, with water at 20°C. These data may vary according to the construction materials and hydraulic conditions.

DIMENSIONS

	A	B	C	Weight Kg	Temperature	
PP	454 mm	260 mm	564 mm	14,2 kg	- 4 °C	+ 65 °C
PVDF	454 mm	260 mm	564 mm	16,2 kg	- 20 °C	+ 95 °C
ALU	444 mm	260 mm	563 mm	13,2 kg	- 20 °C	+ 95 °C
SS	361 mm	260 mm	502 mm	17,2 kg	- 20 °C	+ 95 °C

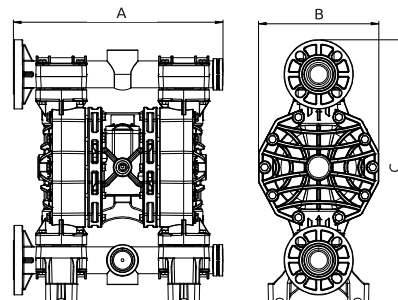

COMPOSITION

MODEL	CASING	DIAPHRAGM	BALLS	SEATS	GASKET	CONNECTIONS	ATEX	PORTS
AMP0400	P = PP	HT = HYTREL+PTFE	T = PTFE	P = PP	D = EPDM	1 = BSP	- = zone 2	AB = STANDARD EF = STANDARD SS
	KC = PVDF+CF	MT = SANTOPRENE +PTFE	S = SS	K = PVDF	V = VITON	2 = FLANGED		
	A = ALU	H = HYTREL	D = EPDM	S = SS	N = NBR	5 = NPT		
	S = SS	W = SANTOPRENE H.R.	N = NBR	Z = PE-UHMWE	T = PTFE			
		D = EPDM						
		N = NBR						



PP



PVDF+CF



ALU



SS

TECHNICAL DATA

- Fluid connections 2" BSPP-DN50
- Air connection 3/4" BSPP
- Max flow rate 700 lt/min
- Max air pressure 8 bar
- Max delivery head 80 mt
- Max suction lift dry 5 mt
- Max suction lift wet 9,8 mt
- Max solid passing 8,5 mm
- Noise level 78 dB
- Max viscosity 50.000 cps
- Displacement per stroke 3050 CC ~

Ⓢ II 3/3 G Ex h IIB T4 Gc
 Ⓢ II 3 D Ex h IIB T135°C Dc X

Displacement per stroke may vary based on suction condition, discharge head, air pressure and fluid type.

PERFORMANCE

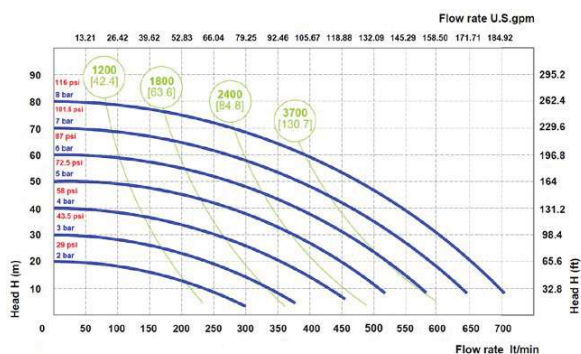

○ Air supply pressure
 ○ Air consumption Nlt/min [SCFM]

The curves and performance values refer to pumps with submerged suction and free delivery outlet, with water at 20°C. These data may vary according to the construction materials and hydraulic conditions.

DIMENSIONS

	A	B	C	Weight Kg	Temperature	
PP	595 mm	345 mm	570 mm	30,6 kg	- 4 °C	+ 65 °C
PVDF	595 mm	345 mm	570 mm	41,6 kg	- 20 °C	+ 95 °C
ALU	595 mm	340 mm	567 mm	37,6 kg	- 20 °C	+ 95 °C
SS	487 mm	340 mm	599 mm	51 kg	- 20 °C	+ 95 °C

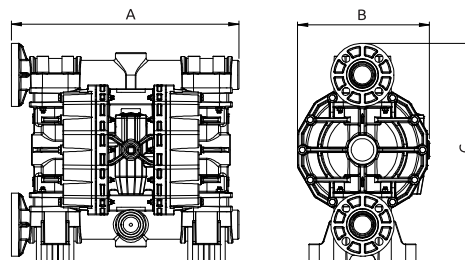

COMPOSITION

MODEL	CASING	DIAPHRAGM	BALLS	SEATS	GASKET	CONNECTIONS	ATEX	PORTS
AMP0700	P = PP	HT = HYTREL+PTFE	T = PTFE	P = PP	D = EPDM	1 = BSP	= zone 2	AB = STANDARD EF = STANDARD SS
	KC = PVDF+CF	MT = SANTOPRENE +PTFE	S = SS	K = PVDF	V = VITON	2 = FLANGED		
	A = ALU	H = HYTREL	D = EPDM	S = SS	N = NBR	5 = NPT		
	S = SS	W = SANTOPRENE H.R.	N = NBR	Z = PE-UHMWE	T = PTFE			
		D = EPDM						
		N = NBR						

AMP SERIES

AMP 1000



PP



PVDF+CF



ALU



SS

TECHNICAL DATA

- Fluid connections 3" BSPP-DN80
- Air connection 3/4" BSPP
- Max flow rate 1050 lt/min
- Max air pressure 8 bar
- Max delivery head 80 mt
- Max suction lift dry 5 mt
- Max suction lift wet 9,8 mt
- Max solid passing 12 mm
- Noise level 82 dB
- Max viscosity 55.000 cps
- Displacement per stroke 9750 CC ~

Ⓜ II 3/3 G Ex h IIB T4 Gc
 Ⓜ II 3 D Ex h IIB T135°C Dc X

Displacement per stroke may vary based on suction condition, discharge head, air pressure and fluid type.

PERFORMANCE

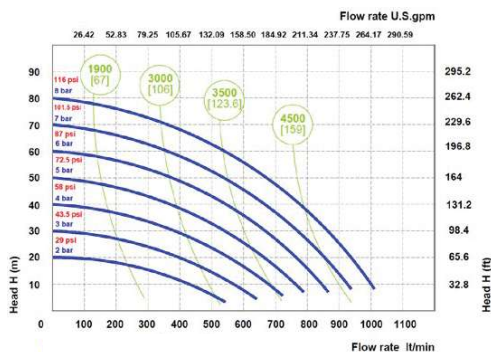

○ Air supply pressure
 ○ Air consumption Nlt/min [SCFM]

The curves and performance values refer to pumps with submerged suction and free delivery outlet, with water at 20°C. These data may vary according to the construction materials and hydraulic conditions.

DIMENSIONS

	A	B	C	Weight Kg	Temperature	
PP	780 mm	417 mm	1024 mm	62 kg	- 4 °C	+ 65 °C
PVDF	780 mm	417 mm	1024 mm	77 kg	- 20 °C	+ 95 °C
ALU	710 mm	417 mm	940 mm	84 kg	- 20 °C	+ 95 °C
SS	672 mm	417 mm	946,5 mm	122 kg	- 20 °C	+ 95 °C

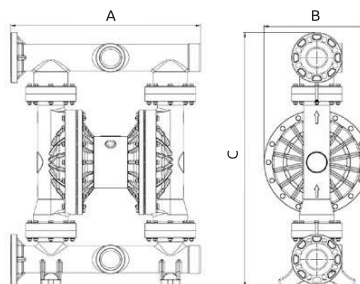

COMPOSITION

MODEL	CASING	DIAPHRAGM	BALLS	SEATS	GASKET	CONNECTIONS	ATEX	PORTS
AMP1000	P = PP	HT = HYTREL+PTFE	T = PTFE	P = PP	D = EPDM	1 = BSP	- = zone 2	AB = STANDARD
	KC = PVDF+CF	MT = SANTOPRENE +PTFE	S = SS	K = PVDF	V = VITON	2 = FLANGED		
	A = ALU	H = HYTREL	D = EPDM	S = SS	N = NBR	5 = NPT		
	S = SS	W = SANTOPRENE H.R.	N = NBR	Z = PE-UHMWE	T = PTFE			
		D = EPDM						
		N = NBR						