

# AODD PUMPS

[www.acmepompe.it](http://www.acmepompe.it)

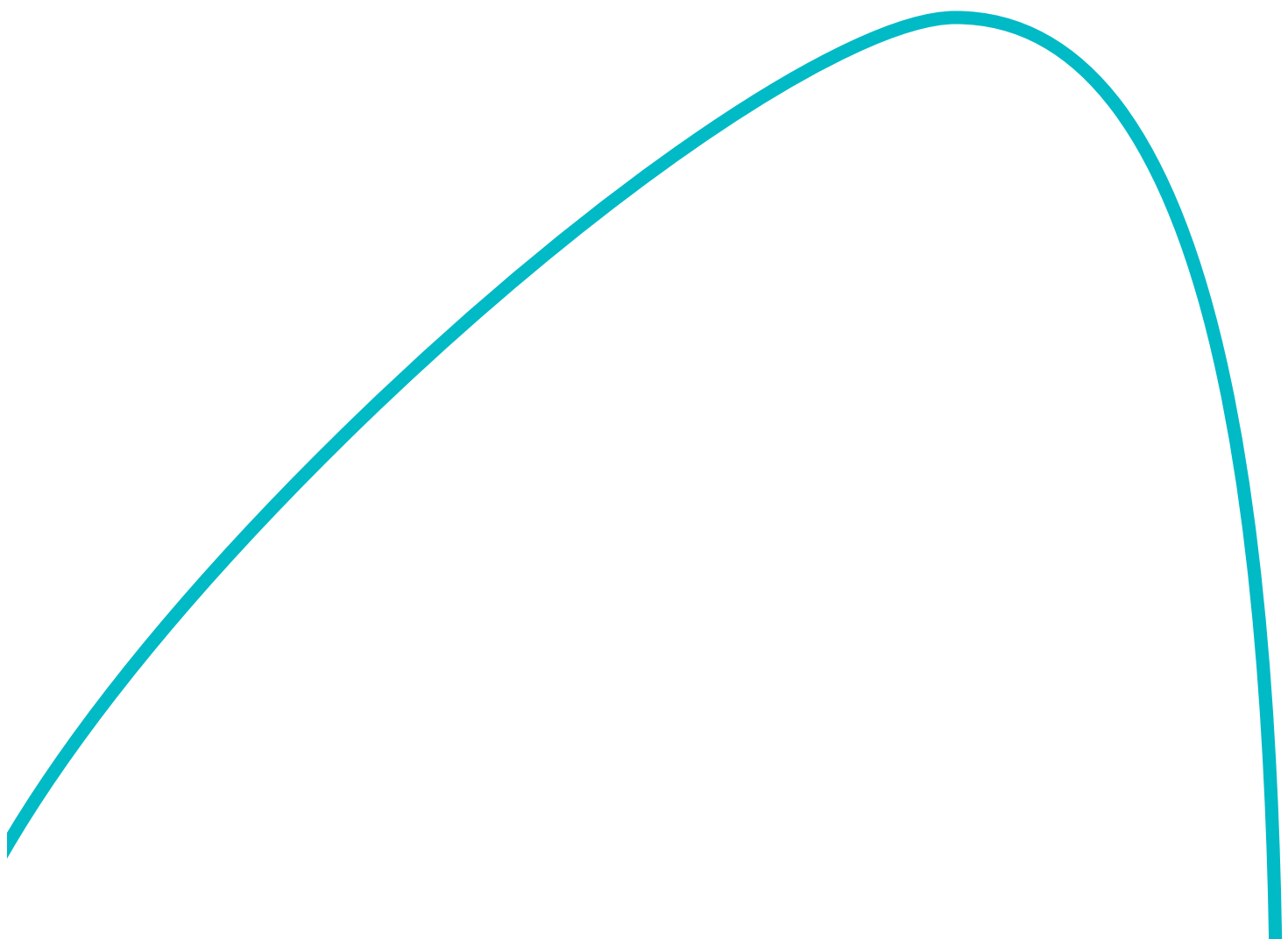



## INDEX

---

### **ACME**

Our company

**4**

---

### **Air-operated double-diaphragm pumps**

Operation, Installation, Technical data sheet

**7**

---

### **AMP pneumatic pumps**

AMP 4, AMP 8, AMP 20, AMP35, AMP 55, AMP 60, AMP 90, AMP 120,  
AMP 170, AMP 252, AMP 400, AMP 700, AMP 1000

**13**

---

### **AMP Food pneumatic pumps**

AMPF 20, AMPF 35, AMPF 60, AMPF 120, AMPF 170, AMPF 400,  
AMPF 700, AMPF 1000

**27**

---

### **AMP special pneumatic pumps**

AMP Atex, Accurate AMP, Flap AMP, Steel AMP,  
Drum AMP, Twin AMP, Submersible AMP, Power AMP

**33**

---

### **Damper**

Pulsation dampers

**39**

---

### **AML pneumatic pumps**

AML 10, AML 15, AML 25, AML 40

**43**

---

### **Accessories**

**51**

---

# ACME – CLEVER PUMPS INNOVATIVE SOLUTIONS FOR FLUID TRANSFER AND DOSING SINCE 1992

Founded in 1992, ACME Pumps quickly established itself as one of the leading manufacturers of industrial peristaltic pumps, air-operated double diaphragm pumps, centrifugal pumps and diaphragm metering pumps. With decades of experience supporting businesses across various sectors, our mission is to deliver highly specialized, tailor-made pumping solutions, solving complex challenges and meeting the unique needs of every customer.

## Headquarters and Production Facility

ACME's headquarters and manufacturing facility are located in Santo Stefano Ticino, just 25 km west of Milan and 30 km south of Malpensa Airport (MXP). This strategic location allows us to efficiently serve both national and international clients, offering excellent logistical connections for shipments and customer support. Our facility houses both the production plant and the commercial offices, enabling close coordination between our technical and sales teams to ensure fast, customized service.

## A Dynamic, Customer-Focused Company

ACME is a lean and flexible organization, able to adapt swiftly to market demands. Our customer-centric approach is reflected in our unique ability to respond to specific and customized requests. Thanks to our strong design expertise and long-standing partnerships with trusted suppliers, we can handle demand surges and provide prompt, reliable solutions—even through well-established subcontracting agreements.

## High-Quality Products for Every Industrial Sector

ACME offers a wide range of AODD pumps, ideal for dosing and transferring fluids in a variety of industrial applications. Sizes range from 1/4" to 3", with flow rates between 1 and 1,050 L/min. Flow is adjustable on all models simply by regulating the air inlet pressure and flow. Thanks to FDA and ATEX certifications, our pumps are fully qualified to operate in the food and pharmaceutical industries, as well as in any environments classified as potentially explosive.

ACME pumps are used across a wide range of industries, including:

- Water purification, wastewater treatment, aquariums, marine and naval sectors
- Chemical, pharmaceutical, and cosmetics industries
- Winemaking, food, and dairy sectors
- Paints, inks, paper mills, and tanneries
- Construction, cement and ceramic plants
- Oil & Gas sector, refineries, and fuel storage facilities.

Thanks to their durability and versatility, our pumps are ideal for transferring and dosing challenging fluids such as corrosive, abrasive, viscous liquids, or those with solid suspensions. They are designed to handle intermittent flow, difficult suction conditions, and can run dry for extended periods.

## Our Mission and Commitment to Quality

Our mission is clear: to deliver specific, customized pumping solutions with the customer always at the center. To ensure maximum reliability, we are constantly improving our products and manufacturing processes. Quality is our hallmark, achieved through:

- Long-standing collaborations with trusted suppliers





- Careful selection of materials and components
- Strict control over the entire production process
- Specialized expertise within our team

### A Leading International Brand

Driven by the professionalism and passion of our team, ACME has grown steadily over the years, strengthening its presence both in the local and international markets. Today, we are recognized as one of the key players in the pump sector, and we continue to expand our reach to meet the needs of an increasingly demanding market.

### Our Product Range

Our range of pumps includes:

- **Peristaltic pumps** – ideal for dosing and transferring viscous fluids with solid particles
- **Double diaphragm pneumatic pumps** – suitable for aggressive industrial fluids
- **Diaphragm dosing pumps** – designed for applications requiring precise dosing

- **Mag-drive and mechanically sealed centrifugal pumps** – for pulse-free transfer of low-viscosity fluids
- **Drum and IBC transfer pumps** – designed for direct liquid transfer from drums or IBC tanks

### Core Values

At the heart of our corporate philosophy lies the customer and a strong commitment to compliance and ethical standards. Every member of our internal and external teams is dedicated to providing solutions that are competent, reliable, and timely.

### Conclusion

For over 30 years, ACME Clever Pumps has stood for quality, innovation, and reliability in the industrial pump industry. Backed by decades of experience and a drive for continuous innovation, we are ready to support every customer—facing today's challenges and shaping tomorrow's solutions together.









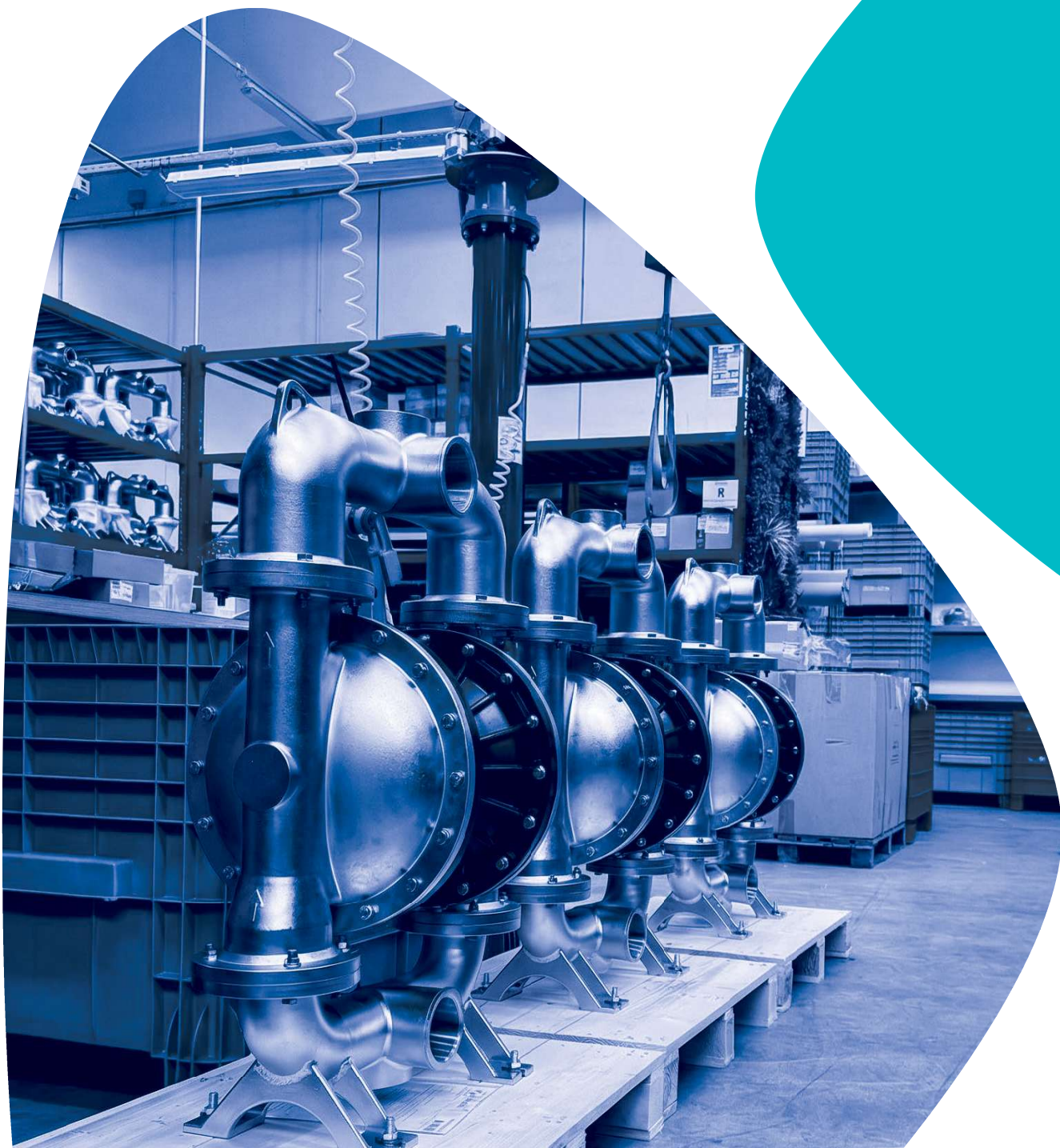







































# AIR-OPERATED DOUBLE-DIAPHRAGM PUMPS

Flow-rate from 4 lt/min to 1.050 lt/min.  
Special versions available



# IDENTIFICATION CODES TABLE

AMP	0120	P-	HT	T
MODEL	SIZE	CASING	DIAPHRAGMS	BALLS
<b>AMP</b> AMP 	<b>4</b> 4 lt/min 1/4" BSPP	 <b>P</b> POLYPROPYLENE Wide chemical compatibility. General usage. Reinforced with fiberglass.	 <b>H</b> HYTREL Good resistance to low temperatures and abrasion.	<b>N</b> NBR Suitable for petroleum-based fluids, water, oils, hydrocarbons and mild chemicals.
<b>AMPF</b> AMP FOOD 	<b>8</b> 7 lt/min 1/4" BSPP	 <b>PC</b> CONDUCTIVE POLYPROPYLENE Wide chemical compatibility. General usage. ATEX-compliant.	 <b>W</b> SANTOPRENE HIGH RESISTANCE Solutions and diluted acids.	 <b>D</b> EPDM Suitable for alkaline solutions, diluted acids, ketones and alcohols. Good abrasion resistance.
<b>AMAP</b> ACCURATE AMP 	<b>20</b> 20 lt/min 3/8" BSPP	 <b>KC</b> CONDUCTIVE PVDF Strong chemical resistance to acids and high temperatures. ATEX-compliant.	 <b>NBR</b> NBR Suitable for petroleum-based fluids, water, oils, hydrocarbons and mild chemicals.	 <b>T</b> PTFE Wide chemical compatibility, extreme corrosion resistance, anti-adhesive properties, and high heat resistance.
<b>AMTP</b> TWIN AMP 	<b>35</b> 35 lt/min 1/2" BSPP	 <b>O</b> ACETAL Resistant to a wide range of solvents and hydrocarbons. Good abrasion resistance. (available only in sizes 4, 8 and 10).	 <b>D</b> EPDM Suitable for alkaline solutions, diluted acids, ketones and alcohols. Good abrasion resistance.	 <b>S</b> SS Excellent resistance to corrosion and abrasion. Suitable for viscous fluids.
<b>AMPP</b> POWDER AMP 	<b>60</b> 65 lt/min 1/2" BSPP	 <b>OC</b> CONDUCTIVE ACETAL Resistant to a wide range of solvents and hydrocarbons. Good abrasion resistance. (available only in sizes 4, 8 and 10). ATEX-compliant.	 <b>HT</b> HYTREL + PTFE Wide chemical compatibility, extreme corrosion resistance, anti-adhesive properties, and high heat resistance.	 <b>MT</b> SANTOPRENE + PTFE Suitable for alkaline solutions, diluted acids, ketones and alcohols. Good abrasion resistance.
<b>AMPS</b> SUBMERSIBLE AMP 	<b>90</b> 100 lt/min 3/4" BSPP	 <b>A</b> ALUMINUM Resistant to a wide range of solvents and hydrocarbons. Good abrasion resistance.	 <b>SS</b> ELECTROPOLISHED Excellent resistance to corrosion and abrasion. Food version available.	
<b>AMDP</b> DRUM AMP 	<b>120</b> 120 lt/min 1" BSPP			
<b>AMFP</b> FLAP AMP 	<b>170</b> 170 lt/min 1" BSPP/DN25			
	<b>252</b> 250 lt/min 1" 1/4 BSPP			
	<b>400</b> 380 lt/min 1" 1/2 BSPP DN40			
	<b>700</b> 700 lt/min 2" BSPP DN50			
	<b>1000</b> 1050 lt/min 3" BSPP DN80			

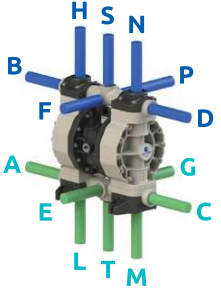
P	V	1	-	AB
BALL SEATS	GASKETS	CONNECTIONS	ATEX ZONE CERTIFICATION	PORTS
<p><b>P</b> POLYPROPYLENE Wide chemical compatibility. General usage.</p>  <p><b>K</b> PVDF Strong chemical resistance to acids and high temperatures.</p>  <p><b>S</b> SS Excellent resistance to corrosion and abrasion.</p>  <p><b>Z</b> PE Suitable for fluids with high molecular weight. High abrasion resistance. (available only with D and N balls).</p>  <p><b>O</b> ACETAL Resistant to a wide range of solvents and hydrocarbons. Good abrasion resistance.</p> 	<p><b>V</b> VITON High heat resistance. Good resistance to aggressive chemicals and hydrocarbons.</p>  <p><b>N</b> NBR Suitable for petroleum-based fluids, water, oils, hydrocarbons and mild chemicals.</p>  <p><b>D</b> EPDM Suitable for alkaline solutions, diluted acids, ketones and alcohols. Good abrasion resistance.</p>  <p><b>T</b> PTFE Wide chemical compatibility, extreme corrosion resistance, anti-adhesive properties, and high heat resistance.</p> 	<p><b>1</b> BSP THREADED</p> <p><b>A</b> BSP THREADED WITH REINFORCED RING</p> <p><b>2</b> FLANGED</p> <p><b>3</b> TRI-CLAMP (AMP FOOD)</p> <p><b>5</b> NPT THREADED</p> <p><b>E</b> NPT THREADED WITH REINFORCED RING</p> <p><b>6</b> DIN 11851/3 (AMP FOOD)</p>	<p></p> <p>- ATEX ZONE 2 From P4 to P120 models   II 3/3 G Ex h IIC T4 Gc   II 3 D Ex h IIIB T135°C Dc X</p> <p>From P170 to P1000 models   II 3/3 G Ex h IIB T4 Gc   II 3 D Ex h IIIB T135°C Dc X</p> <p><b>X</b> ATEX ZONE 1 From P4 to P120 models   III 2/2 G Ex h IIC T4 Gb   II 2 D Ex h IIIB T135°C Db X</p> <p>From P170 to P1000 models   II 2/2 G Ex h IIB T4 Gb   II 2 D Ex h IIIB T135°C Db X</p>	
<p><b>SPECIAL FEATURES</b></p> <p><b>AMSP</b> STAINSTEEL AMP central block made of stainless steel</p> <p><b>AMSCP</b> STROKE COUNTER AMP with external pneumatic signal</p> <p><b>AMPCR</b> AMP with shorter strokes</p> <p><b>AMPCL</b> AMP with longer strokes</p>				

# PUMP OPERATION



◆ Fluid    ◆ Air

## 1 - SUCTION CYCLE

Compressed air fills the right inner chamber. The movement of the opposing diaphragm lifts the lower valve ball, creating suction and drawing fluid through the inlet. At the same time, the left chamber is in the "Discharge" cycle.

## 2 - DISCHARGE CYCLE

Compressed air fills the left inner chamber. The opposing chamber, by lifting the upper valve, discharges fluid. At the same time, the right chamber is in the "suction" cycle.

# INSTALLATION



### Pump installed below head (positive suction)

Used when the tank must be completely emptied



### Self-priming pump installed above head (negative suction)

Easily handles initial dry suction



### Pump installed above drum or tank

Special-feature pump

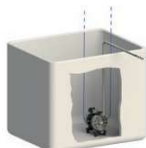

### Submerged pump

Chemical compatibility must be verified



### Pump installed on hopper for high viscosity fluids

The hopper's height helps the pump in moving the fluid. Air pressure has to be high, and a suction tube needs to be bigger than the pump's size



### Suspended

Special version for ceiling fixing that comes with additional feet in the upper part



### Pump installed on a mobile unit

The trolley or cart facilitates easy handling of the pump

# TECHNICAL DATA SHEET

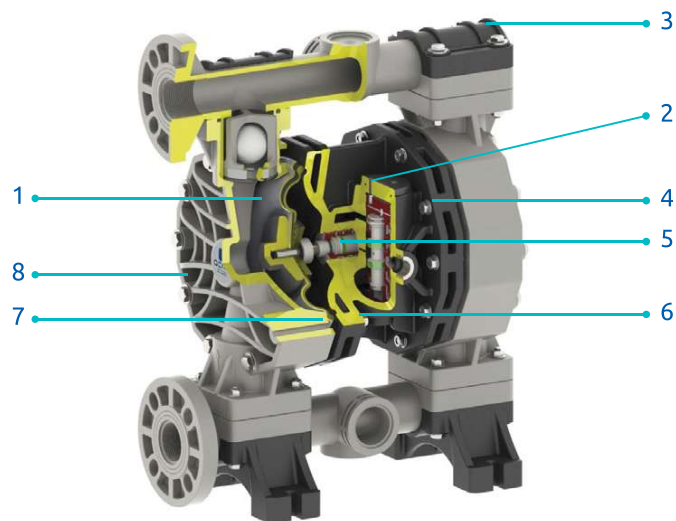

- 1** Long-lasting diaphragms that ensure a consistent performance and longer operating life.
- 2** Efficient design of the pneumatic exchanger ensures low air consumption. An unbalanced pilot spool precisely controls the positioning of the main power spool, eliminating stalling and increasing efficiency.
- 3** All-bolted design ensures effective sealing and maximum safety.
- 4** Solid polypropylene air chambers and plastic air valve ensure maximum chemical resistance in highly corrosive environments.
- 5** Acetal pneumatic exchanger and bushings provide long-lasting resistance thanks to self-lubrication.
- 6** The pneumatic exchanger is easily accessible from the outside for quick inspection. The air system is lube-free, antistall and antifreeze.
- 7** Special diaphragm clamping, designed to minimize wear and increase service life, while providing a secure, hermetic and leak-proof seal.
- 8** Exhaust chamber with double silencer designed to enhance diffusion passages, reduce freezing, and ensure low noise levels.

- ◆ Wide range of flow rates and materials suitable for various conditions and fluids
- ◆ Safe "dead head" operation: with a closed discharge the pump will not be damaged
- ◆ Suitable for handling of liquids containing solids particles
- ◆ Fully submersible: can be entirely immersed, depending on fluid compatibility
- ◆ Serviceability: easily and quickly maintained with no special tools required
- ◆ High performance thanks to an optimal and functional design
- ◆ Self-priming: capable of dry suction up to 6 meters
- ◆ Seal-less design: dry-run without damaging the pumping system

**QUALITY** 100% of the pumps are tested with water after final assembly

**SAFETY** ATEX certification on all versions: conductive plastic pumps available

**FLEXIBILITY** Multiple porting options and connection types available



# PUMP SELECTION

To select the appropriate pump model based on the intended application, the following factors should be considered in order to optimize performance, extend service life, and minimize maintenance costs:

- The nature of the fluid to be pumped, its viscosity, and the solids particles it may contain;
- The pump capacity in relation to the required flow rate;
- Suction and discharge (head) conditions;

Taking these parameters into account, the correct pump is selected when the intersection of the “head” and “flow rate” axes on the performance curve is near the center section of the graph.

## PERFORMANCE CURVES

To determine the compressed air requirements and the proper size for a ACME AODD pump, two pieces of information are necessary:

- 1 Required flow rate
- 2 Total delivery head

For example, consider the P170 pump performance curve, which has a pumping capacity of approximately 135 l/min at 25m. Point A on the performance curve is the intersection between the required flow rate and the total delivery head, and it determines the compressed air requirements for this pump. At point A, the pump will require approximately 7 bar of air inlet pressure for proper operation. To verify this, follow the blue curve on the left to read the air pressure in BAR. Then, by following the nearest green curve, it can be seen that the pump will require approximately 900 nl/min (Normal Liter per minute) of air consumption.

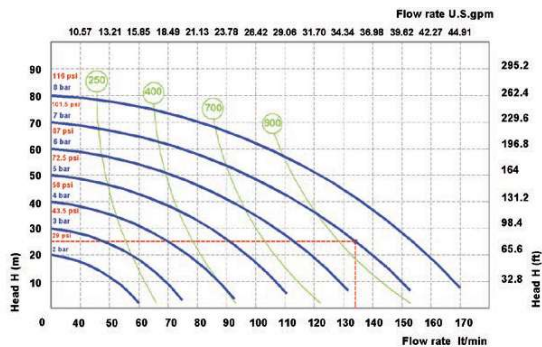

## SPECIFIED SUCTION LIFT

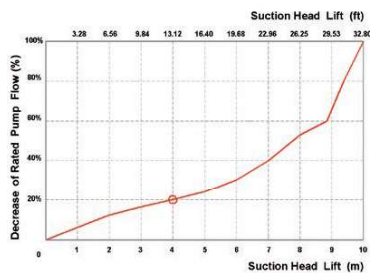

With a suction lift of 4 m, the pump’s flow rate decreases by approximately 20%. This applies to pumps of 3/4” and larger; data varies depending on the pump configuration.

## VISCOUS LIQUIDS PERFORMANCE DATA

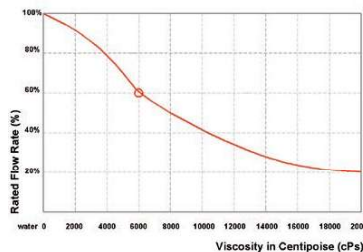

When pumping a fluid with a viscosity of 6000 cps, the pump’s flow rate decreases by 60% of its rated value (100% = water). This applies to pumps of 3/4” and larger.

Pump Type	AODD	Centrifugal	Lobe	Gear	Screw	Peristaltic	Piston
Variable Flow & Head Control	◆	◆	◆	◆	◆	◆	◆
Deadhead Safety	◆	◆	◆	◆	◆	◆	◆
Dry-Running	◆	◇	◇	◇	◇	◆	◇
Dry Self-Priming	◆	◇	◇	◆	◇	◆	◆
No Mechanical Alignment	◆	◇	◇	◇	◇	◇	◇
No Electrical Installation	◆	◇	◇	◇	◇	◇	◇
Portability	◆	◆	◆	◆	◆	◆	◆
Submersible	◆	◆	◇	◇	◇	◇	◆
Sealless	◆	◆	◆	◆	◆	◆	◆
Cavitation Tolerance	◆	◇	◆	◆	◆	◆	◆
Low Shear & Degradation	◆	◇	◆	◆	◆	◆	◆

◆ = Suitable   ◆ = With limitations   ◇ = Not recommended

# AML PNEUMATIC PUMPS

Pure double diaphragm pneumatic pumps  
Flow-rate from 10 lt/min to 290 lt/min.



# TABLE CODES

L	0015	T-	DT	T
MODEL	SIZE	CASING	DIAPHRAGM	BALL
<b>AML</b> AML Standard central block in POLYETHYLENE, available, on request, in PTFE. 	<b>10</b> 10 lt/min 3/8" BSPP	 <b>T</b> PTFE Widest chemical compatibility, extreme corrosion resistance, non-adhesive, high heat resistance.	<b>DT</b> EPDM+PTFE Widest chemical compatibility, extreme corrosion resistance, non-adhesive, high heat resistance.	<b>T</b> PTFE Widest chemical compatibility, extreme corrosion resistance, non-adhesive, high heat resistance.
	<b>15</b> 55 lt/min 1/2" BSPP	 <b>TC</b> CONDUCTIVE PTFE Widest chemical compatibility, extreme corrosion resistance, non-adhesive, high heat resistance. Ground able.		
	<b>25</b> 110 lt/min 1" BSPP	 <b>Z</b> PE With high molecular weight: High level of abrasion resistance.	<b>D</b> EPDM OK with caustic solutions, dilute acids, ketones and alcohols. Good abrasion resistance.	<b>S</b> SS High level of corrosion and abrasion resistance. Good for viscous fluids
	<b>40</b> 290 lt/min 1" 1/2 BSPP	 <b>ZC</b> CONDUCTIVE PE With high molecular weight: High level of abrasion resistance. Ground able.		
	 <b>PP</b> PURE Wide chemical compatibility. General purpose.		<b>D</b> EPDM OK with caustic solutions, dilute acids, ketones and alcohols. Good abrasion resistance.	

## PUMP OPERATION

-  Fluid
-  Air

### 1 - SUCTION CYCLE



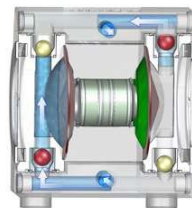



Compressed air fills right inner chamber, causing the opposing diaphragm to create suction, lifting the lower valve ball, pulling in fluid at inlet. Simultaneously, the right chamber is in "Discharge" cycle.

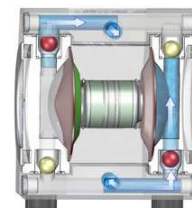

### 2 - DISCHARGE CYCLE

Compressed air fills left inner chamber, causing upper valve ball to open and discharge fluid. Simultaneously, the right chamber is in "Suction" cycle.

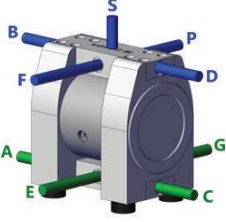

T	T	1	-	EF
BALL SEAT	GASKET	CONNECTIONS	ATEX ZONE CERTIFICATION	PORTS
<p><b>T</b> PTFE Widest chemical compatibility, extreme corrosion resistance, non-adhesive, high heat resistance.</p>  <p><b>Z</b> PE With high molecular weight: High level of abrasion resistance.</p>  <p><b>PP</b> PURE POLYPROPYLENE Wide chemical compatibility. General purpose.</p> 	<p><b>T</b> PTFE Widest chemical compatibility, extreme corrosion resistance, non-adhesive, high heat resistance.</p>  <p><b>F</b> FEP-FKM With high molecular weight: High level of abrasion resistance.</p>  <p><b>D</b> EPDM Good with caustic solutions, dilute acids, ketones and alcohols. Good abrasion resistance.</p> 	<p><b>1</b> BSP THREADED</p> <p><b>2</b> FLANGED</p> <p><b>5</b> NPT THREADED</p>	<p><b>Ex</b></p> <p><b>- ATEX ZONE 2</b> L10 and L15 models            Ⓢ II 3/3 G Ex h IIC T4 Gc            Ⓢ II 3 D Ex h IIIB T135°C Dc X</p> <p>L25 and L40 models            Ⓢ II 3/3 G Ex h IIB T4 Gc            Ⓢ II 3 D Ex h IIIB T135°C Dc X</p> <p><b>X ATEX ZONE 1</b> L10 and L15 models            Ⓢ III 2/2 G Ex h IIC T4 Gb            Ⓢ II 2 D Ex h IIIB T135°C Db X</p> <p>L25 and L40 models            Ⓢ II 2/2 G Ex h IIB T4 Gb            Ⓢ II 2 D Ex h IIIB T135°C Db X</p>	
<p><b>SPECIAL FEATURES</b> AMTL CENTRAL BLOCK IN PTFE</p>				

## INSTALLATION



**Pump installed below head (positive suction)**  
when it is necessary to empty completely the container



**Pump installed above drum or tank**  
with special featuring pump



**Pump installed on a mobile unit**  
with a trolley or cart when pump must be often moved



**Self-priming pump installed above head (negative suction)**  
pump initially works with dry column without problem



**Chemical System**  
pumps are suitable to be integrated in dosing systems for concentrated acids at high temperature

# TECHNICAL FEATURES

---

The materials of construction of the AML series are PTFE, CONDUCTIVE PTFE, PE, CONDUCTIVE PE and PURE POLYPROPYLENE. The AML pumps are suitable to work with hazardous chemicals such as acids, caustics, and solvents.

---

## FEATURES AND BENEFITS

- Machined plastic design
- Increased capacity
- Increased safety
- Decreased air consumption
- Easy cleanability
- Reduced noise level
- Decreased downtime
- Optimized flow pattern
- Increased quality
- Long service life
- Increased reliability
- Used in demanding process applications
- Robust plastic design with reinforcement ring for enhanced sealing and torque retention



## APPLICATIONS

- Abrasive Slurries
- Solar Cell
- Biopharmaceutical
- Chemicals
- Etching Agents
- Ceramic
- Sludge Transfer
- Glazes Transfer
- Paints
- Varnish
- High Concentrated Acids and Bases
- Grinding and Drilling Emulsions
- Paper and Printing
- Glue Transport
- Printing Inks Transport
- Industrial Water Treatment
- Sample Analysis
- Wastewater Neutralization
- Feeding Filter Presses with Sludge
- Chemical Treatment of Wafers
- Corrosive, Hazardous or Toxic Chemicals

---

### Machined for Precision

ACME's solid plastic block increases the pump's strength and life cycle while eliminating many maintenance concerns. The AML Series CNC machined solid block of PTFE, PE or PP allows to deal with the harshest environments. The AML Series solid plastic block construction is mechanically machined rather than injection moulded. The CNC technology enables tight tolerances, along with reduced vibration, less risk of leakage, and greater stability and durability. The high static mass leads to smooth operation with reduced vibration.



## TECHNICAL DATA

- Fluid connections **3/8" BSP**
- Air connection **1/4" BSP**
- Max. Flow rate **24 lt/min**
- Max air pressure **7 bar**
- Max delivery head **70 mt**
- Max Suction Lift Dry **4 mt**
- Max Suction Lift Wet **9,8 mt**
- Max Solid passing **3 mm**
- Noise level **65 dB**
- Max Viscosity **15.000 cps**
- Displacement per Stroke **65 CC ~**

Ⓢ II 3/3 G Ex h IIC T4 Gb  
 Ⓢ II 3 D Ex h IIIB T135°C Db X

Displacement per stroke may vary based on suction condition, discharge head, air pressure and fluid type.

## PERFORMANCE

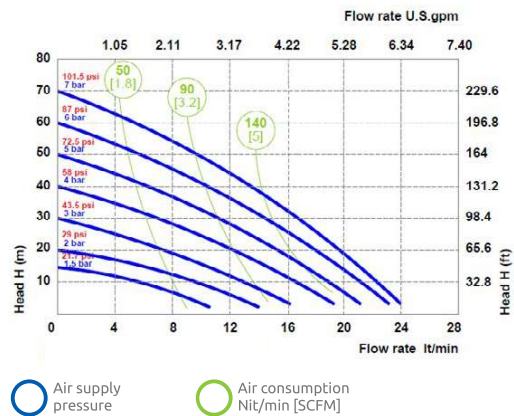

The curves and performance values refer to pumps with submerged suction and a free delivery outlet with water at 20°C. These data may vary according to the construction materials and hydraulic conditions.

## DIMENSIONS

	A	B	C	Weight Kg	Temperature	
<b>PTFE</b>	157 mm	110 mm	180 mm	5 kg	-20 °C	+120 °C
<b>PTFE+CF</b>	157 mm	110 mm	180 mm	5 kg	-20 °C	+120 °C
<b>PE</b>	157 mm	110 mm	180 mm	2,5 kg	-4 °C	+65 °C
<b>PE+CF</b>	157 mm	110 mm	180 mm	2,5 kg	-4 °C	+65 °C
<b>PP</b>	157 mm	110 mm	180 mm	2,5 kg	-4 °C	+65 °C

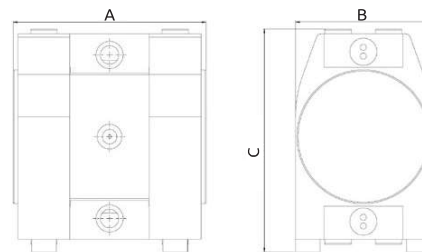

## COMPOSITION

MODEL	CASING	DIAPHRAGM	BALLS	SEATS	GASKET	CONNECTIONS	ATEX	PORTS
<b>AML010</b>	T = PTFE	DT = EPDM+PTFE	T = PTFE	T = PTFE	T = PTFE	1 = BSP	- = zone 2	EF = STANDARD
	TC = PTFE+CF	D = EPDM	S = SS	Z = PE	F = FEP+FKM	2 = FLANGED	X = zone 2	
	Z = PE		D = EPDM	PP = PURE PP	D = EPDM	5 = NPT		
	ZC = PE+CF							
	PP = PURE PP							

Central block in POLYETHYLENE, available, on request, in PTFE





## TECHNICAL DATA

- Fluid connections **1/2" BSP**
- Air connection **1/4" BSP**
- Max. Flow rate **55 lt/min**
- Max air pressure **8 bar**
- Max delivery head **80 mt**
- Max Suction Lift Dry **4 mt**
- Max Suction Lift Wet **9,8 mt**
- Max Solid passing **3,5 mm**
- Noise level **70 dB**
- Max Viscosity **20.000 cps**
- Displacement per Stroke **140 CC ~**

Ⓢ II 3/3 G Ex h IIC T4 Gb  
 Ⓢ II 3 D Ex h IIIB T135°C Db X

Displacement per stroke may vary based on suction condition, discharge head, air pressure and fluid type.

## PERFORMANCE



The curves and performance values refer to pumps with submerged suction and a free delivery outlet with water at 20°C. These data may vary according to the construction materials and hydraulic conditions.

## DIMENSIONS

	A	B	C	Weight Kg	Temperature	
<b>PTFE</b>	226 mm	160 mm	260 mm	14 kg	-20 °C	+95 °C
<b>PTFE+CF</b>	226 mm	160 mm	260 mm	14 kg	-20 °C	+95 °C
<b>PE</b>	226 mm	160 mm	260 mm	6,7 kg	-4 °C	+65 °C
<b>PE+CF</b>	226 mm	160 mm	260 mm	6,7 kg	-4 °C	+65 °C
<b>PP</b>	226 mm	160 mm	260 mm	6,7 kg	-4 °C	+65 °C

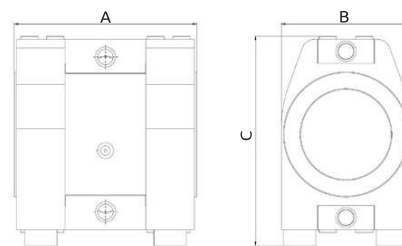

## COMPOSITION

MODEL	CASING	DIAPHRAGM	BALLS	SEATS	GASKET	CONNECTIONS	ATEX	PORTS
<b>AML015</b>	T = PTFE	DT = EPDM+PTFE	T = PTFE	T = PTFE	T = PTFE	1 = BSP	= zone 2	EF = STANDARD
	TC = PTFE+CF	D = EPDM	S = SS	Z = PE	F = FEP+FKM	2 = FLANGED	X = zone 2	
	Z = PE		D = EPDM	PP = PURE PP	D = EPDM	5 = NPT		
	ZC = PE+CF							
	PP = PURE PP							

Central block in POLYETHYLENE, available, on request, in PTFE



## TECHNICAL DATA

- Fluid connections **1" BSP**
- Air connection **1/2" BSP**
- Max. Flow rate **110 lt/min**
- Max air pressure **8 bar**
- Max delivery head **80 mt**
- Max Suction Lift Dry **5 mt**
- Max Suction Lift Wet **9,8 mt**
- Max Solid passing **4 mm**
- Noise level **72 dB**
- Max Viscosity **25.000 cps**
- Displacement per Stroke **200 CC ~**

Ⓢ II 3/3 G Ex h IIB T4 Gb  
 Ⓢ II 3 D Ex h IIIB T135°C Db X

Displacement per stroke may vary based on suction condition, discharge head, air pressure and fluid type.

## PERFORMANCE

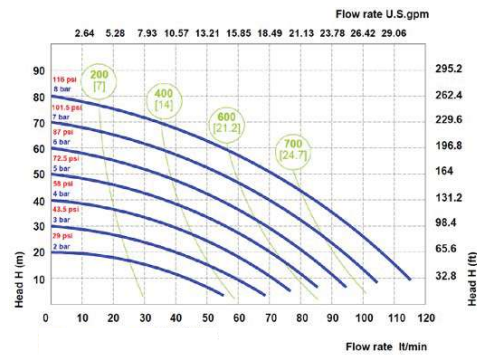

○ Air supply pressure  
 ○ Air consumption Nit/min [SCFM]

The curves and performance values refer to pumps with submerged suction and a free delivery outlet with water at 20°C. These data may vary according to the construction materials and hydraulic conditions.

## DIMENSIONS

	A	B	C	Weight Kg	Temperature	
<b>PTFE</b>	275 mm	210 mm	334 mm	28,3 kg	-20 °C	+95 °C
<b>PTFE+CF</b>	275 mm	210 mm	334 mm	28,3 kg	-20 °C	+95 °C
<b>PE</b>	275 mm	210 mm	334 mm	28,3 kg	-20 °C	+95 °C
<b>PE+CF</b>	275 mm	210 mm	334 mm	13,83 kg	-4 °C	+65 °C
<b>PP</b>	275 mm	210 mm	334 mm	13,83 kg	-4 °C	+65 °C

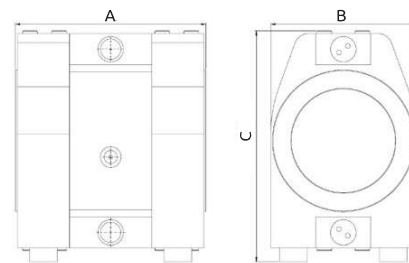

## COMPOSITION

MODEL	CASING	DIAPHRAGM	BALLS	SEATS	GASKET	CONNECTIONS	ATEX	PORTS
AML025	T = PTFE	DT = EPDM+PTFE	T = PTFE	T = PTFE	T = PTFE	1 = BSP	- = zone 2	EF = STANDARD
	TC = PTFE+CF	D = EPDM	S = SS	Z = PE	F = FEP+FKM	2 = FLANGED	X = zone 2	
	Z = PE		D = EPDM	PP = PURE PP	D = EPDM	5 = NPT		
	ZC = PE+CF							
	PP = PURE PP							

Central block in POLYETHYLENE, available, on request, in PTFE





## TECHNICAL DATA

- Fluid connections **1" 1/2 BSP**
- Air connection **1/2" BSP**
- Max. Flow rate **290 lt/min**
- Max air pressure **8 bar**
- Max delivery head **80 mt**
- Max Suction Lift Dry **5 mt**
- Max Suction Lift Wet **9,8 mt**
- Max Solid passing **4,5 mm**
- Noise level **75 dB**
- Max Viscosity **35.000 cps**
- Displacement per Stroke **650 CC ~**

Ⓢ II 3/3 G Ex h IIC T4 Gb  
 Ⓢ II 3 D Ex H IIIB T135°C Db X

Displacement per stroke may vary based on suction condition, discharge head, air pressure and fluid type.

## PERFORMANCE

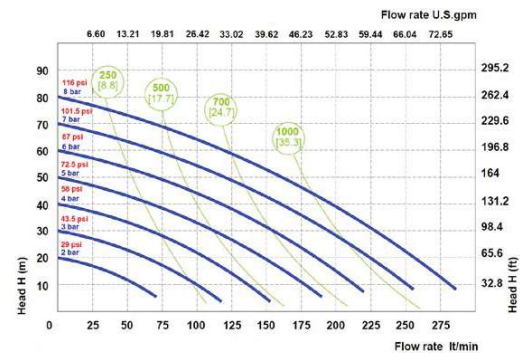

○ Air supply pressure  
 ○ Air consumption Nit/min [SCFM]

The curves and performance values refer to pumps with submerged suction and a free delivery outlet with water at 20°C. These data may vary according to the construction materials and hydraulic conditions.

## DIMENSIONS

	A	B	C	Weight Kg	Temperature	
PTFE	359 mm	291 mm	465 mm	80 kg	- 20 °C	+ 120 °C

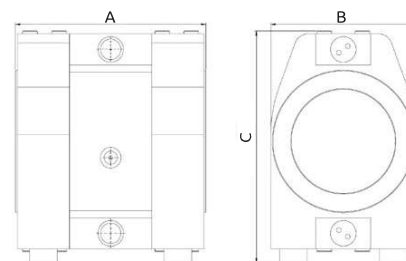

## COMPOSITION

MODEL	CASING	DIAPHRAGM	BALLS	SEATS	GASKET	CONNECTIONS	ATEX	PORTS
AML0040	T = PTFE	DT = EPDM+PTFE	T = PTFE	T = PTFE	FP = FEP	1 = BSP 2 = FLANGED	= zone 2	EF = STANDARD

Central block in POLYETHYLENE, available, on request, in PTFE