

# POOL PUMPS

## **Supastream**

Supastream pumps are general purpose units designed for use in swimming pools and low pressure water recirculation applications.

## **Supatuf**

The Supatuf pump is ideal for large domestic swimming pools with ancillary systems such as heating, in-floor cleaning, fountains, vacuum cleaning and swim jets.



## Efficient Impeller and Diffuser Design

The pump's impeller and diffuser design maximizes the hydraulic output of the pump while minimizing turbulence. The pump's efficient hydraulic performance shortens run times and reduces energy consumption leading to lower operating costs.

## Engineered Durability

The pump body is manufactured utilising state of the art engineering plastic moulding with a single piece strainer pot and volute for extra strength.

A high grade 316 stainless steel mechanical seal is incorporated for extra protection against corrosion. e.g. from chlorinated water, ozone, iodine, Baquacil, bromine and salt water.

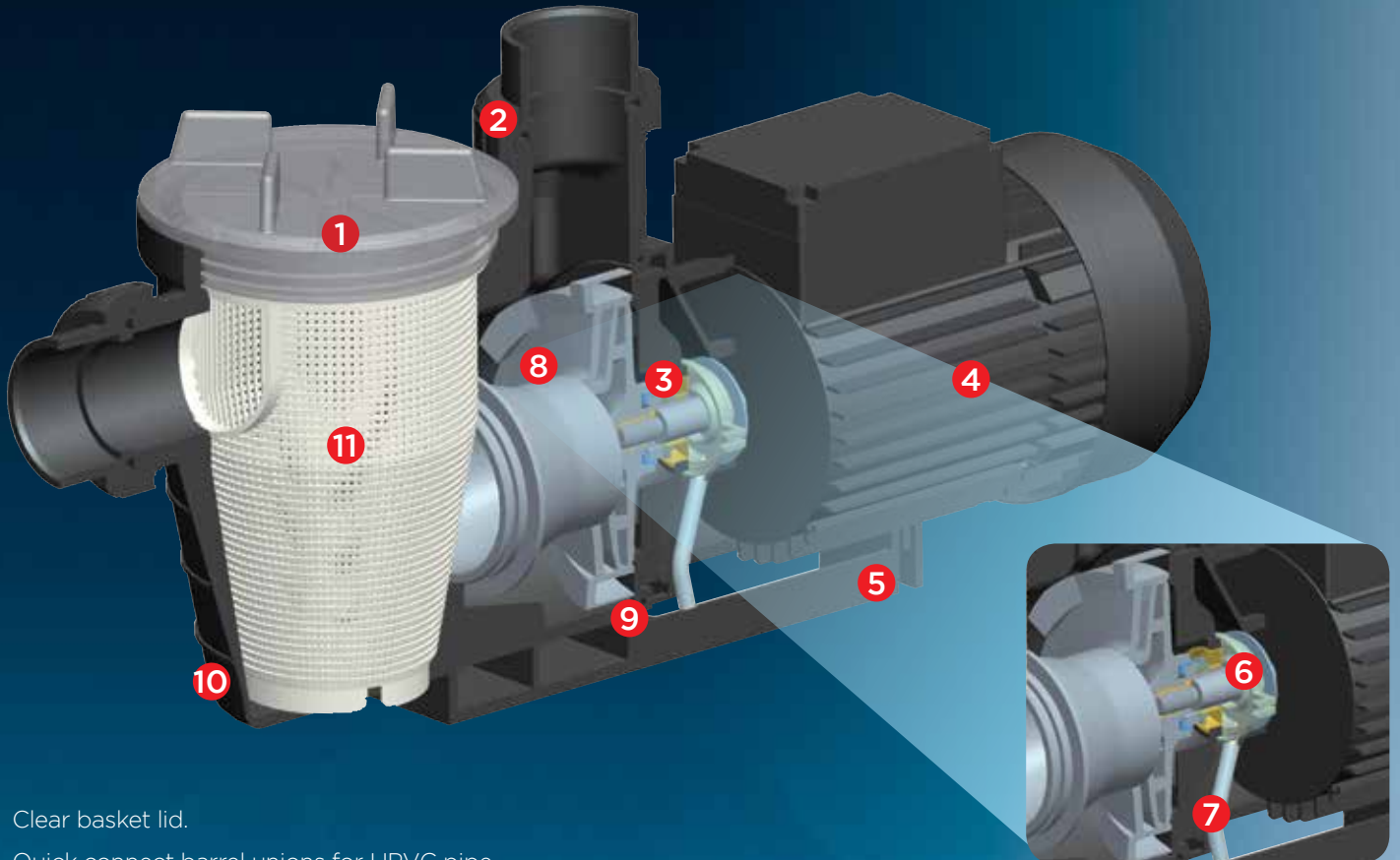

1. Clear basket lid.
2. Quick connect barrel unions for UPVC pipe.
3. High grade carbon/graphite mechanical seal with 316 stainless steel spring assembly.
4. High performance motor:
  - IP44 rating
  - Motor shaft 303 grade stainless steel.
  - Fan cooled.
  - Thermal overload protection
5. Stable support base.
6. Secondary Seal - For extra protection of the pump motor.
7. Secondary seal drain pipe.
8. Hydraulically efficient impeller and diffuser design.
9. Drain plugs.
10. Strong single piece glass filled thermoplastic pump body.
11. Strainer basket - capture debris and protects the pumps impeller.

## Secondary Seal

Situated between the pump wet end & the pump motor, a mechanical seal forms a seal around the motor shaft to prevent water from running out along the shaft of a motor. The mechanical seal is the wearing part of any pool pump.

A mechanical seal may leak water if the pump is ever run dry or simply be worn out. If a leaky mechanical seal is not replaced promptly, water will travel up the shaft of the motor and ruin the motor in a very short period of time.

Waterco's Secondary Seal protects the pump motor's end shield from any water contact, by capturing any leaks through a worn out mechanical seal and draining it out of the pump.

## Supastream

Supastream pumps are general purpose units designed for use in swimming pools and low pressure water re-circulation applications.



Pump	Inlet / outlet	Strainer basket size
Supastream 50	40mm	1.5
Supastream 75,100 & 150	40/50mm	1.5

### Flow Curves

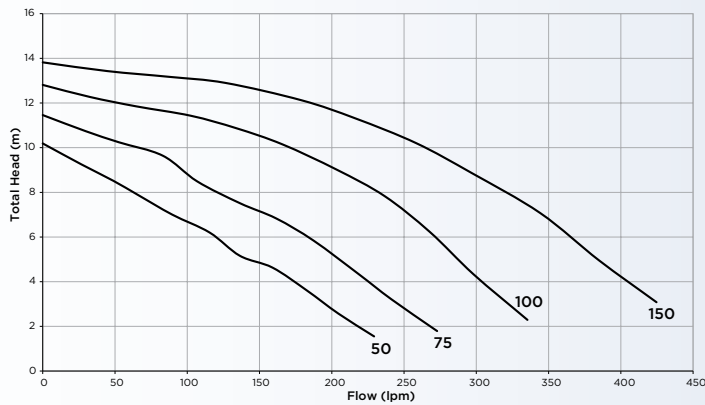

### Noise Levels

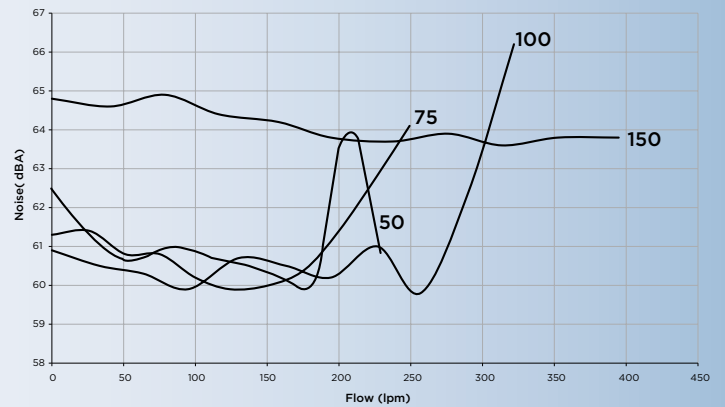

Model	Flow Rate (lpm)		Nom. HP	kW	Amps	Total Length (mm)
	6m	8m				
Supastream 50	60	120	0.50	0.563	2.55	575
Model	Flow Rate (lpm)		Nom. HP	kW	Amps	Total Length (mm)
	8m	10m				
Supastream 75	119	63	0.75	0.626	2.82	575
Supastream 100	234	169	1.00	0.793	3.50	575
Supastream 150	320	263	1.50	1.056	4.76	596

Phase	Volts	Cycle	RPM
1	220-240	50	2810

### Supastream 50

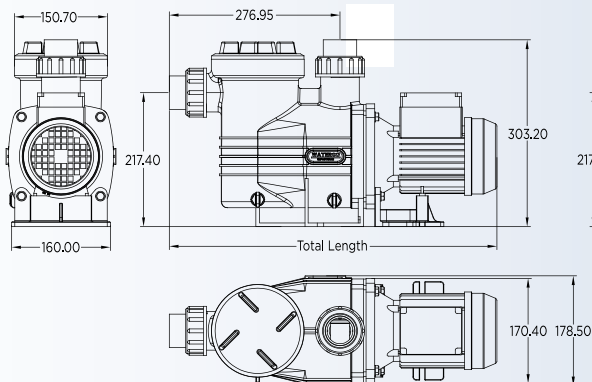

### Supastream 75, 100 & 150

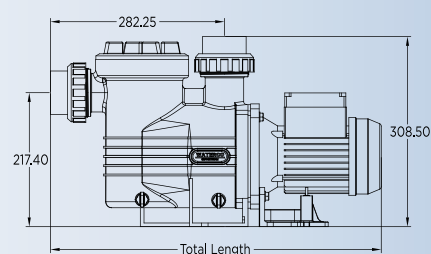

## Supatuf

The Supatuf pump is ideal for large domestic swimming pools with ancillary systems such as heating, in-floor cleaning, fountains, vacuum cleaning and swim jets.



Pump	Inlet / outlet	Strainer basket size
Supatuf	50mm	2.1

### Flow Curves

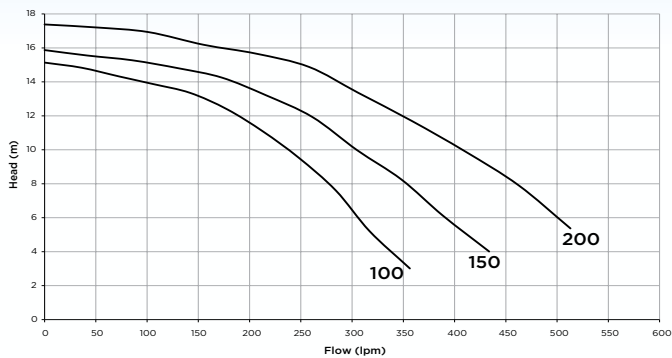

### Noise Levels

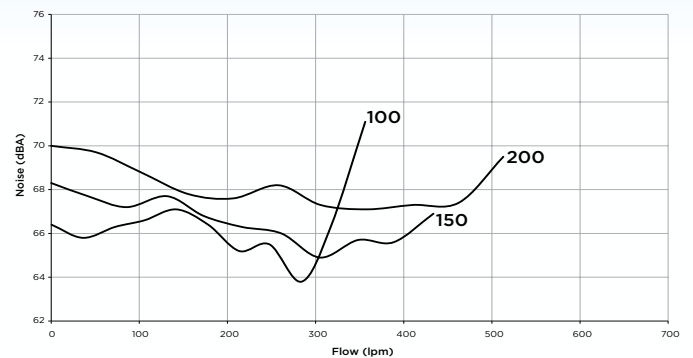

Model	Flow Rate (lpm)		Nom. HP	kW	Amps	Total Length (mm)	Motor Frame (mm)
	8m	10m					
Supatuf 100	275	240	1.00	0.84	3.70	587	71
Supatuf 150	355	305	1.50	1.15	5.30	608	80
Supatuf 200	465	410	2.00	1.50	7.20	629	80

Phase	Volts	Cycle	RPM
1	220-240	50	2860

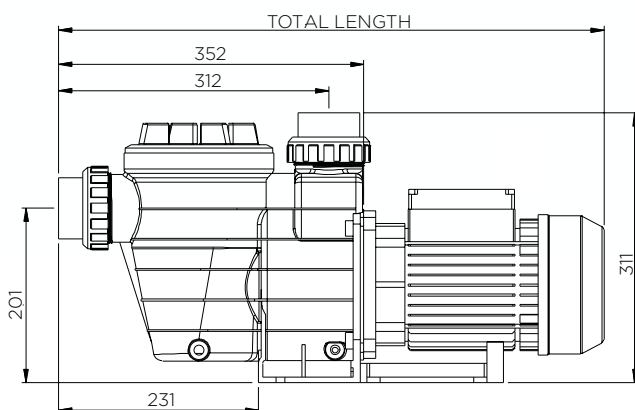

### Warranty

Pumps	3 years (conditional)*
Wet End	3 years
Motor, mechanical seal, hair & lint pot lid, o'ring, basket, impeller & diffuser	2 years
Commercial applications	1 year
Labour	1 year

Note: Waterco Pumps are tested to Australian Standards AS/ NZS3136.

#### OFFICES - AUSTRALIA

NSW - Sydney (Head Office)  
Tel: +61 2 9898 8600  
QLD - Brisbane  
Tel: +61 7 3299 9900  
VIC/TAS - Melbourne  
Tel: +61 3 9764 1211  
WA - Perth  
Tel: +61 8 9273 1900  
SA/NT - Adelaide  
Tel: +61 8 8244 6000  
ACT Distribution  
Tel: +61 2 6280 6476

#### OFFICES - OVERSEAS

Waterco (Europe) Limited  
Sittingbourne, Kent, UK  
Tel: +44 (0) 1795 521 733  
Waterco (USA) Inc  
Augusta, Georgia, USA  
Tel: +1 706 793 7291  
Waterco Canada  
Longueuil, Quebec, Canada  
Tel: +1 450 748 1421  
Waterco (NZ) Limited  
Auckland, New Zealand  
Tel: +64 9 525 7570

Waterco (C) Limited  
Guangzhou, China  
Tel: +86 20 3222 2180  
Waterco (Far East) Sdn Bhd  
Selangor, Malaysia  
Tel: +60 3 6145 6000  
PT Waterco Indonesia  
Jakarta, Indonesia  
Tel: +62 21 4585 1481  
Waterco Singapore Intl Pte Ltd  
Nehsons Building, Singapore  
Tel: +65 6344 2378

### DISTRIBUTED BY:

**WATERCO**  
water, the liquid of life

