

## Content & Feature

1 Product

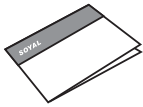

2 User Guide



3 Terminal Cables

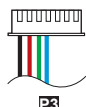

4 Optional



AR-WG-KEYBOARD

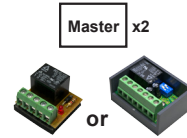

AR-821-RB AR-721-RB

5 Feature

- Standalone and Networking model for selection
- 1 Bi-color LED & 1 Buzzer
- Built-in Watch Dog to prevent system from hanging
- The Master Card function for adding/ deleting cards
- Can set parameters by external keyboard

## Connector Table

### Stand-Alone [NO lift control]

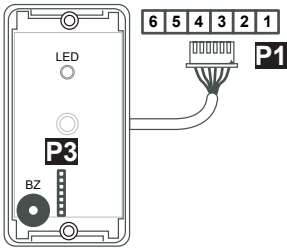

### Standalone: P1 6 PIN (NO RS-485)

Application	Wire	Color	Description
Power	1	Black	DC 0V (GND)
R.T.E	2	Brown	Negative Trigger Input
Power	3	Red	DC 12V
Door Contact	4	Orange	Negative Trigger Input
Alarm Relay	5	Yellow	Open collector output
Lock Relay	6	Green	Open collector output/ Security Trigger Signal

### P3 WG-KEYBOARD Socket

Application	Wire	Color	Description
---	1	---	---
---	2	---	---
---	3	---	---
WG	4	Blue	WG DATA 1
WG	5	Green	WG DATA 0
Power	6	Red	DC 12V
Power	7	Black	DC 0V (GND)

### Networking

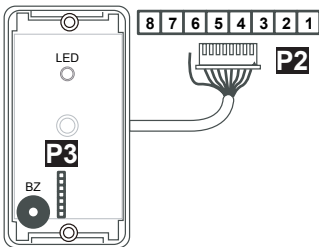

### Networking: P2 8 PIN + GND (RS-485)

Application	Wire	Color	Description
Power	1	Black	DC 0V (GND)
Power	2	Red	DC 12V
Alarm Relay	3	Gray	Open collector output
R.T.E	4	Purple	Negative Trigger Input
Door Contact	5	Orange	Negative Trigger Input
Lock Relay	6	White	Open collector output/ Security Trigger Signal
RS-485	7	Blue	RS-485 A+
RS-485	8	Green	RS-485 B-

### P4 TTL Cable (Optional)

Application	Wire	Color	Description
TTL	1	Yellow	TX
TTL	2	White	TE
TTL	3	Orange	RX
---	4	---	---
---	5	---	---
Power	6	Red	DC 12V
Power	7	Black	DC 0V (GND)

- When update firmware or set function for standalone model, please order P4.
- Please unplug P3 cable before using P4 cable.

## Diagram

### Connect to Electric Strike

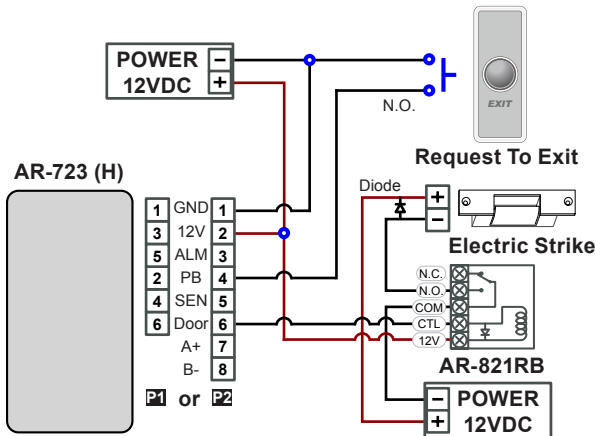

※ P1 are not in order, please refer to [Connector Table]

### Strengthen security with AR-721RB

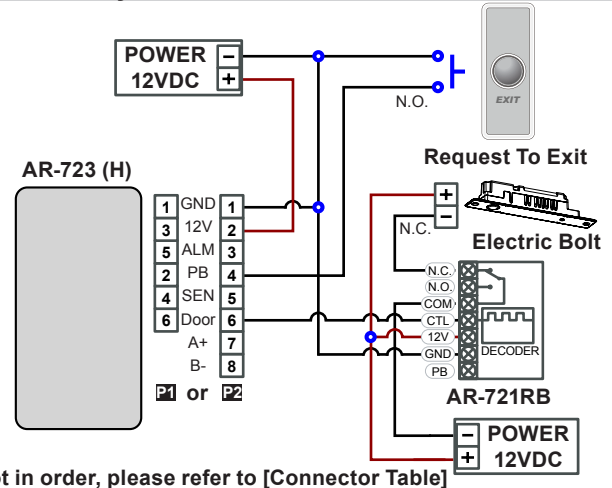

※ P1 are not in order, please refer to [Connector Table]

### Connect to Door Contact and Alarm

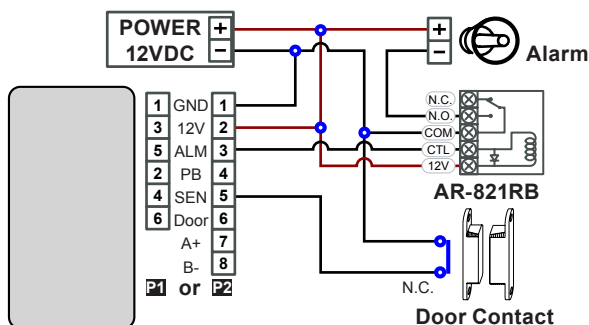

※ P1 are not in order, please refer to [Connector Table]

### Connect to Reader or Keyboard

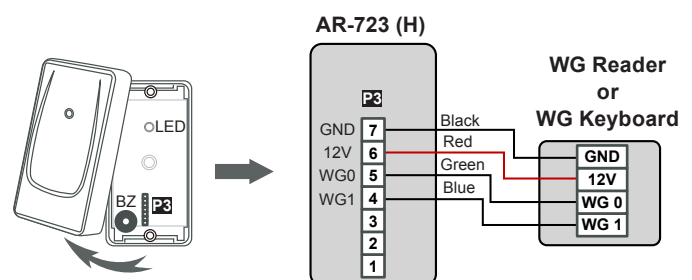

- Please unload the cover before plug in P3 cable.
- If you need to use P4 cable, unplug P3 cable and then plug in P4 cable.

## About Master Card

### MASTER CARD Setting for Stand-Alone

- Plug in **P4** cable instead of **P3** cable, the wire connection is as below figure. After connection, then have power transmission to controller.

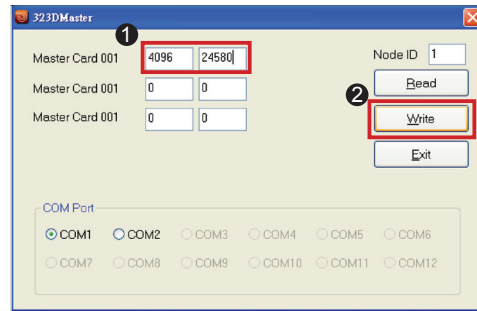
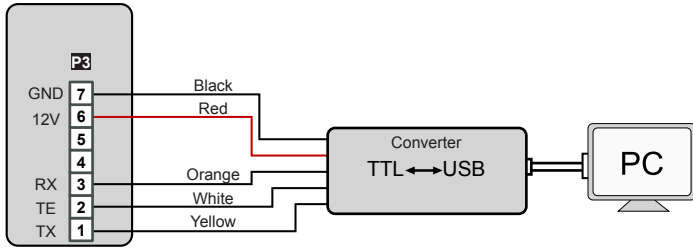

- Use the MASTER CARD software



- Input the MASTER CARD number, and press [Write].
- Cut off and then transmit the power, the master card number will be activated.
- Present the card, and the reader will flash green light 3 times and sound 3 beeps. Then the card becomes MASTER CARD and accesses programming mode. If MASTER CARD is presented again, it will exit programming mode.

### Adding Tag

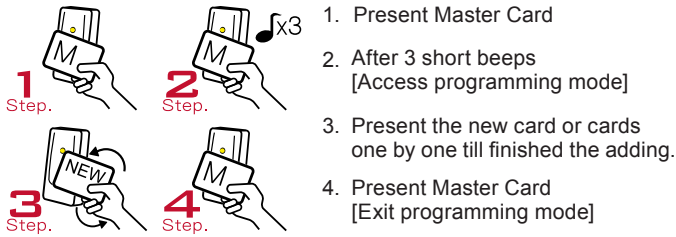

### Deleting All Tags

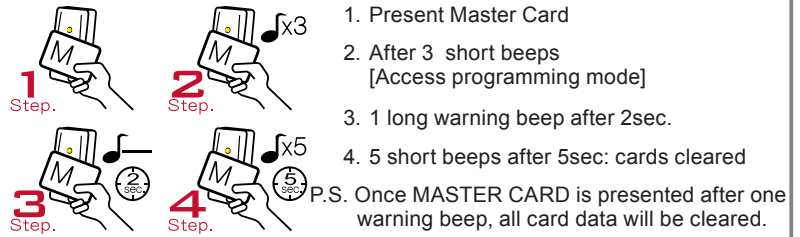

## Operation process

### A. Enter/ Exit Program Mode

- **Enter the program mode**  
Input \*123456 # or \*PPPPPP #  
[e.g.] The Default Value= 123456, if already changed the Master Code= 876112, input \*876112 # → program mode accessed
- **Exit the program mode**  
Input \* #
- **Master Code modification**  
Access programming mode → 09 \*PPPPPPRRRRR # [Input the 6-digit new master code twice.]  
[e.g.] Set the Master code to be 876112, input \*123456 # → 09 \*876112876112 #

### B. Set up the password [Only for connect to external K-series reader]

- **M4/M8: Individual pass code**  
**Card or PIN:** Access programming mode → 12 \*UUUUU \*PPPP # [e.g. User address: 00001 and pass code: 1234, input 12 \*00001 \*1234 #]  
**Card and PIN:** Access programming mode → 13 \*UUUUU \*PPPP # [e.g. User address: 00001 and pass code: 1234, input 13 \*00001 \*1234 #]
- **M6: Public pass word**  
**Card or PIN:** Access programming mode → 15 \*PPPP # [Input 4-digit pass code, default value: 4321]  
**Card and PIN:** Access programming mode → 17 \*PPPP # [Input 4-digit pass code, default value: 1234; PPPP=0000: change into Card Only]

### C. Lift control

Connect with **AR-401RO16B** to control floors which the user will be able to access.

- **Enable**  
Access programming mode → 24 \*002 # [002= enable lift control]
- **Single floor**  
Access programming mode → 27 \*UUUUU \*FF #  
UUUU=User Address FF=Floor number (01~32 floor)  
[e.g.] User address NO. 45, allow to access the 24th floor: 27 \*00045 \*24 #
- **Multi floors**  
Access programming mode → 21 \*UUUUU \*S \*FFFFFFF #  
[UUUUU=User address S: 4 sets of lift control (Input: 0~3) FFFFFFFF: 8 floors setting (F=0=Disable, F=1=Enable)]  
[e.g.] User address NO. 168, only to the 6th and the 20th floor:  
Access programming mode → 21 \*00168 \*0 \*00100000 # → 21 \*00168 \*2 \*00001000 #

Set	Floor/ Stop							
	F	F	F	F	F	F	F	F
0	8	7	6	5	4	3	2	1
1	16	15	14	13	12	11	10	9
2	24	23	22	21	20	19	18	17
3	32	31	30	29	28	27	26	25

## D. Setting Up the Arming [Only for connect to external K-series reader]

- **Alarm conditions:**
  1. Arming is enabled
  2. Alarm system connected
- **Application:**
  1. **Door open too long:** Door is open longer than door relay time plus door close time.
  2. **Force open** (Opened without a valid user card): Access by force or illegal procedure.
  3. **Door position abnormal:** Arming is enabled and the power is suddenly off then on.
- **Enable/Disable Arming status (for M4/M8; Factory default armingcode is: 1234) :**

<b>Standby Mode</b>	
After door open	Do not open the door
The normal procedure to open door → Input 4 digit arming code → #	* → Input 4 digit arming code → Present valid card
<b>Enter Program Mode</b>	
<b>Enable:</b> Access programming mode → * * #	<b>Disable:</b> Access programming mode → * #

※ [The normal procedure to open door] can refer to [Access Mode].

## Function Default Value

20 * DDD #				※Default Value
Function	Selection		Value	Application
Attendance	※0: Yes	1: No	001	Networking
Auto Re-lock	※0: Disable	1: Enable	002	Networking/Stand-Alone
Auto Open	※0: Disable	1: Enable	004	Networking/Stand-Alone
Door open button input	0: Disable	※1: Enable	016	Networking/Stand-Alone
Master Controller of Network	※0: Slave	1: Mater	032	Networking

24 * DDD #				※Default Value
Function	Selection		Value	Application
Auto-open door without cards at auto open zone	※0: Disable	1: Enable	001	Networking/Stand-Alone
Alarm Output/ Lift Control	※0: Alarm Output	1: Lift Control	002	Networking/Stand-Alone
Stop Alarm by door close or by push button	0: None	※ 1: Yes	064	Networking/Stand-Alone

28 * DDD #				※Default Value
Function	Selection		Value	Application
Dual Door Control	※0: Disable	1: Enable	064	Networking/Stand-Alone
Force Open Alarm Output	※0: Disable	1: Enable	128	Networking/Stand-Alone

Selection= 0(none value)/ 1(1 x each value)

[e.g.] DDD value of Enable "Auto Open" + "Exit by Push Button" + "Anti-pass-back"

= (0x1)+(0x2)+(1x4)+(1x16)+(0x32)+(0x64)+(1x128)=148 ; As a result of that, the command will be 20 \* 148 #

## Mode4 / Mode6 / Mode8

Mode	Networking/Stand-Alone	User Capacity	Access Mode	Auto-show Duty time	Event log Capacity	120 Holidays	Anti force	Time Zone	Lift Control	Anti-pass-back
M4	Networking/Stand-Alone	1,024	1.Card only 2.Card and PIN (4-digit PIN)+ # 3.Card or User address (5-digit) + Individual PIN (4-digit individual PIN) + #	Yes	1,200	Yes	Yes	No	32	Yes
M6	Stand-Alone	65,535	1.Card only 2.Card and PIN (4-digit public PIN= Arming PWD)+ # 3.Card or PIN (4-digit public PIN= Duress code)	No	No	No	No	No	No	No
M8	Networking/Stand-Alone	1,024	1.Card only 2.Card and PIN (4-digit individual PIN)+ # 3.Card or PIN (4-digit individual PIN)	Yes	1,200	Yes	Yes	No	32	Yes

※ **Mode 6**, the number of users up to 65535, since it reads **CARD CODE**(5 digits) only, unlike that Mode4/Mode8 read **SITE CODE** and **CARD CODE**(10 digits).  
If **Access Mode setting to use the PIN**, it need to external the K-series Readers.

## Factory Reset by its commands

- **When the device is stand-alone (not networking)**

Access programming mode → 20 \* 016 # → 24 \* 064 # → 26 \* 00000 \* 01023 \* 1 # → 28 \* 000 # → 29 \* 29 \* #

※Note: After the Master Code is changed, factory reset doesn't restore the Master Code back to 123456.

## Command List

Function	Command	Description	Mode
Entering programming mode	* PPPPPP #	PPPPPP=Master Code, default value=123456	M4/M6/M8
Exiting programming mode	* #		M4/M6/M8
Exiting programming mode and enabling arming status	* * #		M4/M8
Node ID setting (Connecting to 716E)	00 * NNN #	NNN=Node ID, range: 001~254	M4/M8
Node ID setting (Connecting to PC directly without via 716E)	00 * NNN * VVV * nnn #	NNN=Node ID of Access Controller, VVV=Virtual 716E Node ID, nnn=Door number; range:001~254	M4/M8
Mifare tag / card format (Optional)	01 * N #	N: 0=ISO14443A; 1=ISO14443B; 2=ISO15693; 3=I Code1; 4=I Code2 PS.1. Please select the compliance,first. 2. Make sure reader and card using the same compliance.	M4/M8
Door relay time setting	02 * TTT #	TTT=Door relay time 000= Output constantly 001~600=1~600 sec. 601~609=0.1~0.9 sec.	M4/M6/M8
Alarm relay time setting	03 * TTT #	TTT=Alarm relay time 001~600=1~600 sec.	M4/M6/M8
Control mode setting	04 * N #	N=Mode 4=Mode4; 6=Mode6; 8=Mode8	M4/M6/M8
Arming delay time setting	05 * TTT #	TTT=Alarm relay time 001~600=1~600 sec.	M4/M6/M8
Alarm delay time setting	06 * TTT #	TTT=Alarm delay time 001~600=1~600 sec.	M4/M6/M8
Master card setting	07 * SSSSS * EEEEE #	SSSSS-EEEE=00000-01023 (00000-03000 for AR-725H); SSSSS=Starting user address; EEEEE=Ending user address	M4/M8
Auto-open time zone setting	08 * N * HHMMhhmm * 6543217H #	N= 0(1st time zone) / 1(2nd time zone) HHMM= Starting time; hhmm= ending time (i.e.: 08301200=08:30 to 12:00) 6543217H= 7 days of week (Sat/Fri/Thu/Wed/Tue/Mon/Sun)+ Holiday (F= 0: disable; 1: enable); Holidays establish by the software.	M4/M6/M8
Master code setting	09 * PPPPPRRRRRR #	PPPPPP=New master code RRRRRR=Repeat the new master code	M4/M6/M8
Setting	Suspend tag(M6)	10 * SSSSS * EEEEE #	* =Suspend 9 =Delete;
	Delete tag(M4)	10 * SSSSS 9 EEEEE #	SSSSS=Starting user address, EEEEE=Ending user address
Set a sequence of cards as "read and access"	11 * SSSSS * EEEEE #	SSSSS=Starting card number; EEEEE=Ending card number	M4/M8
Active the suspended cards	11 * SSSSS * EEEEE #	SSSSS=Starting user address; EEEEE=Ending user address	M4/M8
Set the cards as Card mode OR PIN mode by user address	12 * UUUUU * PPPP #	Access mode: <b>Card or PIN</b> ; UUUUU=user address; PPPP=4-digit pass code 0001~9999	M4/M8
Set the cards as Card AND PIN mode by user address	13 * UUUUU * PPPP #	Access mode: <b>Card and PIN</b> ; UUUUU=user address; PPPP=4-digit pass code 0001~9999	M4/M6/M8
M4: Duress code setting M6: Public PIN setting (Card or PIN)	15 * PPPP #	PPPP=4-digit pass code (default value=4321) P.S. Duress code will be unavailable and become a public PIN at access mode "Card or PIN" of M6	M4/M8
Card number modification	16 * UUUUU * SSSSSCCCC #	UUUUU= User address; SSSSS=5-digit site code; CCCCC=5-digit card code	M4/M6/M8
M4: Arming pass code setting M6: Public PIN setting (Card and PIN)	17 * PPPP #	PPPP=4-digit pass code ( default value=1234; disable Arming PWD=0000) P.S. Arming PWD code will be unavailable and become a public PIN at access mode "Card PIN" and of M6	M4/M6/M8
Door open waiting time	18 * TTT #	TTT=Door open waiting time: 001~600=1~600 sec.; default value: 15 sec.	M4/M8
Set the card by induction (M4)	19 * UUUUU * QQQQ #	UUUUU=User address; QQQQ=Card quantity(0001=Continuously inducting)	M4/M6/M8
Reader additional setting	20 * DDD #	Please refer to function default value for details.	M4/M6/M8
Lift control setting: multi-doors	21 * UUUUU * S * FFFFFFFF #	UUUUU=User address, S=4 sets of lift control(0~3); FFFFFFFF=8 assigned floor (F=0: Disable, 1: Enable)	M4/M8
Add/Delete tag by induction (M6 only)	22 * N #	N=0(Delete tag); N=1(Add tag)	M6
AR-401ROsite number dip switch	23 * NNN * TTT #	NNN=site number, TTT= relay time: 000~600=1~600 sec.	M4/M8
Controller parameter setting	24 * DDD #	Please refer to function default value for details.	M4/M6/M8
Controller time clock setting	25 * YYMMDDHHmmss #	YYMMDDHHmmss: Year/ Month/ Day/ Hour/ Min./ Sec.	M4/M6/M8
Anti-pass-back (Enable user)	26 * SSSSS * EEEEE * N #	SSSSS=Starting user address; EEEEE=Ending user address; N=0/Enable; N=1/Disable; N=2/Initial	M4/M8
Single floor setting	27 * UUUUU * FF #	UUUUU=User Address; FF=Floor (01~32 floor)	M4/M8
Dual door control/ Active or inactive arming for force open	28 * DDD #	Please refer to function default value for details.	M4/M6/M8
Delete all tags	29 * 29 * #		M4/M6/M8
Enable the security trigger signal ( with AR-721RB)	34 * 064 # (Enable)	To Change the "Door Lock" become the security trigger signal, when controller is connected with AR-721RB.	M4/M6/M8
	34 * 000 # (Disable)		