

XP-GT/GTR

**SINGLE DOOR ACCESS
CONTROL SYSTEM**

PROGRAMMING MANUAL

Version 3.00

MicroEngine XP-GT/GTR Controller Programming Manual

Revision History

Version	Date	Remarks
1.00	1/1/2007	First Release of Manual
2.00	8/3/2008	Updated arrangements and drawings
2.10	17/7/2008	Updated drawings and included the XP-GTR series to the manual. Also added a page to indicate scope of manual.
3.00	20/7/2009	Updated System Menu, added Alarm Menu and wiring diagram for XP-GTR to MIO44. Also added the connection for XP-GT/GTR using sounder and fire release feature.

Scope:

This manual covers the following products

1. **XP-GT1200**
2. **XP-GT3200**
3. **XP-GT1200L**
4. **XP-GT3200L**
5. **XP-GTR1200**
6. **XP-GTR3000**
7. **XP-GTR1200L**
8. **XP-GTR3000L**

Table of Contents

1.XP-GT/GTR Single Door Access Control System.....	6
1.1Powering Up.....	6
1.2Idle Mode.....	7
1.3Token Operation	7
1.4Token+PIN Operation	8
1.5Token+Fingerprint Operation	8
1.6Token+PIN+Fingerprint Operation	8
1.7Symbols.....	9
2.Programming Environment.....	10
2.1Programming Menu Layout.....	10
2.2Keypad Button Functions Keypad Button Functions.....	10
2.3Entering Programming Mode.....	10
3.System Menu.....	12
3.1Set Date and Time.....	12
3.2Door Parameter.....	13
3.3Time Set	18
3.4Time Zone	20
3.5Holiday Setting.....	23
3.6General Parameter.....	24
3.7Network Parameters.....	26
3.8Sounder Setting.....	28
3.9O/P Trigger Events.....	29
4.Database Menu.....	30
4.1Quick Add User.....	30
4.2Add User.....	31
4.3Delete User.....	33
4.4Edit User Settings.....	34
4.5Clear Anti PassBack.....	35
4.6Clear Card LockOut.....	36
4.7Clear All User.....	36

5.Fingerprint Menu.....	38
5.1Add Fingerprint.....	38
5.2Delete Fingerprint.....	40
5.3Clear Fingerprint.....	40
5.4Template Enrolled.....	41
5.5Set Security Level.....	41
6.Maintenance Menu.....	43
6.1Master PIN.....	43
6.2Clear Transaction.....	44
6.3Test Watchdog.....	44
6.4Version.....	45
6.5Information.....	45
7.Alarm Menu.....	46
7.1Input Setting.....	46
7.2Output Setting.....	48
7.3Panel Status.....	50
8.Exit Programming Menu.....	51
Appendix 1 – General Wiring for XP-GT using MAS-RBT.....	52
Appendix 2 – General Wiring for XP-GTR using MAS-RBU.....	53
Appendix 3 – General Wiring for two XP-GT using MAS-RBT.....	54
Appendix 4 - Connection for XP-GT using sounder feature.....	55
Appendix 5 - Connection for XP-GTR using sounder feature.....	56
Appendix 6 - Connection for XP-GT and XP-GTR using fire release feature.....	57
Appendix 7 - Connection for XP-GTR to MIO44.....	58

1. XP-GT/GTR Single Door Access Control System

1.1 Powering Up

Before powering up the device for the first time, please check that all the connection of the hardware are connected properly according to the wiring diagram.

When powering up the reader for the first time, be sure to perform a ColdStart operation. ColdStart is a process that will erase all the memory in the device and reset all the settings to default. User only needs to do a ColdStart **once** for new installation unless advised to do so.

To perform a ColdStart, please follow the steps below:

1. Turn ON the power supply. The screen below will be shown



2. While the console is starting up, press the # button. You will be prompted with an option to ColdStart.
3. Press '√' if you wish to ColdStart the system, or 'X' if you want to cancel.
4. Press '√' again if you would like to confirm the ColdStart. Wait until the ColdStart process is finished and the console will enter Idle Mode.

1.2 Idle Mode

In Idle Mode, the LCD display is shown as below.

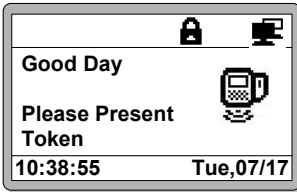

The controller will give audio and visual indication to users in different circumstances. Table below shows normal response in Idle Mode:

Condition	LCD Display	Buzzer
Idle Mode	1. Request for a token to be presented. 2. Indicate time, date and day in 'HH:MM:SS' and 'DAY,MM/DD' format. 3. Backlight is dimmed.	OFF

1.3 Token Operation

Token only the default operation mode of device. If the token type is set as a card, then the user has to present a card to identify himself. If the token type is a pin, then the user has to present a card to identify himself. To read the card, place the card near the keypad area. The time interval between successive reading of the same card number is 2 seconds. The card is installed using the Database Menu, by adding a New User or Quick Add User. Various verification mode can be selected, as explained later in the manual.

Table below shows response in Card Operation Mode:

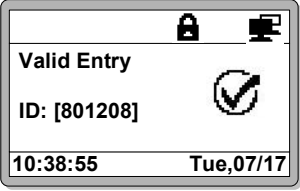
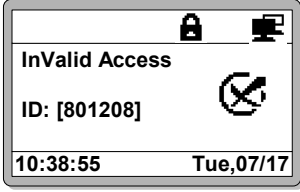
Condition	LCD Display	Buzzer
Valid Token	 <p>The LCD display shows a lock icon and a computer icon at the top right. The text reads: "Valid Entry", "ID: [801208]", and "10:38:55 Tue,07/17". A checkmark icon is displayed on the right side.</p>	1 beep
Invalid Token	 <p>The LCD display shows a lock icon and a computer icon at the top right. The text reads: "InValid Access", "ID: [801208]", and "10:38:55 Tue,07/17". A crossed-out circle icon is displayed on the right side.</p>	3 beeps

1.4 Token+PIN Operation

Every user will have its own four-digit pin number. In Card+PIN Operation Mode, users need to enter the pin number after flashing. This provides higher security.

Note: All newly installed cards by using the Card DB menu will have a default pin number of **1234**. To change the pin number please refer to Edit User Setting.

1.5 Token+Fingerprint Operation

Users can opt to use the Card+Fingerprint mode for higher security. Each user can enrol up to 5 fingerprints for this purpose. For enrolment of fingerprint, please refer Fingerprint Menus.







1.6 Token+PIN+Fingerprint Operation

For maximum security, the console can be set to accept Card+Pin+Fingerprint before allowing access.

Note: All items in the fingerprint functions are only applicable to XP-GT series of controllers

1.7 Symbols

Listed below are the common symbols that are used in the operation.

Symbol	Name	Indication
	AntiPassBack	AntiPassBack Mode enabled. Once enabled, the user will not be able to use the same card to gain access through the same direction repeatedly without gaining access on the opposite direction.
	CardLockOut	CardLockOut Mode enable. Once enabled, the token will be locked permanently after failure to gain access for three consecutive times. The failure might be caused by wrong pin number, wrong time zone or anti pass back violations.
	Higher Security	In Higher Security Mode, users need to enter the comply to the pre-set verification mode after to gain access. This provides higher security.
	Security On	Security Mode enabled. Users must adhere to the verification mode settings to gain access.
	Security Off	Security Mode Disabled, which will cause the lock to be permanently released.
	Uplink communication	Communication has been established with the remote server to allow the sending and receiving of data when this icon is blinking.
	Downlink Communication	Communication has been established with the relay board when this icon appears

2. Programming Environment

This section covers the programming environment of the MicroEngine XP-GT/GTR series of controllers. These controllers have an LCD display and 4x4 keypad to allow user to perform programming.

2.1 Programming Menu Layout

The diagram below shows the menu layout when the controller is in programming mode.

2.2 Keypad Button Functions Keypad Button Functions

1. To choose a menu or function, just key in the number correspond to menu or function. E.g. In the Main Menu, pressing '1' will enter the System Menu.
2. Use '0-9' to key in card number, pin number or numeric value for certain functions.
3. Use 'X' to cancel a function or go to the previous screen.
4. Use '√' to select a parameter to change/confirm a setting or value.
5. Press '↑' or '↓' to toggle between options/scroll up or down the menu.

2.3 Entering Programming Mode

The controller can be programmed through two methods:

- i. MicroEngine xPortal2005/xPortal2007 software application.
- ii. On-board keypad programming.

This manual will describe how to configure the controller using the built in keypad. To enter Programming Mode you need to follow these procedure:

1. Press '*' (asterisk).
2. Key in the 6 digits MasterPIN (default MasterPIN = **123456**). The MasterPIN can be configured in the Maintenance Menu.

Once you have entered the Programming Mode, you will be able to see options as shown in figure below.

In general, the **System** option will contain all settings which has to do with the operation of the unit. The **Database** option contains all settings related to the management of card holders like adding and deleting cards and changing settings for each individual cards. The **Fingerprint** option contains settings related to fingerprint recognition, including adding new fingerprint. The **Maintenance** option contain settings related to the housekeeping of the unit. This option will also provide information on number of users installed and firmware version. Further details of these configurations will be covered in the coming chapters.

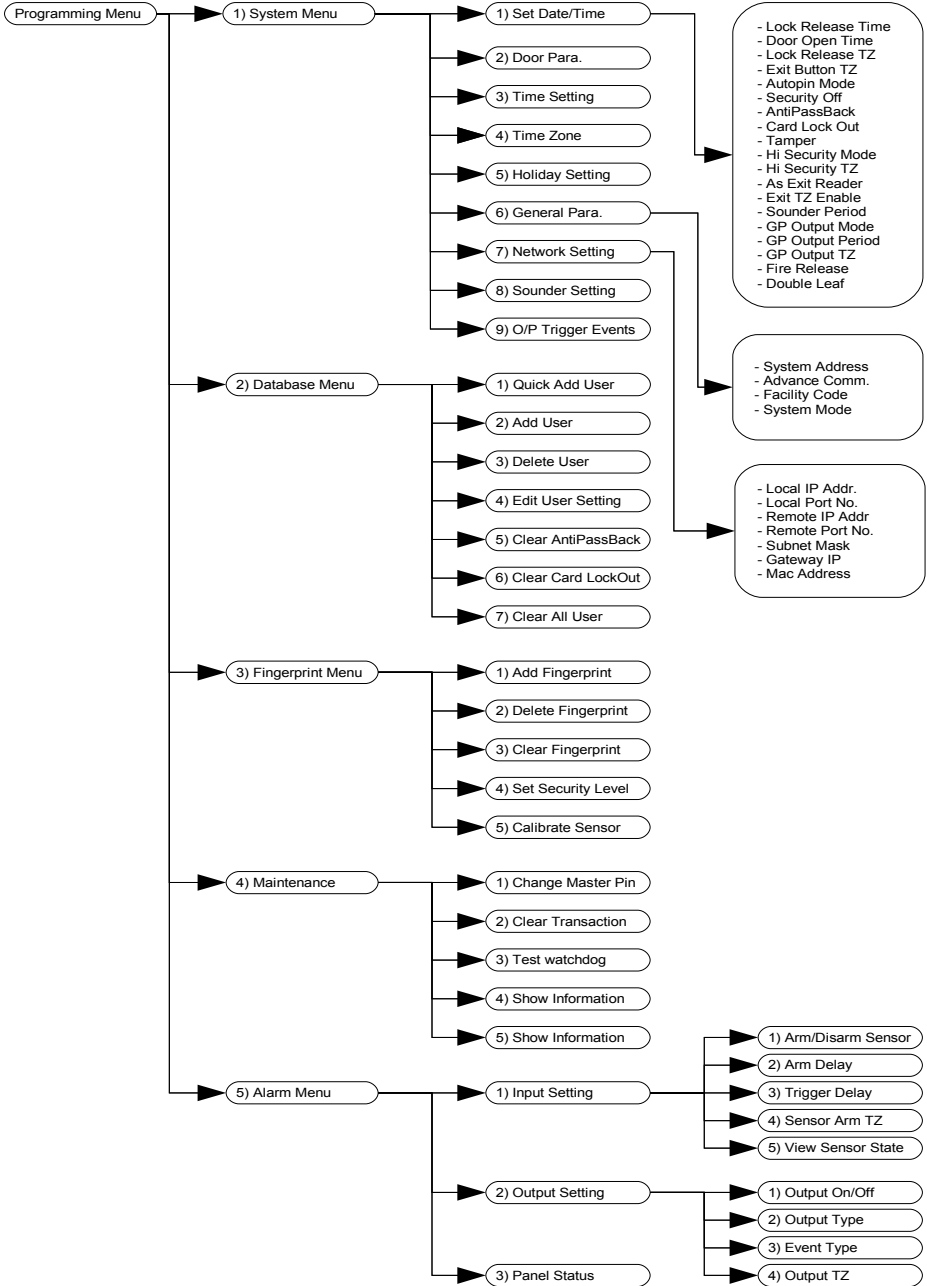

3. System Menu

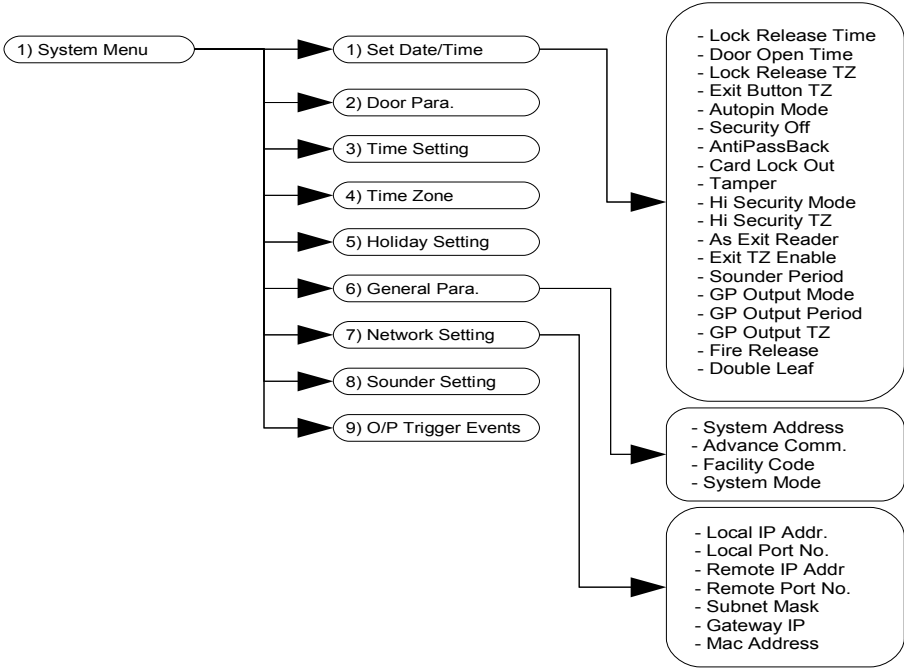

3.1 Set Date and Time

This menu allows user to change the date and time of the device. The system date and time is important because it will affect event transactions logging, time and date dependent functions that uses Time Set and Time Zone and also holiday settings.

To edit the date and time setting, please follow steps below:

1. Enter Programming Mode.
2. Press '1' for System Menu.
3. Press '1' for Set Date/Time. Screen as below will be shown.

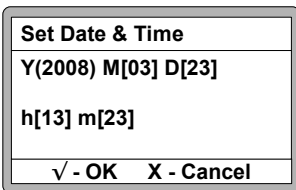

4. The field with the '()' is the value currently editing. Press '√' to accept the pre-set values or press 'X' any time to exit from Set Date/Time menu without saving any changes.
5. Key in four digits value for year and press '√' to confirm and proceed on to next field.
6. Key in two digits value for month and press '√' to confirm and proceed to next field.
7. Key in two digits value for date and press '√' to confirm and proceed to next field.
8. Key in two digits value for hour. The time is in 24-Hour format. Press '√' to confirm and proceed to next field.
9. Key in two digits value for minute and press '√' to confirm and a confirmation screen will be shown as below.

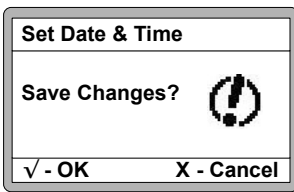

Tips: If the controller has established communication with the software application, the date and time will be automatically synchronize with the PCs date and time.

3.2 Door Parameter

This menu lets user set the operation of the controller.

To edit the door parameter setting, please follow steps below:

1. Enter Programming Mode.
2. Press '1' for System Menu.
3. Press '2' for Door Parameter. The screen below will be displayed.
4. Use the '↑' and '↓' buttons to navigate the menu to the desired parameter.
5. Edit the values for the parameter by pressing '√', followed by the desired value and '√' again to confirm.
6. The changes will not be saved if the configuration is interrupted midway.
7. The menu is shown below, with the list of parameters that can be set.

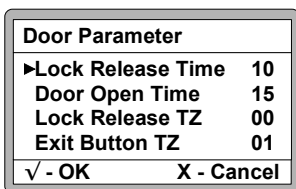

8. Use the ' X ' button to return to the system menu.
9. You will be prompted to confirm your changes before exiting. Press ' √ ' to confirm changes.

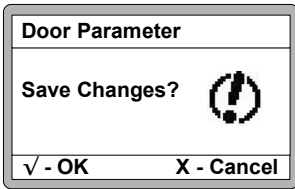

1. List of parameters includes:
 - i) **Lock Release Time**
 Description : Duration for the lock to be released every time a valid access is gained.
 Value : 00 - 99 seconds.
 Default value : 10 seconds.
 - ii) **Door Open Time**
 Description : Duration for the Door to be open before being considered as Door Left Open.
 Value : 00 - 99 seconds.
 Default value : 15 seconds.
 - iii) **Lock Release Time Zone**
 Description : Time Zone setting for Automatic Lock Release. This will determine at which day of the week and what time of the day will the lock be automatically released.
 Value : 00 – 50.
 Default value : 00.
 - iv) **Exit Button Time Zones**
 Description : Time Zone setting for Exit Button. This will determine at which day of the week and what time of the day where the exit push button will be enabled.
 Value : 00 – 50.
 Default value : 01.
 - v) **Auto Pin Mode**
 Description : AutoPin Mode enable or disable. Enable will allow user to gain access by keying in preprogrammed pin numbers only.
 Value : ON, OFF.
 Default value : OFF.

- vi) **Security Off**
Description : Security Mode enable or disable. Disabled will cause the lock to be permanently released.
Value : NO, YES.
Default value : NO.
- vii) **Anti PassBack**
Description : Anti Pass Back Mode Mode enable or disable. Once enabled, the user will not be able to use the same card to gain access through the same direction repeatedly without gaining access on the opposite direction.
Value : ON, OFF.
Default value : OFF.
- viii) **Card Lock Out**
Description : Card Lock Out Mode enable or disable. Once enabled, the user's card will be locked permanently after failure to gain access for three consecutive times. The failure might be caused by wrong pin number, wrong time zone or antipassback violations.
Value : ON, OFF.
Default value : OFF.
- ix) **Tamper**
Description : Tamper Mode enable or disable. Enable will cause the controller to sound the buzzer continuously when it is being opened.
Value : ON, OFF.
Default value : OFF.
- x) **Hi Security Mode**
Description : Select High Security mode for higher security. User can choose from one of the 3 modes for additional security.
Value : Token+Pin(00), Token+Fingerprint(01), Token+Pin+Fingerprint(02).
Default value : 00
- xi) **Hi Security Time Zone**
Description : Determines the verification mode for the door according to the Time Zone.
Value : 00-50
Default value : 00

- xii) **As Exit Reader**
 Description : Reader Direction selection. This setting will enable the user to set the built in reader to become an exit reader and the external reader to become the entry reader.
 Value : ON, OFF.
 Default value : OFF.
- xiii) **Exit Time Zone Enable**
 Description : Exit Reader Time Zone Enable selection. This setting is used to configure the system so that the exit reader will be Time Zone enforced as well. In its default setting, the exit reader will always allow the user to gain exit even though the time zone is incorrect.
 Value : ON, OFF.
 Default value : OFF.
- xiv) **Sounder Period**
 Description : This setting is used to configure the length of time (in seconds) the sounder turn on when triggered.
 Value : 00-99.
 Default value : 00.

Note: Parameter xiv only applicable to XP-GTR series

- xv) **GP Output Mode**
 Description : The GP Output Mode has 3 options can be chosen to trigger the output system.
 [00] – Trigger by the GP Output Tz
 [01] – Trigger by the Sounder Setting
 [02] – Trigger by the O/P Trigger Event
 Value : 00-02.
 Default value : 00.
- xvi) **GP Output Tz**
 Description : Time Zone setting for siren activation. This will determine at which day of the week and what time of the day where the siren will be enabled.
 Value : 00-50.
 Default value : 00.
- xvii) **GP Output Period**
 Description : This setting is used to configure the length of time (in seconds) the siren turn on when triggered.
 Value : 00-99.
 Default value : 00.

Note: Parameter xv, xvi and xvii only applicable to XP-GT Series

xviii) **Fire Release**

Description : Fire Release Enable selection. This setting is connected with the fire alarm system. It is used to configure the system so that the lock will be release while the fire alarm is enable.

Value : NO, YES.

Default value : NO.

xix) **Double Leaf**

Description : Double Leaf Enable selection. This setting is used for double leaf door only. For an example, if the Double Leaf is **[YES]**, both of the door can be opened and it will follow the duration of the Lock Release Time. On the contrary, if the Double Leaf is **[NO]** and the Double Leaf door is not opened at the same time, one of the door will be lock once another door is opened.

Value : NO, YES.

Default value : NO.

3.3 Time Set

Time Set is the time interval setting that defines the activation period of an operation or function. Time Set consists of three intervals of time period that gives the user options to have three time intervals within a single day.

There are 50 Time Sets. Time Set 00 and Time Set 01 are default Time Sets. You can't edit or delete these two Time Sets. Users definable Time Set numbers are from 02 to 49.

The default setting for Time Set 00 and Time Set 01 are as follow:

Time Set 00	From	To
Interval 1	00:00	00:00
Interval 2	00:00	00:00
Interval 3	00:00	00:00

Time Set 01	From	To
Interval 1	00:00	23:59
Interval 2	00:00	00:00
Interval 3	00:00	00:00

Example 1:

During normal office hour, the lock of the company's main door will be released to ease customers going in and out of the door. The door is locked all the time other than office hour.

Normal Office Hour : 08:30 to 17:30
Lunch Hour : 12:00 to 13:00

i.e. the lock will be released from 08:30 to 12:00 and from 13:00 to 17:30.

The sample Time Set is as below:

Time Set 02	From	To
Interval 1	08:30	12:00
Interval 2	13:00	17:30
Interval 3	00:00	00:00

The Time Set above defines the time interval that the lock will be released.

The Time Set can't be used directly to control the Auto Lock Release function. It has to be attached in Time Zone before assigning the Time Zone to Auto Lock Release function.

The diagram below shows the relationship between Time Set and Time Zone:



Example functions are Auto Lock Release, Card+PIN, Exit Button, AutoPIN and Door Access.

More detailed description of Time Zone will be discussed later in this manual.

Example 2:

During normal office hour, users only need to use their cards to access the store room door. After office hour, all staffs require to use Card+PIN to access the door.

Normal Office Hour : 08:30 to 17:30
Lunch Hour : 12:00 to 13:00

i.e. The time intervals for the door to operate in Card+PIN Mode is as follow:

- 00:00 to 08:29
- 12:01 to 12:59
- 17:31 to 23:59

The Time Set will be set as follow:

Time Set 03	From	To
Interval 1	00:00	08:29
Interval 2	12:01	12:59
Interval 3	17:31	05:59

For this case, there is no reusable Time Set. User needs to create another new Time Set for this function. In this case, we have created Time Set 03.

Always remember, Time Set defines the time intervals which, you want certain function to be activated. As you can see, we need to use all three intervals for this Time Set.

To edit the Time Set setting, please follow steps below:

1. Enter Programming.
2. Press '1' for System Menu.
3. Press '3' for Time Set. The screen as below will be shown:

Time Set Setting

Enter Time Set Number
(Min = 02, Max = 49)

[00]

√ - OK X - Cancel

4. Enter two digits Time Set number that you want to set. The screen as below will be shown.

Time Set Setting	
TimeSet No 02	
11 (00): 00 ▶	00 : 00
12 00 : 00 ▶	00 : 00
13 00 : 00 ▶	00 : 00
√ - OK	X - Cancel

5. The field on the left is the 'From' field and the field on the right is 'To' field. Enter four digits value that correspond to HHMM at each field. Press '√' to accept the value displayed at the field in focus.
6. After setting the first interval, the screen will prompt for second and third intervals respectively.
7. When finished setting the time for all three intervals, the screen as shown will prompt user to save changes.

Time Set Setting	
Save Changes? 	
√ - OK	X - Cancel

1. Press '√' to confirm saving changes and return to Set TimeSet menu.
2. You can continue doing setting for other Time Set number or you can press 'X' to return to System menu.

Tips: For functions that require the same time intervals, existing Time Sets can be reused.

3.4 Time Zone

Time Zone can be considered as the grouping of Time Set for 7 days a week plus a holiday. Each individual day of a Time Zone can have different Time Set.

device has 50 sets of Time Zone. Time Zone 00 and Time Zone 01 are defaults Time Zone. They can't be deleted nor edited. Users definable Time Zone numbers are from 02 to 49.

The default setting for Time Zone 00 and Time Zone 01 are as follow:

Time Zone #	Sun	Mon	Tue	Wed	Thu	Fri	Sat	Hol
Time Zone 00	00	00	00	00	00	00	00	00
Time Zone 01	01	01	01	01	01	01	01	01

← Time Set numbers →

Time Zone 00 has all Time Set 00 for everyday in the group and the interval for Time Set 00 is 00:00 to 00:00, that means no time interval. This Time Set is also known as No Access Time Zone. The functions that has been assigned this Time Zone will be disabled 24 hours a day, 7 days a week including holiday.

Time Zone 01 has all Time Set 01 for everyday in the group and the interval for Time Set 01 is 00:00 to 23:59, that means the time interval is 24 hours. This Time Set is also known as Free Access Time Zone. The functions that has been assigned this Time Zone will be enabled 24 hours a day, 7 days a week including a holiday.

Example 1:

During normal office hour, the lock of the company's main door will be released to ease customers going in and out of the door. The door is locked all the time other than office hour including Saturday, Sunday and Holiday.

i.e. The lock will be auto released at time as below:

- Mon – Fri : 08:30 to 12:00 and 13:00 to 17:30 (Time Set 02)
- Sun, Sat and Hol : No auto lock release the whole day (Time Set 00)

The Time Zone should be configured as below:

Time Zone #	Sun	Mon	Tue	Wed	Thu	Fri	Sat	Hol
Time Zone 02	00	02	02	02	02	02	00	00

← Time Set numbers →

(refer to Example 1 in Time Set setting for detailed information of the Time Set)

After creating Time Zone 02, it needs to be assigned to Auto Lock Release TZ setting in Door Parameter menu.

Example 2:

During normal office hour, users only need to use their cards to access the store room door. After office hour, all staffs require to use Card+PIN to access the door.

Due to long Friday Prayer period, the management decided that the door should operate in Card+PIN mode the whole day on Friday as well.

Normal Office Hour : 08:30 to 17:30
Lunch Hour : 12:00 to 13:00

i.e. The time for the door to operate in Card+PIN Mode is as follow:

- Mon – Thu : 00:00 to 08:29, 12:01 to 12:59 and 17:31 to 23:59 (Time Set 03)
- Fri, Sat, Sun and Hol : Card+PIN operation whole day (Time Set 01)

Time Zone #	Sun	Mon	Tue	Wed	Thu	Fri	Sat	Hol
Time Zone 03	01	03	03	03	03	01	01	01

←----- Time Set numbers -----→

(refer to Example 2 in Time Set setting for detailed information of the Time Set)

After creating Time Zone 03, it needs to be assigned to Card+PIN TZ setting in Door Parameter menu.

To edit the Time Zone setting, please follow steps below:

1. Enter Programming.
2. Press '1' for System Menu.
3. Press '4' for Time Zone. The screen as below will be shown:

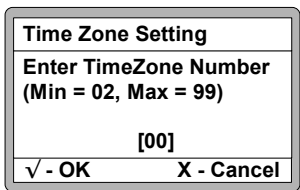

4. Enter two digits Time Zone number that you want to set. The screen as below will be shown.

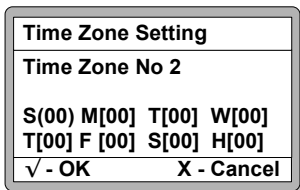

5. Enter two digits Time Set number in the field that you wish to use for Sunday and the press '↓' to continue setting for Monday and so on.
6. The device will cycle in day sequence as below everytime a '↓' is pressed.
7. Sun – Mon – Tue – Wed – Thu – Fri – Sat – Hol
8. When finished setting the Time Set numbers for all the day, the screen as shown will prompt user to save changes.

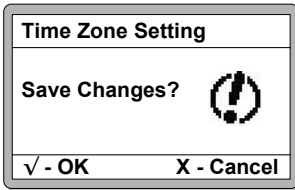

9. Press '√' to confirm saving changes and return to Set TimeZone menu.
10. You can continue doing setting for other Time Zone number or you can press 'X' to return to System menu.

Tips: Functions that require the same Time Zone can reuse Time Zones already created.

3.5 Holiday Setting

Holiday setting is used to define dates that are declared as holidays. device has 30 sets of Holiday setting.

When a date falls into holiday, its original Time Set setting in the Time Zone will be overridden by the Holiday Time Set setting in the same Time Zone.

Example

Supposed 01 Jan falls on Thursday and the Time Set number for Thursday is 02. But because 01 Jan is a holiday, the Time Set number is overridden by Holiday Time Set number, which in this case is 00.

All functions that utilized this particular Time Zone will operate according to Holiday Time Set setting on holiday.

To edit the Holiday setting, please follow steps below:

1. Enter Programming.
2. Press '1' for System Menu.
3. Press '5' for Holiday Sets. The screen as below will be shown. Enter two digits Holiday number (from 00 to 29) that you want to set. Press '√' to confirm. The screen as below will be shown.

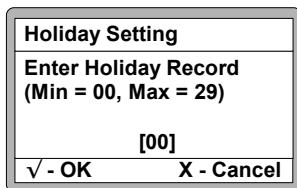

Holiday Setting	
Holiday No 05	
Day (00) Month [00]	
√ - OK	X - Cancel

1. Enter two digits value for Day. Press '↓' to move the field to the Month field.
2. Enter two digits value for Month and press '√'. A screen as below will be shown.

Holiday Setting	
Save Changes? 	
√ - OK	X - Cancel

3. Press '√' to confirm saving changes. You will automatically be redirected back to the System Menu.
4. Note that the holiday date configurations does not have a year setting and therefore these settings must be renewed every year for holidays that does not fall on the same date every year.

3.6 General Parameter

This menu lets you set some general parameters of device. The settings can be done here are:

- i. Address setting
- ii. Communication Mode
- iii. Facility Code
- iv. System Mode

To edit the General Parameter setting, please follow steps below:

1. Enter Programming.
2. Press '1' for System menu.
3. Press '6' for General Parameter. This will bring us to the General Parameter Setting screen.

General Parameter	
▶System Address	00
Advance Comm	OFF
Facility Code	0000
System Mode	DA
√ - OK	X - Cancel

4. Use the '↑' and '↓' buttons to navigate the menu to the desired parameter.
5. Edit the values for the parameter by pressing '√', followed by the desired value and '√' again to confirm.
6. The changes will not be saved if the configuration is interrupted midway.
7. The menu is shown below, with the list of parameters that can be set.
8. User the 'X' button to return to the system menu.
9. You will be prompted to confirm your changes before exiting. Press '√' to confirm changes.

1. List of parameters:

i. System Address

This option lets user change the address setting of the controller. An address is a unique number assigned to the controller in a system to differentiate between controllers. For system that uses direct RS232 connection, the address number must be set to 00. System that has MCI can set addresses starting from 00 up to 15, depends on the number of controllers connected to the system. Enter two digits value for the address setting.

ii. Advance Communication

This option lets user can specify the communication mode between the device and the host of the system. Cycle between the option between '**NOR**' and '**EHD**'. The default value is '**NOR**'.

iii. Facility Code

This option lets user set the four digits Facility Code of the cards to the system. Facility Code is the first four-digit of the 10-digit card number. ie. If a card number is 1234567890, the Facility Code will be '1234' and '567890' is the card number. The default value is '0000'.

iv. System Mode

This option lets the user set the System Operating Mode for the unit. There are two System Mode to choose from and different settings will enable or disable certain features that are only applicable to individual Modes. The two available modes are :

- i. DA – Door Access Mode
- ii. TA – Time Attendance Mode

Below is a list showing the features available and unavailable for each Modes. All features that are not stated here are supported by all Modes.

	Features	Door Access	Time Attendance
1	Number of MASRBU supported	1	0
2	Transaction Buffer full overwrite	No	Yes
3	Transaction Buffer almost full warning	No	Yes
4	Double Clocking	No	Yes

3.7 Network Parameters

This menu allows you to configure your network setting to enable your access control system to be connected to a server. You can set your local IP and Port No. for the device, as well as for the remote server.

The settings which are accessible in this menu are:

- i. Local IP Address
- ii. Local Port Number
- iii. Remote IP Address
- iv. Remote Port Number
- v. Subnet Mask
- vi. Gateway IP
- vii. MAC Address

1. **Local IP Address** - The Local IP Address is the IP address assigned to the controller. It should be unique in the entire network, to ensure communication between the console and the server. To enter the Local IP Address setting, please follow steps below:
 1. Enter Programming.
 2. Press '1' for System menu.
 3. Press '7' for Network Settings. This will bring you to the following screen. This screen will allow the user to enter the IP Address for the device console. After entering the Local IP Address, press '√' to save the changes and proceed to the next screen.

Network Settings	
Enter Local IP Addr.	
(192).[168].[001].[023]	
√ - OK	X - Cancel

1. This screen will allow the user to enter the Local Port No. for the device console. After entering in the Local Port No., press '√' to save the changes and proceed to the next screen.

Network Settings	
Enter Local Port No	
Port No.: (6268)	
√ - OK	X - Cancel

1. This screen will allow the user to enter the IP Address for the remote server. After entering the IP Address of the remote server, press '√' to save the changes and proceed to the next screen.

Network Settings	
Enter Remote IP Addr.	
(192).[168].[001].[100]	
√ - OK	X - Cancel

2. This screen will allow the user to enter the Remote Port No. for the remote server. After entering in the Remote Port No., press '√' to save the changes and proceed to the next screen.

Network Settings	
Enter Remote Port No.	
Port No.: (6268)	
√ - OK	X - Cancel

3. This screen will allow the user to enter the Subnet Mask for the network. After entering in the Subnet Mask, press '√' to save the changes and proceed to the next screen.

Network Settings	
Enter Subnet Mask	
(255).[255].[255].[000]	
√ - OK	X - Cancel

4. This screen will allow the user to enter the Gateway IP for the network. After entering in the Gateway IP, press '√' to save the changes and proceed to the next screen.

Network Settings	
Enter Gateway	
(192).[168].[001].[001]	
√ - OK	X - Cancel

5. Press '√' to confirm saving changes and return to System Menu.
6. Please note that your changes will only take effect after a restart.

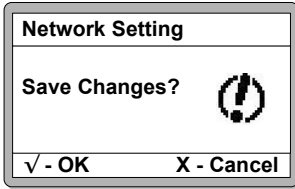

3.8 Sounder Setting

This menu lets user schedule the sounder to activate at certain time of the day. It is able to cater to up to 3 times a day and different configurations can be implemented on different days of the week including the holiday.

To edit the Sounder Setting, please follow steps below:

1. Enter Programming.
2. Press '1' for System menu.
3. Press '7' for Sounder Setting. This will bring user to the Sounder Setting screen. This screen will allow the user to enter a day of the week. Use the '↑' and '↓' buttons to choose a day. After select the day, press '√' to save the changes and proceed to the next screen.

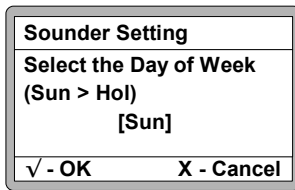

4. This screen will allow user to configure the 3 different times to activate the sounder. Use the '↑' and '↓' buttons to select the Time 00, 01, and 02, then enter the time user want to enable the alarm output. After entering the times, press '√' to save the changes and proceed to the next screen.

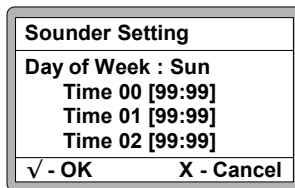

5. Press '√' to confirm saving changes and return to System Menu.

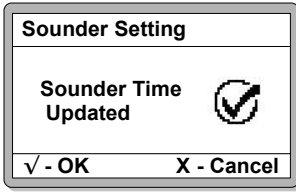

3.9 O/P Trigger Events

This menu allow user decide which event is needed to trigger the alarm output. There are total 62 events, as shown at the table 1, and only 10 events can be selected.

To edit the Sounder Setting, please follow steps below:

1. Enter Programming.
2. Press '1' for System menu.
3. Press '8' for O/P Trigger Events. This will bring you to the following screen. Use the '↑' and '↓' buttons to select the event and press '√' to set the next trigger event. Continue to press '√' key until the 10 events have been gone through. After that, the save page will appear and return to the system menu.

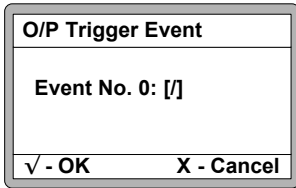

Event Code	Event	Event Code	Event	Event Code	Event	Event Code	Event
0	Valid Entrv Access	G	Door Forced Open	W	Output Isolated	m	Tr m
1	AntiPassBack Violation	H	Card Locked Out	X	Input On	n	Tr n
2	Unknown Card Number	I	Reset Lock Out	Y	Input Off	o	Door Supervisor Off
3	Wrong Facility Code	J	Wrong Time Zone	Z	Change PIN	p	Fire Alarm On
4	Reader Reset	K	Duress Alarm	a	Valid PIN Access	q	Fire Alarm Off
5	Reader Up	L	Door Interlocked	b	Card Disabled	r	Tamper On
6	Reader Down	M	Alarm On	c	Card Enabled	s	Mains Fail
7	Controller Reset	N	Alarm Off	d	Pulse Door Open	t	Mains Normal
8	Enter Proa Mode	O	Door Security	e	Door Open	u	Power Low
9	Exit Proa Mode	P	Alarm Delav Arm St	f	Invalid PIN Access	v	Power Normal
A	Memorv Cleared	Q	Alarm Armed	a	Inactive Card	w	Door Inhibit On
B	Reset Antioassback	R	Alarm Trioaer	h	Card Expired	x	Door Inhibit Off
C	Door Supervisor On	S	Alarm Disarm	i	Valid Exit Access	v	Door Inhibited
D	Wrong PIN/Password	T	Alarm Isolated	i	Cold Start	z	Not Supervisor Door
E	Door Left Open	U	Output On	k	Door Security On		
F	Door Closed	V	Output Off	l	Door Security Off		

Table 1 is shown that the 62 event that able to use to trigger the output.

4. Database Menu

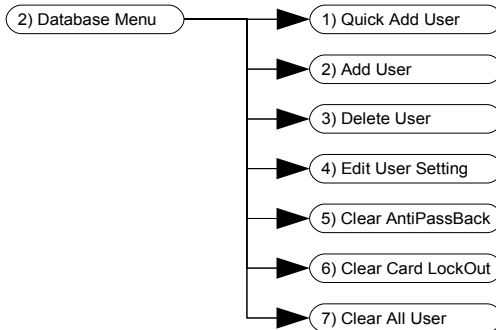

The second item in the programming menu is the Database Menu. The functions that can be performed within this menu are Quick Add User, Add User, Delete User and Edit User Setting. This menu also allows user to clear cards status such as AntiPassBack status, Card Lockout status and also Clear All User.

4.1 Quick Add User

This Menu allows you to quickly add a user by entering only the basic information, such as the User Type and ID. Detailed information can be edited later through the "Edit User Setting" menu.

To Quick Add a User setting, please follow steps below:

1. Enter Programming.
2. Press '2' for Database menu.
3. Press '1' for Quick Add User. This will bring us to the Quick Add User screen.

Quick Add User	
Enter User Type	
User Type :[0]	
Prox Card	
√ - OK	X - Cancel

Select the user type in this screen. They 4 available options are:

- i. [0] for Prox Card
- ii. [1] for ID No.
- iii. [2] for Mifare (Contactless Smart Card)
- iv. [3] for MyKad

Press '√' to accept and proceed to the next screen.

4. Enter the User No. in this screen. Press '√' to confirm.

Quick Add User	
Enter User ID	
ID :[000000]	
√ - OK	X - Cancel

5. If the ID entered has not been added before, you will see a success notice as shown below. Enter another User ID to Quick Add another User, or 'X' to return to Database Menu.

Quick Add User	
New User Installed 	
√ - OK	X - Cancel

4.2 Add User

This Menu allows you to add a user with the its complete information, such as the Time Zone, 1:N operation and the specific verification mode.

To Add a User, please follow steps below:

1. Enter Programming.
2. Press '2' for Database menu.
3. Press '2' for Add User. This will bring us to the Add User screen.

Add User	
Enter User Type	
User Type :[0]	
Prox Card	
√ - OK	X - Cancel

Select the user type in this screen. There 4 available options are :

- i. [0] for Prox Card
- ii. [1] for ID No.
- iii. [2] for Mifare (Contactless Smart Card)
- iv. [3] for MyKad

Press '√' to accept and proceed to the next screen.

4. Enter the User ID in this screen. Press '√' to confirm.

Add User	
Enter User Number	
ID : [000000]	
√ - OK	X - Cancel

5. Enter the TimeZone No. for this user. Press '√' to confirm.

Add User	
Enter TimeZone No.	
TimeZone : [00]	
√ - OK	X - Cancel

6. Choose to allow 1:N operation for this user. Press '√' to confirm.

Add User	
Allow 1:N Operation?	
1:N : [No]	
√ - OK	X - Cancel

7. This screen allows you to select the Verification Mode for the user. Enter a number to choose the verification mode. There are 7 modes to choose from:

1. [0] is by door (The verification mode for the user will be according to the current verification mode of the door entered/exited)
2. [1] is by Token only
3. [2] is by Token and Pin
4. [3] is by Token and Fingerprint
5. [4] is by Token, Pin and Fingerprint
6. [5] is by Fingerprint only
7. [6] is by Fingerprint and Pin

Add User	
Enter Verification Mode	
Verification Mode : [0]	
By Door	
√ - OK	X - Cancel

8. A confirmation that the new user is installed will appear as shown in the screen below, should all the information entered is correct and valid. Repeat steps 3 to 7 to add a new user, or press ' X ' to return to Database Menu.

Add User	
New User Installed	
√ - OK	X - Cancel

4.3 Delete User

This Menu allows you to delete an existing user from the database. To delete a user, please follow steps below:

1. Enter Programming.
2. Press '2' for Database menu.
3. Press '3' for Quick Add User. This will bring us to the Delete User screen. Enter the user ID to select the user to be deleted.

Delete User	
Enter User No.	
ID: [000000]	
√ - OK	X - Cancel

4. If the user exists, a confirmation will appear to notify you that the user has been deleted. Enter a new User No. to delete another user, or Press ' X ' to return to Database Menu.

Delete User	
Enter User No.	
ID: [000000]	
User Deleted	
√ - OK	X - Cancel

4.4 Edit User Settings

Every user installed to the system will have default settings. These settings can be changed in this menu. The settings are Time Zone No., Verification Mode, and Default Pin Number.

To edit card settings, please follow steps below:

1. Enter Programming.
2. Press '2' for Database Menu.
3. Press '4' for Edit User Settings. This will bring us to the Edit User Setting screen. Enter the ID of the user which you want to edit. Press '√' to confirm.

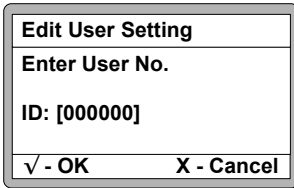

Edit User Setting	
Enter User No.	
ID: [000000]	
√ - OK	X - Cancel

4. This screen allows you to edit the user's TimeZone No. You can select from the TimeZones that you've set earlier in the System Menu. Press '√' to confirm and proceed to the next screen.

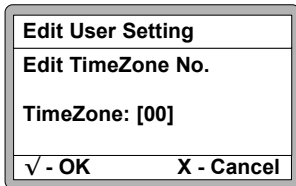

Edit User Setting	
Edit TimeZone No.	
TimeZone: [00]	
√ - OK	X - Cancel

5. This screen allows you to edit the Verification Mode for the user. Enter a number to change the verification mode. There are 7 modes to choose from:
 - i. [0] is by door (The verification mode for the user will be according to the current verification mode of the door entered/exited)
 - ii. [1] by Token only
 - iii. [2] is by Token and Pin
 - iv. [3] is by Token and Fingerprint
 - v. [4] is by Token, Pin and Fingerprint
 - vi. [5] is by Fingerprint only
 - vii. [6] is by Fingerprint and Pin

Press '√' to confirm and proceed to the next screen.

Edit User Setting
Edit Verification Mode Verification Mode: [0]
By Door
√ - OK X - Cancel

- This screen allows you to edit the default Pin No. for the user. All users will have a default pin number of [1234]. Press '√' to confirm after keying in a new Pin No. A confirmation will appear to notify that the user setting has been edited, should all the information entered is correct and valid. Enter another User No. to edit another user setting, or press 'X' to return to Database Menu.

Edit User Setting
Edit Pin No.
Pin No: [1234]
√ - OK X - Cancel

4.5 Clear Anti PassBack

The Clear Anti PassBack menu will let user clear the Anti PassBack status of all users. To Clear Anti PassBack for all users, please follow steps below:

- Enter Programming.
- Press '2' for Database Menu
- Press '5' for Clear Anti PassBack. This will bring us to the Clear Anti PassBack screen. Press '√' to proceed with clearing AntiPassBack.

Clear AntiPassback
Clear AntiPassback?
Press √ to proceed
√ - OK X - Cancel

- This screen will appear when the console is clearing All User's AntiPassBack. A confirmation will be shown once all the AntiPassBack is cleared, and you will automatically be redirected back to the Database Menu.

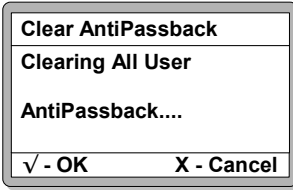

4.6 Clear Card LockOut

The Clear CardLockOut menu will let user clear the Card Lockout status of all the cards. To clear the Card Lockout for all users, please follow steps below:

1. Enter Programming.
2. Press '2' for Database Menu.
3. Press '6' for Clear All Card LockOut. The screen below will be shown. Press '√' to proceed with clearing All Card LockOut.

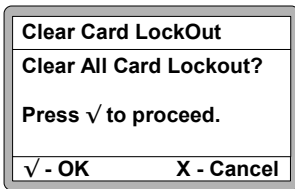

4. This screen will appear when the console is clearing All User's AntiPassBack. A confirmation will be shown once the Card LockOut is cleared, and you will automatically be redirected back to the Database Menu.

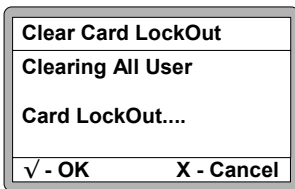

4.7 Clear All User

The Clear All User menu will allow the user to delete **all records** of the User Database. **Warning: This will delete all of the User Data contained in the console. Proceed only if you are sure you want to remove data of all users.**

To Clear All User Data, please follow steps below:

1. Enter Programming.

2. Press '2' for Database Menu.
3. Press '7' for Clear All User. The screen below will be shown. Press '√' to proceed with Clearing All User.

Clear All User	
Delete All Users?	
Press √ to proceed.	
√ - OK	X - Cancel

4. This screen will appear when the console is Clearing All User. A confirmation will be shown once All User is Cleared, and you will automatically be redirected back to the Database Menu.

Clear All User	
Deleting Entire User	
Database....	
√ - OK	X - Cancel

5. Fingerprint Menu

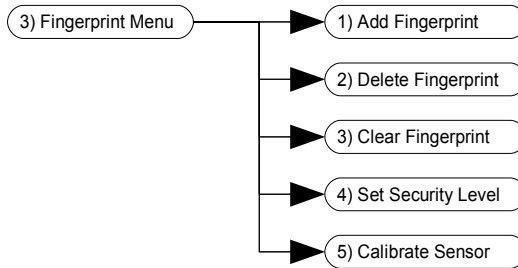

The third item in the programming menu is the Fingerprint Menu. The functions that can be performed within this menu are Add Fingerprint, Delete Fingerprint and Clear Fingerprint. The Security Level of the console can also be set, and the Sensor calibrated in this menu.

Note: All items in the fingerprint menu is only applicable to XP-GT series of controllers

5.1 Add Fingerprint

This menu lets user add a new user fingerprint into the database. To Add a Fingerprint, please follow steps below:

1. Enter Programming.
2. Press '3' for Fingerprint Menu.
3. Press '1' for Add Fingerprint. The screen below will be shown. Enter the User ID of the user that you would like to add the fingerprint data to. Press '√' to confirm and proceed to the next screen.

Add Fingerprint	
Enter User ID	
ID: [000000]	
√ - OK	X - Cancel

Add Fingerprint	
Enter Template Index	
Template Index :[0]	
√ - OK	X - Cancel

4. Enter the Template Index of the fingerprint. Press '√' to confirm and proceed to the next screen.

Add Fingerprint	
Enter Finger Index	
Finger Index :[1]	
√ - OK	X - Cancel

5. Enter the finger index of the user. You may choose from the number [0] to [9]. The table below shows the finger index representation. Press '√' to confirm and proceed to the next screen.

Finger Index	Finger	Finger Index	Finger
0	R-Thumb	5	L-Thumb
1	R-Index	6	L-Index
2	R-Middle	7	L-Middle
3	R-Ring	8	L-Ring
4	R-Little	9	L-Little

6. This screen will prompt you to place your finger on the sensor surface. Please place your finger on the sensor surface and wait for your finger to be detected.

Add Fingerprint	
Please place finger on the sensor surface.	
√ - OK	X - Cancel

7. Your fingerprint will be enrolled into the database shortly thereafter. A confirmation will be received when your fingerprint is successfully enrolled into the database. Do not remove your finger until the enrolment process is complete. Enter another User ID to add another fingerprint, or press ' X ' to return to the Fingerprint Menu.

Note: You will receive a message informing you that no finger is detected, and operation time out should you fail to place your finger on the sensor within the time limit for detection.

5.2 Delete Fingerprint

This menu lets user delete a user fingerprint from the database. To Add a Fingerprint, please follow steps below:

1. Enter Programming.
2. Press '3' for Fingerprint Menu.
3. Press '2' for Add Fingerprint. The screen below will be shown. Enter the User ID of the user's fingerprint that is to be deleted.

Delete Fingerprint	
Enter User ID	
ID: [000000]	
√ - OK	X - Cancel

4. Select the template index of the user's fingerprint. You will receive a notification to notify you when the template has been deleted. Enter another User ID to delete another fingerprint, or press ' X ' to return to Fingerprint Menu.

Delete Fingerprint	
Enter Template Index	
[?]	
1-5 - Template Index	
0 - All User Template	
√ - OK	X - Cancel

5.3 Clear Fingerprint

This menu lets user delete **all** fingerprints contained in the database. To Clear Fingerprint, please follow steps below.

1. Enter Programming.
2. Press '3' for Fingerprint Menu.
3. Press '3' for Clear Fingerprint. The screen below will be shown. Press '√' to proceed.

Warning: Using this function will delete all the fingerprints in the database. Proceed only if you are sure you want to remove all of the fingerprints.

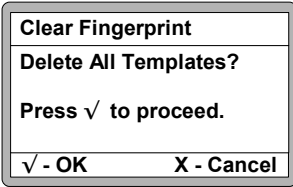

4. You will receive a notification to notify you when all fingerprints have been cleared, and be automatically redirected back to the Fingerprint Menu.

5.4 Template Enrolled

This menu will indicate how many templates are currently being installed in the fingerprint module. When selected, the following screen will be displayed to show the relevant information. To view, please follow steps below:

1. Enter Programming.
2. Press '3' for Fingerprint Menu.
3. Press '4' to view template enrolled. The screen below will be shown.

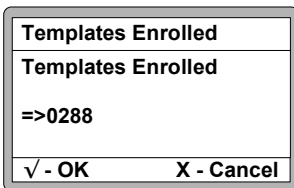

5.5 Set Security Level

This menu lets user set the security level of the Fingerprint Access Control System. To Set Security Level, please follow steps below:

1. Enter Programming.
2. Press '3' for Fingerprint Menu.
3. Press '5' to Set Security Level. The screen below will be shown. Select the security level of preference. The options available are from [0-4]. A higher selection will indicate a higher security level.

Security Level	
Enter Security Level	
Security Level [1]	
√ - OK	X - Cancel

4. Once a security level is selected, press '√' to save. You will receive a notification that the security level has been changed, and automatically be redirected back to the Fingerprint Menu.

Security Level	
Press √ to save.	
Security Level [1]	
√ - OK	X - Cancel

6. Maintenance Menu

The Maintenance Menu consist of several items which are related to the maintenance of the system. These items include function test and also latest information/status of the controller.

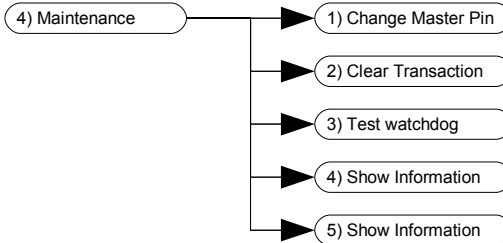

6.1 Master PIN

Master PIN is a six-digit PIN that is used to access the Programming Menu. The default Master PIN is '123456'. To edit the MasterPIN setting, please follow steps below:

1. Enter Programming.
2. Press '4' for Maintenance menu.
3. Press '1' for Master PIN. The screen as below will be shown. Enter the **new** six MasterPIN digits. Press '√' to accept.

Change Master Pin	
Enter New Master Pin	
Pin :[- - - - -]	
√ - OK	X - Cancel

4. Re-enter the **new** six MasterPIN digits. Press '√' to accept.

Change Master Pin	
Re-enter New Master Pin	
Pin :[- - - - -]	
√ - OK	X - Cancel

5. If both set of digits entered are the same, the change will be accepted and a notification will appear to confirm that the MasterPIN is updated.

6.2 Clear Transaction

Clear Transaction lets user clear the whole transactions database in the controller. To clear the transaction database, please follow the steps below:

1. Enter Programming.
2. Press '4' for Maintenance menu.
3. Press '2' for Clear Transaction. The screen as below will be shown:

Clear Transaction	
Confirm to Clear All Transactions?	
Press √ to proceed.	
√ - OK	X - Cancel

4. The transaction database will be cleared. You will be automatically be redirected to the Maintenance Menu.

6.3 Test Watchdog

The test watchdog function is used to test whether the internal watchdog is in good condition. The function of the watchdog is to ensure that the controller is able to exit from a latched condition which might be caused by numerous situations. To perform the Test Watchdog function , please follow steps below:

1. Enter Programming.
2. Press '4' for Maintenance menu.
3. Press '3' for Test Watchdog. The screen as below will be shown:

Test Watchdog	
Confirm to Test Watchdog?	
Press √ to proceed.	
√ - OK	X - Cancel

4. Press the '√' key to proceed with the test. The following screen will be shown. To cancel, just press the 'X' key.

Test Watchdog	
Please wait for Controller to Reset...	
√ - OK	X - Cancel

5. The controller should reset itself in not more than 10 seconds. If it takes longer than that or does not reset at all, then there might be a fault in the unit and should be returned to the manufacturer for further investigation.

6.4 Version

The Version screen will display the firmware version number for the controller and the model number of the controller. To view the Version, please follow steps below.

1. Enter Programming.
2. Press '4' for Maintenance menu.
3. Press '4' for Version. The following screen will be displayed. The screen will return to the Maintenance Menu after 4 seconds.

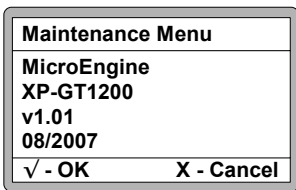

6.5 Information

The Information screen will display the number of card users installed and transactions conducted. To view the Information screen, please follow steps below:

1. Enter Programming.
2. Press '4' for Maintenance menu.
3. Press '5' for Information.
4. The following screen will be displayed. The screen will return to the Maintenance Menu after 4 seconds.

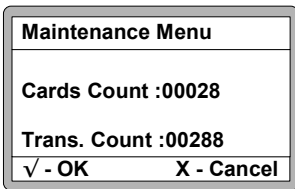

7. Alarm Menu

The last item in the programming menu is the Alarm Menu. This menu is mainly for the setting of alarm panel. Beside that, the output's type, timer, time zone and trigger event can also set by user.

Note: This Alarm Menu only applicable to XP-GTR series.

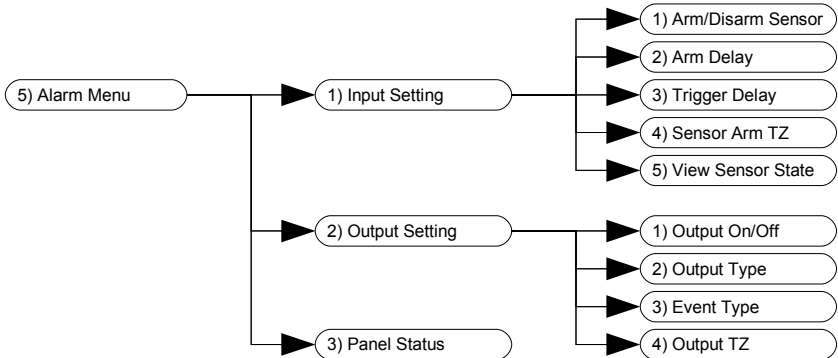

7.1 Input Setting

The Input Setting lets the user to decide which sensor is needed to be activated at which time zone. The user can also set the delay time of the sensor and the alarm at this portion.

In order to set the Input Setting, please follow steps below:

7.1.1 Arm/Disarm Sensor

1. Enter Programming.
2. Press '5' for Alarm Menu.
3. Press '1' for Input Setting.
4. Press '1' for Arm/Disarm Sensor. The following screen will be shown. Press '1' or '2' to select which sensor is needed to be set. Use the '↑' and '↓' buttons to Arm or Disarm the Input and press '√' to updated the setting and back to the Input Setting.

Arm/Disarm Sensor	
Enter Input No.[?] (Min=01, Max=02)	
Status : [Disarm]	
√ - OK	X - Cancel

7.1.2 Arm Delay

1. Enter Programming.
2. Press '5' for Alarm Menu.
3. Press '1' for Input Setting.
4. Press '2' for Arm Delay. The following screen will be shown. Press '1' or '2' to select which sensor is needed to be set. Then press the '#' to confirm and proceed to set the duration of the Arm Delay time. Enter a time setting between '0000' and '3599' second and press '√' to updated the setting and back to the Input Setting.

Arm Delay	
Enter Input No.[?] (Min=01, Max=02)	
Arm Delay: [0000]s	
√ - OK	X - Cancel

7.1.3 Trigger Delay

1. Enter Programming.
2. Press '5' for Alarm Menu.
3. Press '1' for Input Setting.
4. Press '3' for Trigger Delay. The following screen will be shown. Press '1' or '2' to select which sensor is needed to be set. Then press the '#' to confirm and proceed to set the duration of the Trigger Delay time. Enter a time setting between '0000' and '3599' second and press '√' to updated the setting and back to the Input Setting.

Trigger Delay	
Enter Input No.[?] (Min=01, Max=02)	
Trigger Delay: [0000]s	
√ - OK	X - Cancel

7.1.4 Sensor Arm Tz

1. Enter Programming.
2. Press '5' for Alarm Menu.
3. Press '1' for Input Setting.
4. Press '4' for Sensor Arm Time Zone. The following screen will be shown.

Sensor Arm TZ	
Enter Input No.[?] (Min=01, Max=02)	
Arming TZ: [FF]	
√ - OK	X - Cancel

- From this screen, the user can key in '1' or '2' to select which sensor is needed to be set. Then press the '#' to confirm and proceed to set the Time Zone to arm the input sensor. This will determine at which day of the week and what time of the day where the sensor will be enabled. After the Time Zone has been set, then press '√' to updated the setting and back to the Input Setting.

7.1.5 View Sensor State

- Enter Programming.
- Press '5' for Alarm Menu.
- Press '1' for Input Setting.
- Press '5' for View Sensor state. The screen as below will be shown:

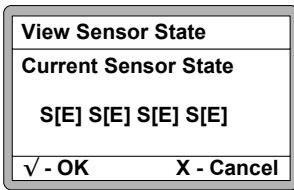

- This screen is shown the status of the sensor. If the input sensor is not connected, the screen will show [E]. Otherwise, If the sensor has connection with the alarm panel, the screen will show [N].

7.2 Output Setting

The output setting is used to enable the alarm output where the user need to activate. User also can set the alarm trigger period, decide which event is needed to trigger the alarm and determine at which day of the week and what time of the day where the alarm will be enabled.

To set the Output Setting, please follow steps below:

7.2.1 Output On/Off

- Enter Programming.
- Press '5' for Alarm Menu.
- Press '2' for Output Setting.
- Press '1' for Output On/Off. The screen as below will be shown. Press a value between '0' to '3' to select which which alarm output is needed to be set. Use the '↑' and '↓' buttons to switch ON or switch OFF the output. Then press '√' to updated the setting and back to the output Setting.

Output On/Off
Switch Output No.[?] (Min=01, Max=04)
Status : [OFF]
√ - OK X - Cancel

7.2.2 Output Type

1. Enter Programming.
2. Press '5' for Alarm Menu.
3. Press '2' for Output Setting.
4. Press '2' for Output Type. The following screen will be shown. Press a value between '0' to '3' to select which alarm output is needed to be set. Then press the '#' to confirm and proceed to set the Output Type. Use the '↑' and '↓' buttons to set the alarm output is activated constantly, **[CONST]**, or pulse, **[PULSE]**. Beside that is timer setting, user can enter a time between '0000' and '3599' second. Then press '√' to updated the setting and back to the output Setting.

Output Type
Switch Output No.[?] (Min=01, Max=04)
Type [Conts][0000]s
√ - OK X - Cancel

7.2.3 Event Type

1. Enter Programming.
2. Press '5' for Alarm Menu.
3. Press '2' for Output Setting.
4. Press '3' for Event Type. The screen as below will be shown. Press a value between '0' to '3' to select which alarm output is needed to be set. Then press the '#' to confirm and proceed to set the Event Type.

Event Type
Switch Output No.[?] (Min=01, Max=04)
Event No.[00 :[/]
√ - OK X - Cancel

5. There are 20 events can be selected from the total 62 events (please refer to pg.29, Table1). Enter a value between '00' to '19' and use the '↑' and '↓' buttons to choose a event from table 1. Then press '√' to updated the setting and back to the output Setting.

7.2.4 Output TZ

1. Enter Programming.
2. Press '5' for Alarm Menu.
3. Press '2' for Output Setting.
4. Press '4' for Output Tz. The screen as below will be shown. Press a value between '0' to '3' to select which alarm output is needed to be set. Then press the '#' to confirm and proceed to set the Time Zone of the alarm output. This will determine at which day of the week and what time of the day where the alarm output will be enabled. Then press '√' to updated the setting and back to the output Setting.

Switch Output No.[?] (Min=01, Max=04)	
Output TZ: [FF]	
√ - OK	X - Cancel

7.3 Panel Status

1. Enter Programming.
2. Press '5' for Alarm Menu.
3. Press '3' for Panel Status. The screen as below will be shown:

Panel Status	
Status [Down]	
√ - OK	X - Cancel

4. This screen is shown that the information about the connection between controller and the alarm panel. If the status is **[UP]**, means that the connection between controller and the alarm panel has communication. If the status is **[DOWN]**, the user need to refer to the wiring diagram and recheck with the wiring connection.

8. Exit Programming Menu

If there is no activity for 30 seconds inside the Programming Menu, device will automatically exit from Programming Menu and return to Idle Mode.

User can also exit the Programming Mode by pressing the ' X ' button at the main programming menu.

Appendix 1 – General Wiring for XP-GT using MAS-RBT

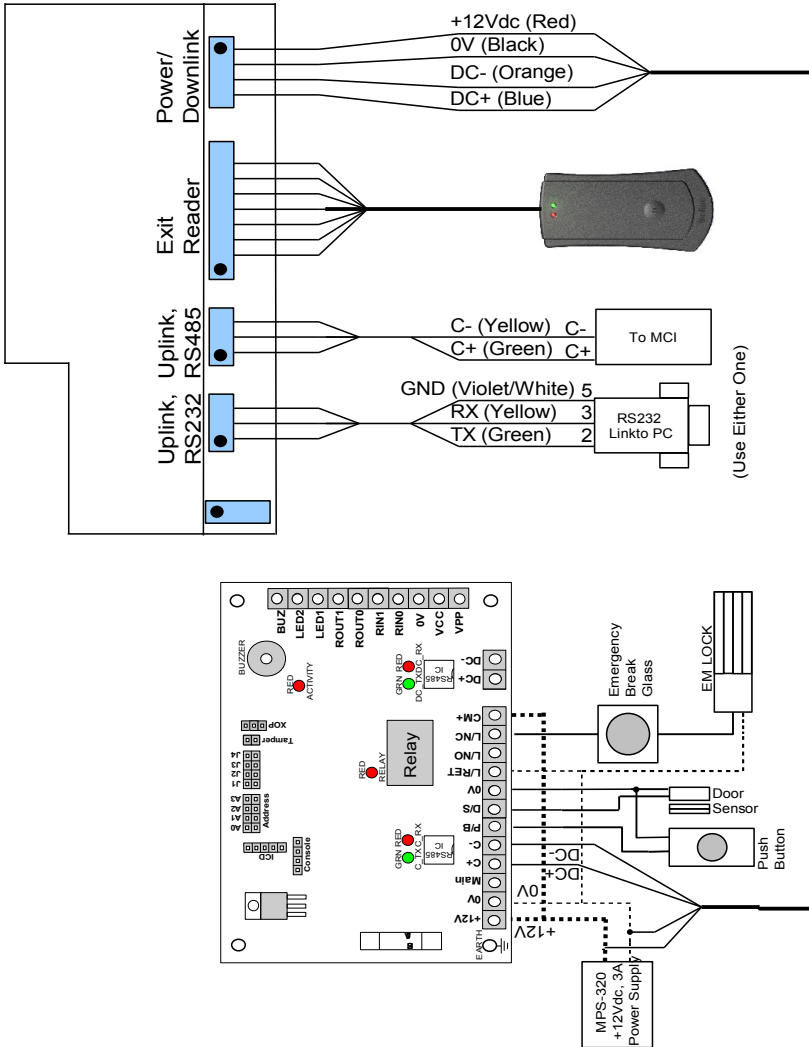

Appendix 2 – General Wiring for XP-GTR using MAS-RBU

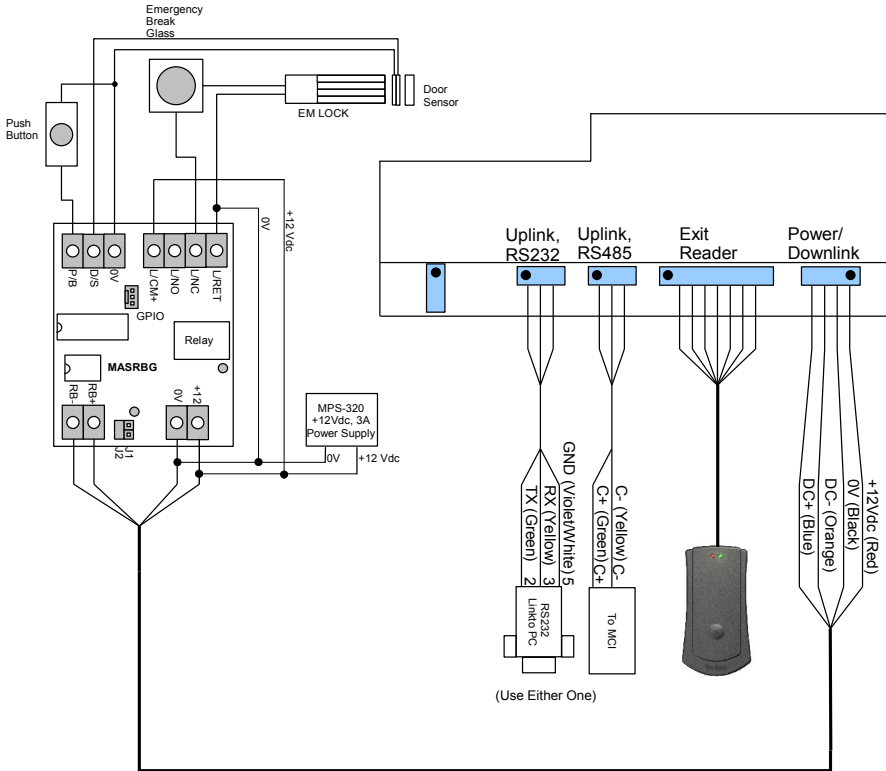

Appendix 3 – General Wiring for two XP-GT using MAS-RBT

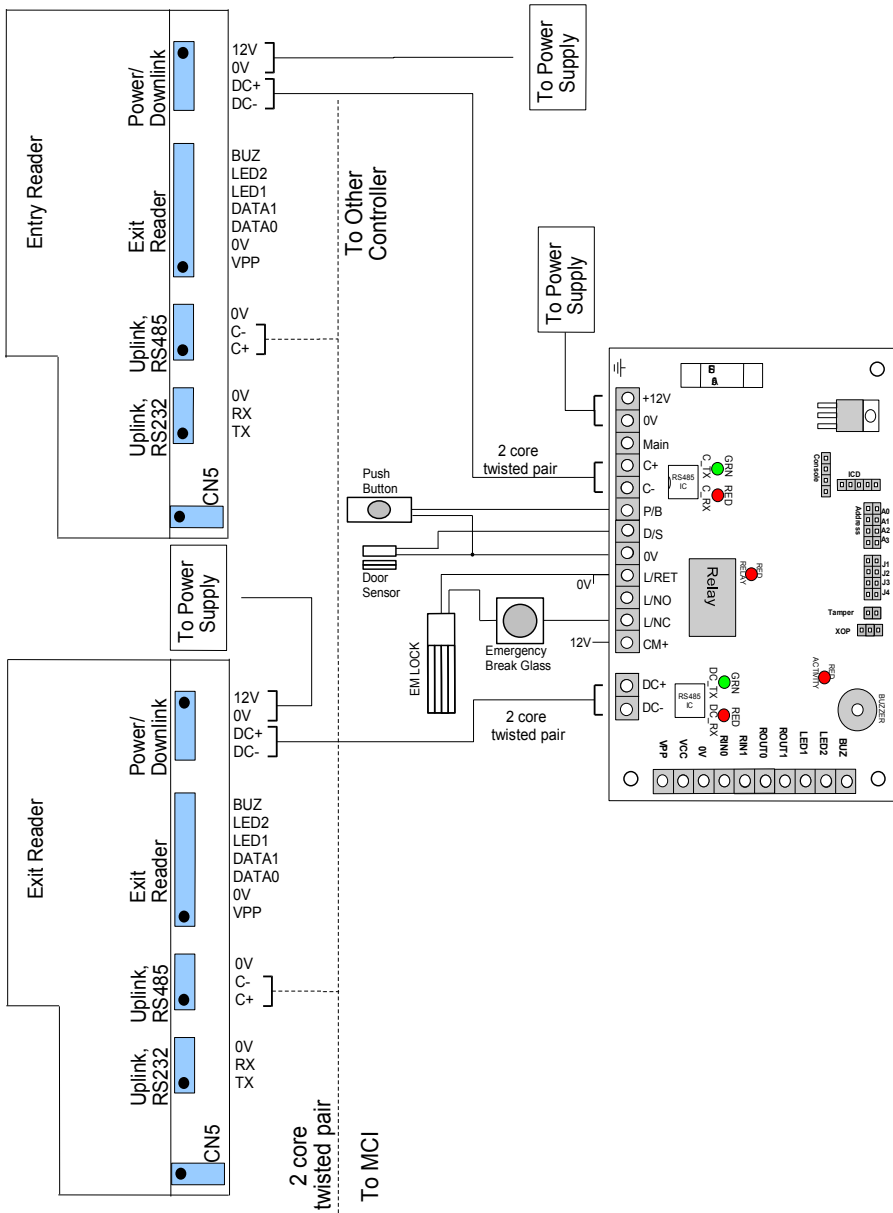

Appendix 4 - Connection for XP-GT using sounder feature

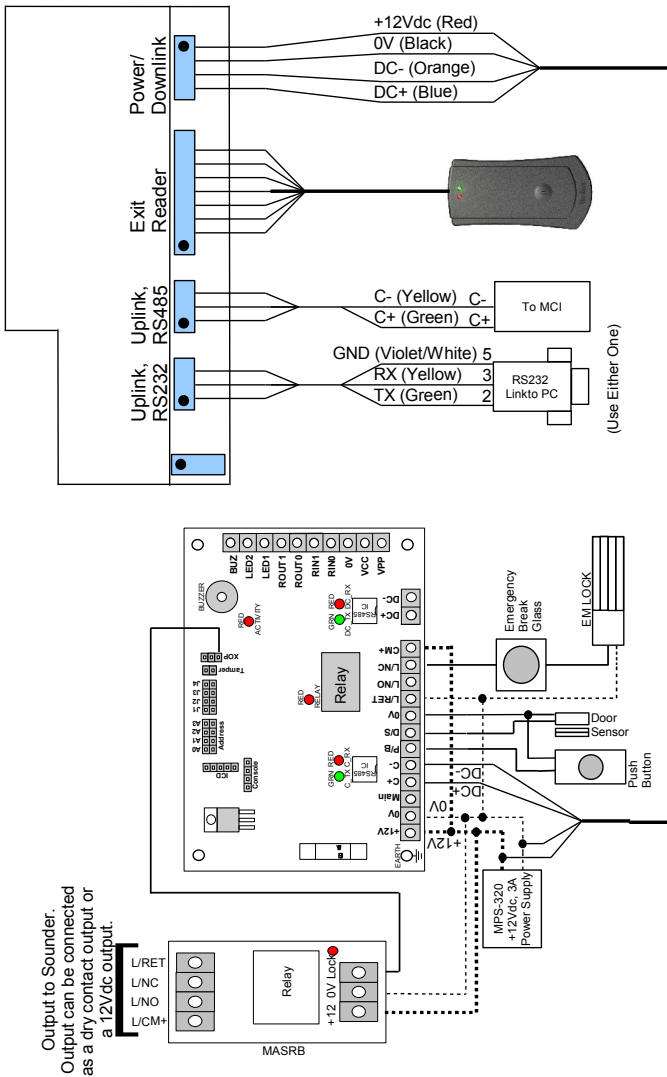

Appendix 5 - Connection for XP-GT using sounder feature

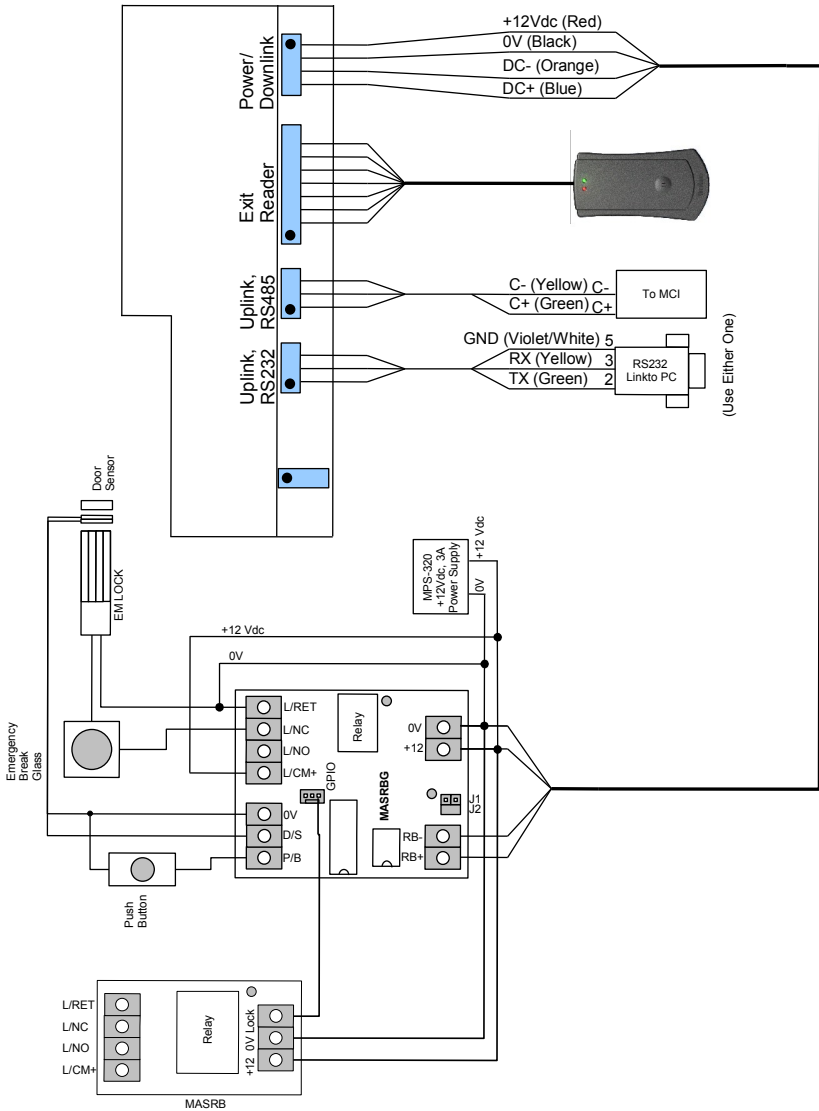

Appendix 6 - Connection for XP-GT and XP-GTR using fire release feature

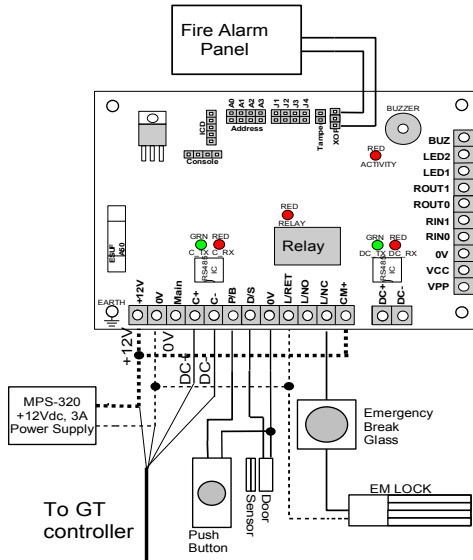

Connection for XP-GT controller using fire release feature

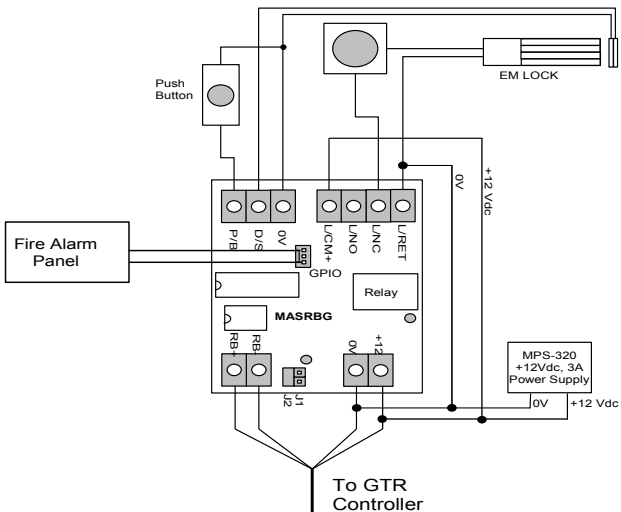

Connection for XP-GTR controller using fire release feature

Appendix 7 - Connection for XP-GTR to MIO44

