

## BRD02 Traffic Detector

WWW.MAG.COM.MY



### Description

BRD02 is a traffic detector that adopts 24-24.25GHz Frequency Modulated Continuous Wave (FMCW) and high-speed digital signal processing technology to calculate the target distance by calculating the frequency difference between the received echo frequency and the transmission frequency. After logical operation, it performs external control and data transmission.

It is suitable for vehicle monitoring and controlling the opening and closing of barrier gate for smooth parking access.

### Features

- Better accuracy.** Traffic detector adopts 24-24.25GHz Frequency Modulated Continuous Wave (FMCW) and high-speed digital signal processing technology to calculate the target distance by calculating the frequency difference between the received echo frequency and the transmission frequency whereas loop detector using inductance loop coil.
- Easier installation.** Can be easily mounted on the body of barrier gate without requires ground/road surface cut and complicated wiring work. User friendly one button quick parameters setting that allow users to set detection range, distinguish mode and sensitivity level. Default setting is 2.5m detection range, doesn't distinguish and low sensitivity level.
- Long lasting and weatherproof.** The traffic detector have strong environmental adaptability with IP67 where it can withstand of dust, sunlight and raining. It works in range of 24-24.25Ghz without effects from any climatic environment. It can last longer and requires minimum maintenance. Thus, save you time and cost in long term.
- Intelligent detection.** Can effectively distinguish vehicles and humans to avoid any hitting whereas loop detector can only detect metal objects/ vehicle.
- Extended functionality.** It can be used to trigger detection, for example trigger camera to capture the picture or trigger the alarm in the warning zone. Can record the traffic and no data is lost when power is off.

## Technical Parameters

Input Voltage	DC12V, 150mA
Working Frequency	24-24.25GHz
Modulation Mode	FMCW
Sending Power	10-15dBm
Detection Distance	1 - 6 meters, $\pm 0.2$ meters
Working Temperature	-40°C~+85°C
Protection Level	IP67
Dimension(L*W*H)	115mm (L) x 95mm (W) x 25mm (H)

### BRD02 wave shape

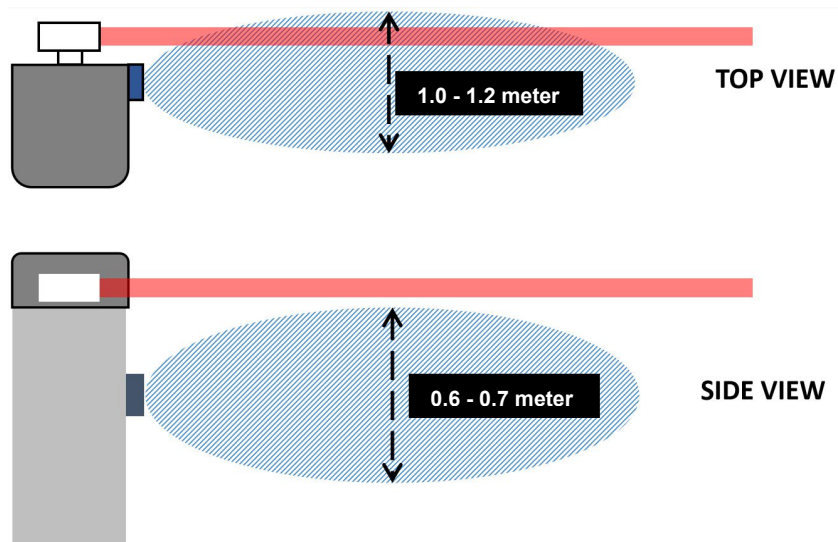

### Default detection range

Suggested to maintain default detection range 2.5m which is sufficient to accurately detect typical vehicle within 4m barrier arm

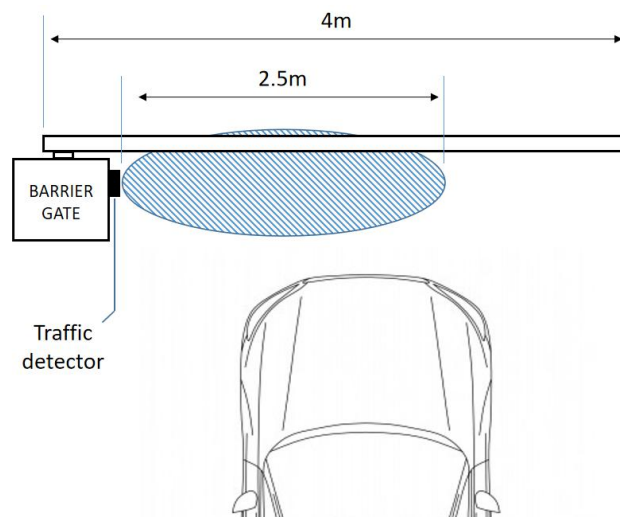

## Dimension

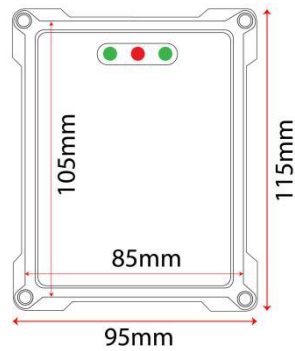

## Installation guide

### Recommended installation height

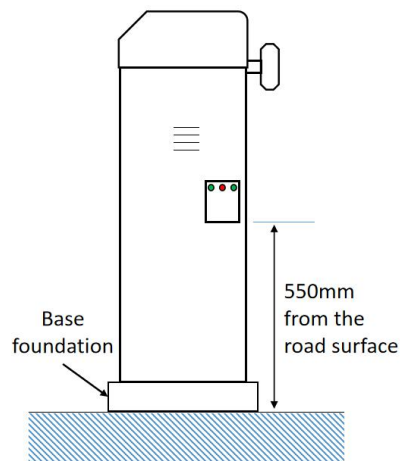

### Special installation height

For higher base foundation, traffic detector location must be in the middle between the road surface and below the barrier gate arm. Sensitivity must be set to high.

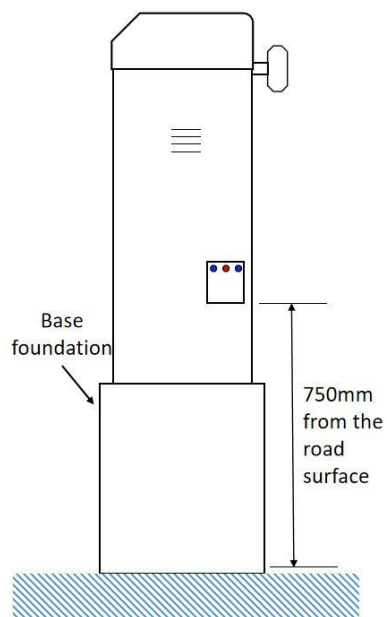

Correct detection setting

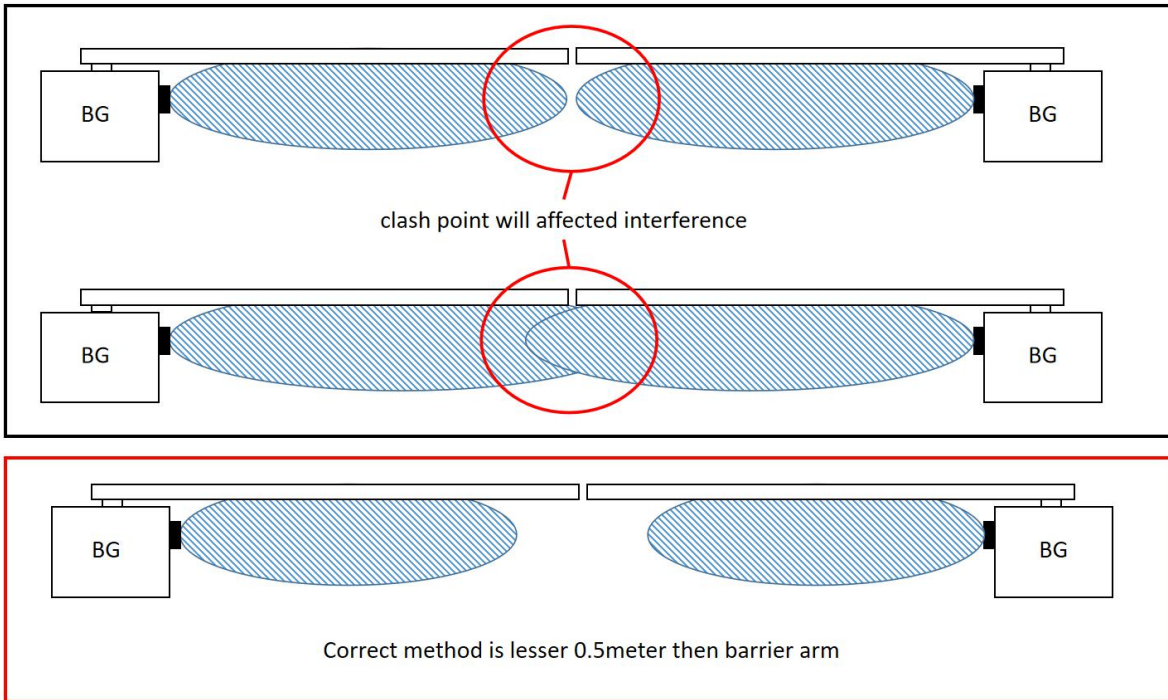

**Pre-caution**

Narrow junction road

For cases where vehicle lane that leading to a narrow junction, traffic detector will miss detect if vehicle enter or exit at 30° angle. This might cause the barrier arm come down even though the vehicle have not fully pass through.

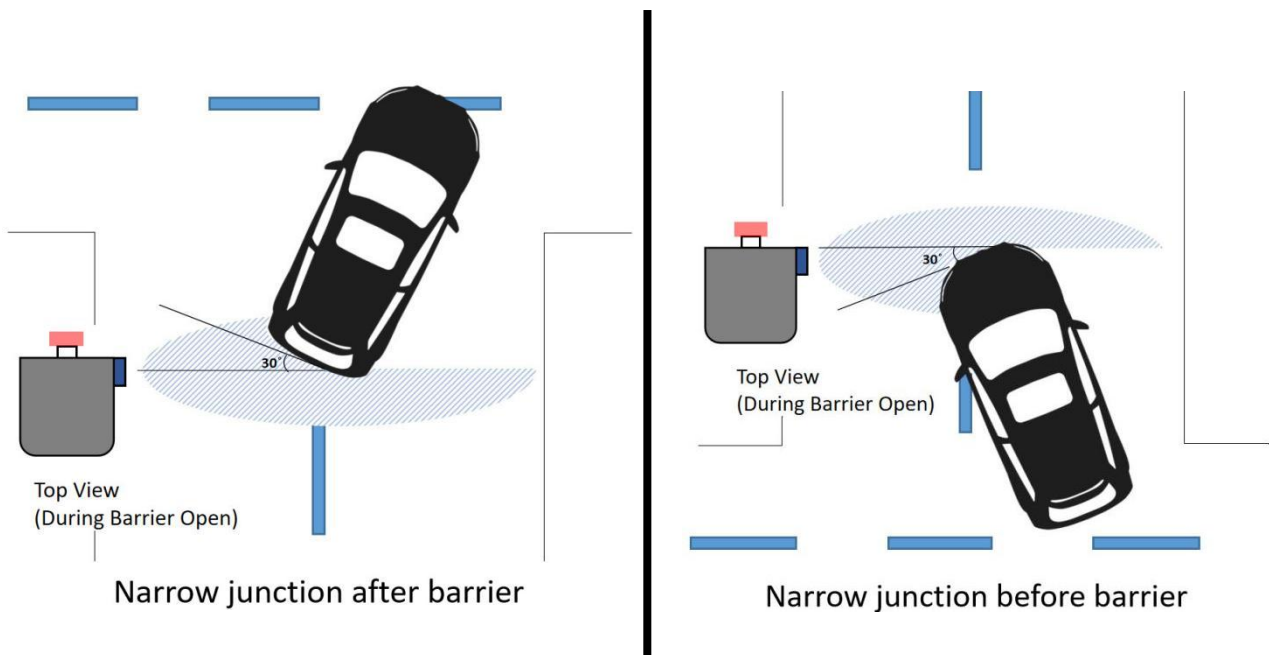

**Solution :** Traffic detector is recommended to install separately onto a metal pole. Metal pole should be 60cm away from barrier gate to prevent miss detection.

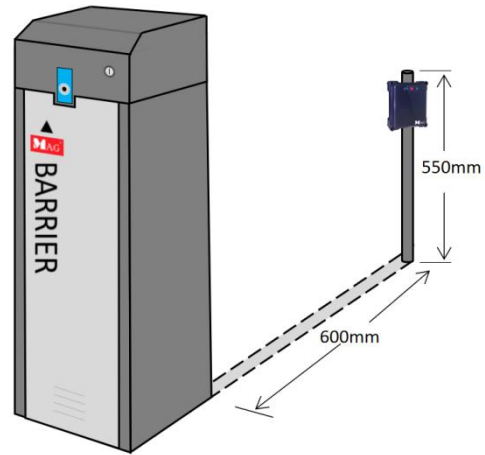
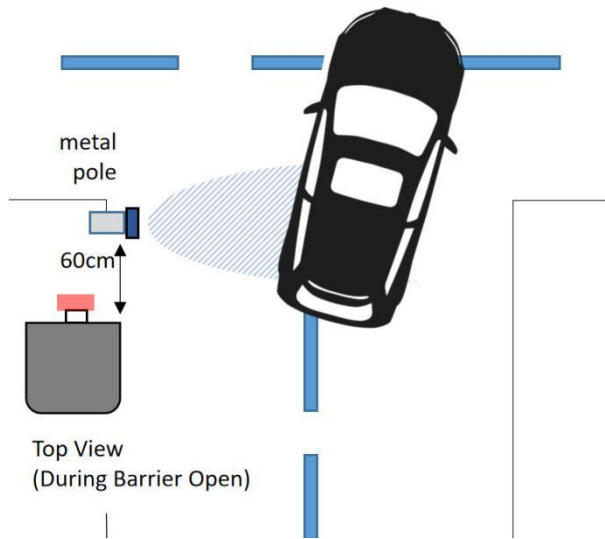

Example traffic detector install separately on a metal pole

Trigger mode for long range reader

For trigger mode scenario, BRD02 is recommended to install at a separate metal pole that 2000mm to 3000mm away from long range access card reader metal pole.

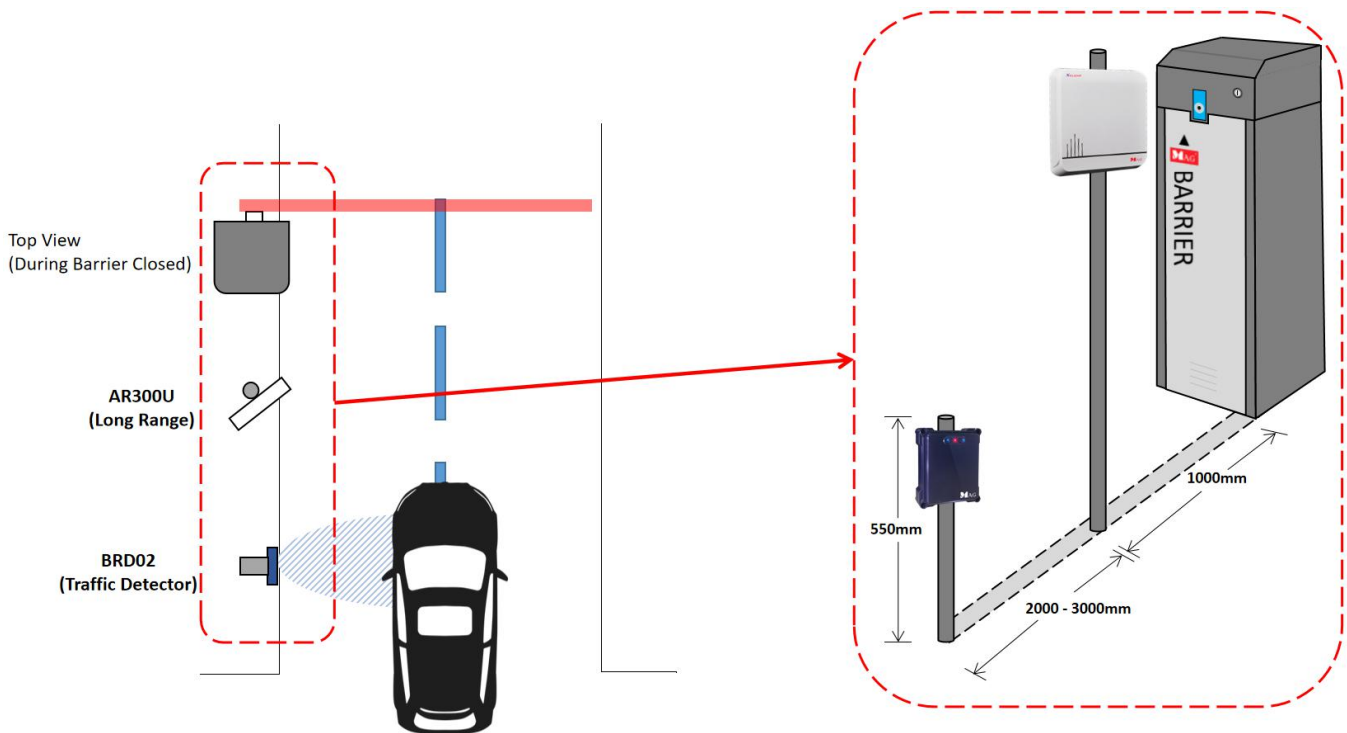

\*For more information please refer to our BRD02 traffic detector full installation manual.

\*Product performances is based on testing in a controlled environment. Your result may vary due to several external and environment factors.



© COPYRIGHT 2021. This documentation served as a reference only. It is subject to change without further notice. All the diagrams and information in this documentation may not be duplicated or modified in any form without the written approval from the management.

© 2021 SP V3 BRD02