

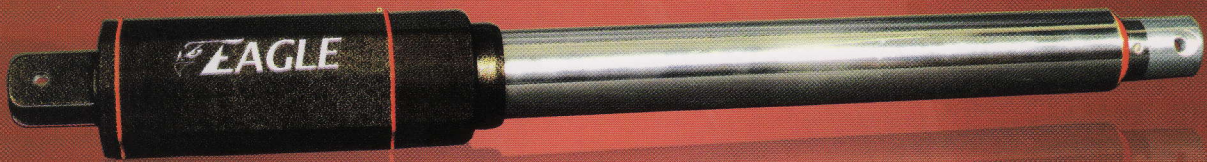

 **EAGLE**



*For Swing & Folding Gate*

Powerful • Reliable • Safety

*Auto Gate System  
Make Life Simple*

## DIMENSION GUIDE TO INSTALL A FOLDING GATE

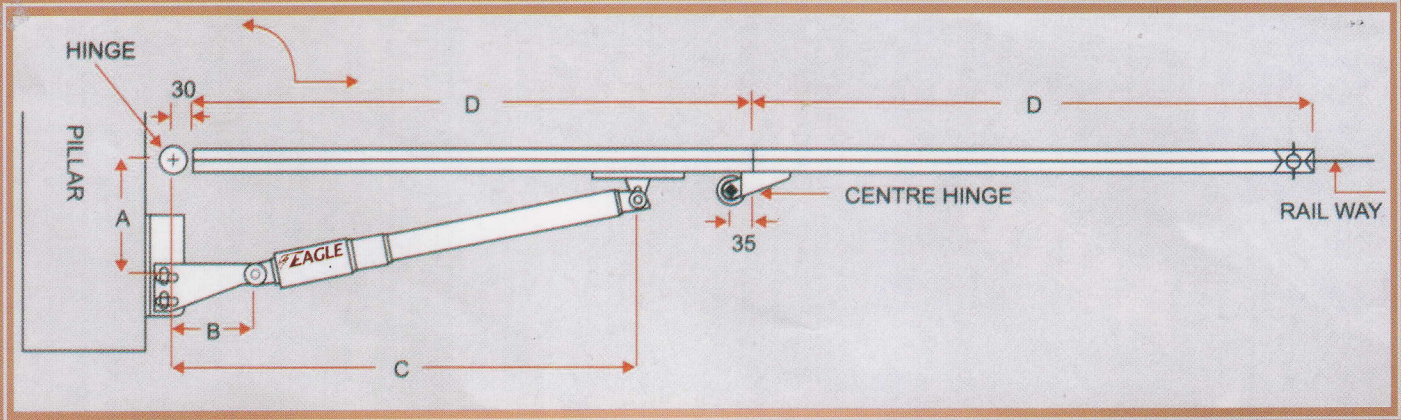

## DIMENSION GUIDE TO INSTALL A SWING GATE

<b>A</b>	165mm ~ 180mm
<b>B</b>	128mm ~ 140mm
<b>C</b>	816mm ~ 837mm
<b>D</b>	Min 1000mm

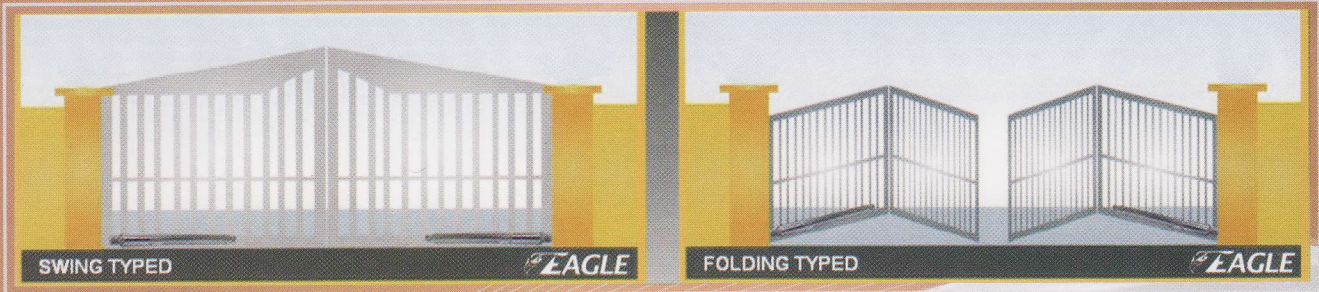
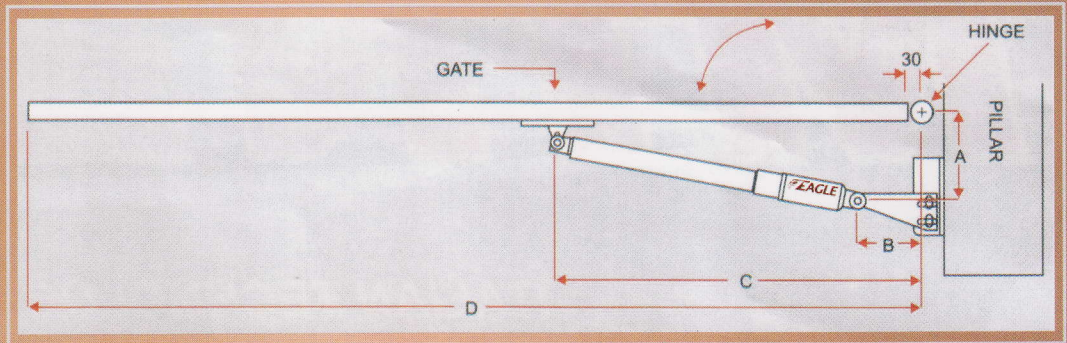

## TECHNICAL SPECIFICATIONS:

<b>MODEL</b>	GT680
<b>OPERATING VOLTAGE</b>	24VDC for normal speed 12VDC for cushioning speed
<b>DRIVING METHOD</b>	4 starts screw driven piston typed
<b>MAX. PISTON DISPLACE</b>	320mm
<b>PISTON SPEED</b>	28mm / sec.
<b>GEAR BOX</b>	Three stages planetary reducer
<b>MAX. LENGTH OF GATE</b>	5 meters per wing
<b>MAX. WEIGHT OF GATE</b>	400Kgs. per wing
<b>SAFETY CLUTH</b>	Electronic controller current sensing
<b>CONTROLLER DEVICE</b>	Micro-computer based
<b>BACK-UP BATTERY</b>	12V 7AH Rechargeable
<b>AMBIENT TEMPERATURE</b>	0 to 80°C