



Professional Public Address System

100W EMV Series Volume Control

ATTENUATOR
www.emix.com.my



The **Emix** series Volume Control intended for Public Address application with the options of 5 watts, 10 watts, 25 watts, 50 watts and 100 watts type, where the size is equivalent to MK 1 gang plate.

The panel is made of high impact ABS plastic with white based polycarbonate facial and reverse silkscreen of black colour wordings and symbol. And the mounting screws are not visible on the panel after installation.

Adjusting of the volume is via the rotary knob that allows 6 steps of output level attenuation.

Provision of an Emergency Overriding relay (24VDC) allows paging / announcement to bypass the selected volume setting and automatically set the sound output level to the maximum.

Optional: The casing in white colour epoxy powder coated metal box (PAB-000, Weight : 250gm).

TECHNICAL SPECIFICATIONS

Specifications Model	Rated Power (W)	Attenuation		Depth (MM)	Weight (gm) -w/o box -
		Type	Per Step (dB)		
EMV-3005	5	Resistance	3-5	12	100
EMV-3010	10	Inductive	3	40	360
EMV-3025	25	Inductive	3	45	370
EMV-3050	50	Inductive	3	45	375
EMV-3100	100	Inductive	3	48	395

DIMENSION & INSTALLATION

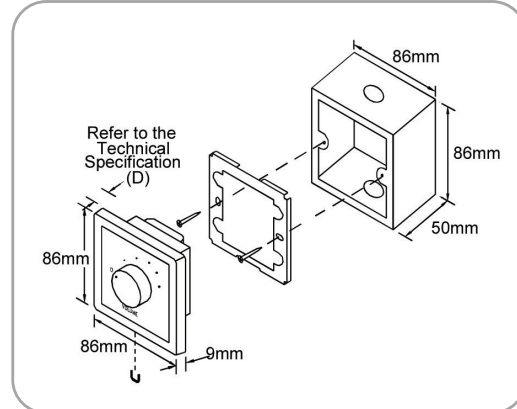

EMV Series 100W Volume Control