

QMCL series

Multiple Color LED Steady Signal Lights



• 7 Color modes available via wiring

You can configure seven color signals by combining the 4 signal wires (red, green, blue, black) attached to the warning light.

Multi-Color Warning Light with Seven Color Options

• Emits a cozy and comfortable hue

QMCL series signal lights have a milky translucent hue when turned on. These signal lights provide a comfortable and stable viewing condition for workers in close proximity.



Common Specifications(QMCL60/ QMCL80/ QMCL100/ QMCL125)

- Helps reduce the costs of installation by reducing the space needed to emit seven color signals in a single warning light
- Milky translucent color when off, the soft LED illuminates designated color when on
- Built-in buzzer available (Volume : Max 80dB at 1m)
- Materials : Lens-AS, Body-ABS
- Ambient operating temperature : -30°C to +50°C
- Protection rating : IP65
- Certificates : CE Compliant
- Compliant with RoHS directive



QMCL60



QMCL80

QMCL60 Ø60mm Multiple Color LED Steady Signal Light

Model number	Voltage	Current	Certificates	Weight	Color
QMCL60	DC12V	0.120A	CE	0.12kg	7 Colors
	DC24V	0.060A		0.12kg	

QMCL80 Ø80mm Multiple Color LED Steady Signal Light

Model number	Voltage	Current	Certificates	Weight	Color
QMCL80	DC12V	0.120A	CE	0.17kg	7 Colors
	DC24V	0.060A		0.17kg	

Technical Diagram (Units : mm)

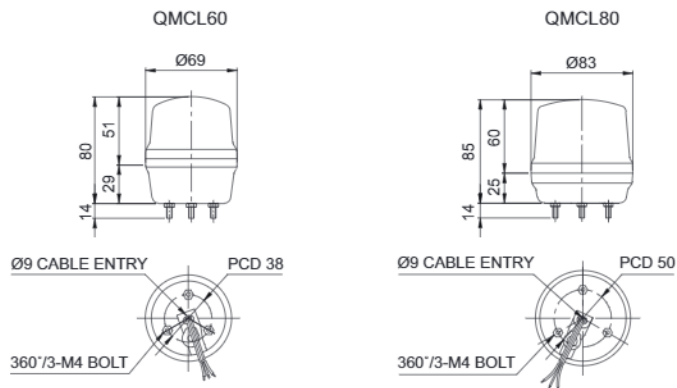

	Voltage	AC/DC12V	AC/DC24V
QMCL60	Signal Line	0.120A	0.060A
QMCL80	Buzzer Line	0.020A	0.020A
QMCL100	Signal Line	0.240A	0.120A
QMCL125	Buzzer Line	0.020A	0.020A



QMCL series



New innovative LED signal light that can be configure with 7 colors in 1 signal lamp



QMCL100



QMCL125



Wiring Instructions

- External signal line standard : Signal line 4P(R,G,B,K) threading, signal line standard UL1007 AWG22(0.3sq) 400mm
- Product can be wired regardless of polarity
- Please refer to Wiring Instructions diagram to properly configure color options



Ordering Specification

QMCL80	BZ	24
[Model number]	[Buzzer option]	[Voltage]
• QMCL60	• None	• 12-DC12V
• QMCL80	• No buzzer	• 24-DC24V
• QMCL100	• BZ	
• QMCL125	• Built-in buzzer	

Multiple Color LED Steady Signal Lights



QMCL100 Ø100mm Multiple Color LED Steady Signal Light

Model number	Voltage	Current	Certificates	Weight	Color
QMCL100	DC12V	0.240A	CE	0.24kg	7 Colors
	DC24V	0.120A		0.24kg	



QMCL125 Ø125mm Multiple Color LED Steady Signal Light

Model number	Voltage	Current	Certificates	Weight	Color
QMCL125	DC12V	0.240A	CE	0.31kg	7 Colors
	DC24V	0.120A		0.31kg	



Technical Diagram

(Units : mm)

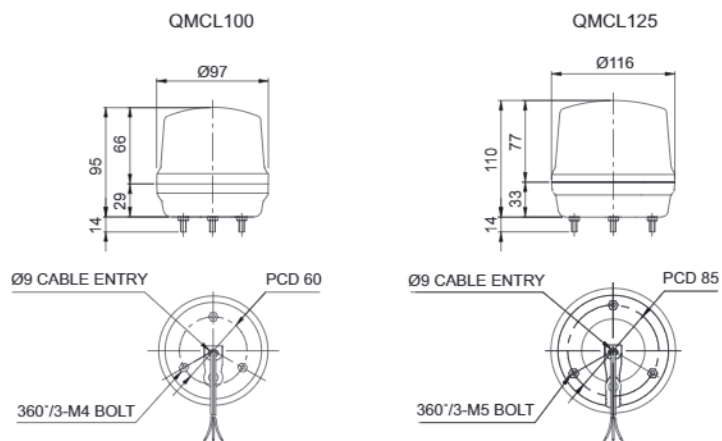

Wiring Instructions

QMCL60/ QMCL80/ QMCL100/ QMCL125-DC

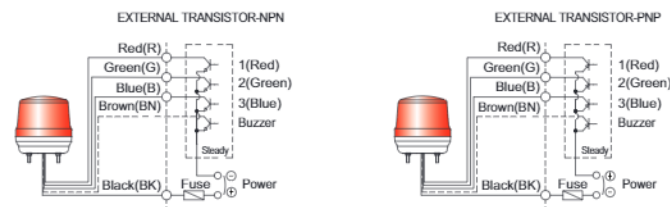
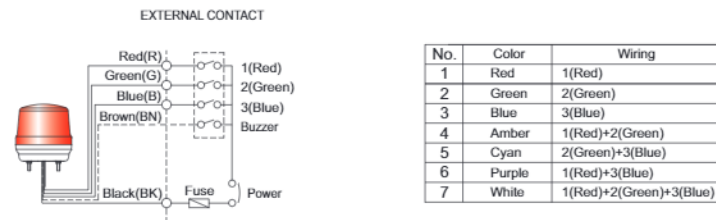

Customization

- Wall mounting bracket options : Bracket structure allows for threading through the bracket hole or into the wall mount

