

SR series

Stackable Warning/ Signal Lights



SR



SRP

Common Specifications(SR/SRL)

- Ø80mm stacked structure
- Multi signal transmissions capable in 1 signal light
- Standard color
 - 1st layered - ● Red
 - 2nd layered - ● Red ● Green
 - 3rd layered - ● Red ● Yellow ● Green
- Materials : Lens-AS, Body-ABS, Reflector-Heat resistant ABS
- Protection rating : IP44

SR/ SRP Bulb Revolving Tower Warning/ Signal Lights

- Adopts a special power transmission system that reduces noise and wear
- 2nd & 3rd stacked lens colors can be changeable except for the top layer lens
- Revolving speed : 120-140RPM
- Ambient operation temperature : -20°C to +50°C

Model number	Layer	Voltage	Current	Bulb			Certificates	Weight	Color
				Spec	Standard	Parts no			
SR SRP	1	DC12V	0.488A	12V5W	T16x35 15S	5	-	0.28kg	● R-Red
		DC24V	0.310A	24V5W	T16x35 15S	6		0.28kg	
		AC110V	0.102A	12V5W	T16x35 15S	5		0.49kg	
		AC220V	0.051A	12V5W	T16x35 15S	5		0.49kg	
	2	DC12V	0.968A	12V5W	T16x35 15S	5		0.53kg	● R-Red ● G-Green
		DC24V	0.620A	24V5W	T16x35 15S	6		0.53kg	
		AC110V	0.146A	12V5W	T16x35 15S	5		0.76kg	
		AC220V	0.073A	12V5W	T16x35 15S	5		0.76kg	
	3	DC12V	1.453A	12V5W	T16x35 15S	5		0.71kg	● R-Red ● A-Amber ● G-Green
		DC24V	0.930A	24V5W	T16x35 15S	6		0.71kg	
		AC110V	0.191A	12V5W	T16x35 15S	5		1.03kg	
		AC220V	0.095A	12V5W	T16x35 15S	5		1.03kg	

Technical Diagram

(Units : mm)

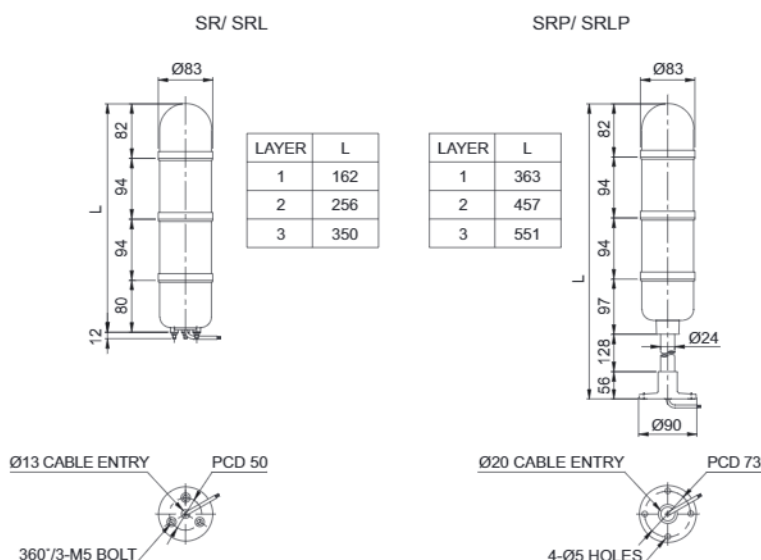

Warning/Signal/Stackable



Signal & Electric Horn/Speakers



Vessels and Heavy-Duty Equipment



Explosion Proof



Warning Light Bar



Aviation Obstruction Lights



Signal Tower Lights



USB/ETN Signal Tower Lights



Wireless Network System



Electric Horn/Speakers



Industrial LED Lights

SR series

Stackable Signal Lights/ Warning Lights



SRL



SRLP

SRL/ SRLP LED Steady/ Flashing Signal Towers

- Qlight's exclusive LED light distribution system with multi-tiered reflector spreads light evenly throughout the surface of the 94mm height special diffusing lens
- Fixed user selected color arrangement
- Flashing rate : 60-80 flashes/min(Built-in switch for selection between steady/ flashing mode)
- Ambient operating temperature : -30°C to +50°C
- Compliant with RoHS directive

Model number	Layer	Voltage	Current	Certificates	Weight	Color
SRL SRLP	1	DC12V	0.123A	-	0.23kg	● R-Red
		DC24V	0.094A		0.23kg	
		AC110V	0.062A		0.45kg	
		AC220V	0.031A		0.45kg	
	2	DC12V	0.246A		0.37kg	● R-Red ● G-Green
		DC24V	0.188A		0.37kg	
		AC110V	0.075A		0.70kg	
		AC220V	0.037A		0.70kg	
	3	DC12V	0.369A		0.53kg	● R-Red ● A-Amber ● G-Green
		DC24V	0.283A		0.53kg	
		AC110V	0.091A		0.89kg	
		AC220V	0.045A		0.89kg	

Wiring Instructions

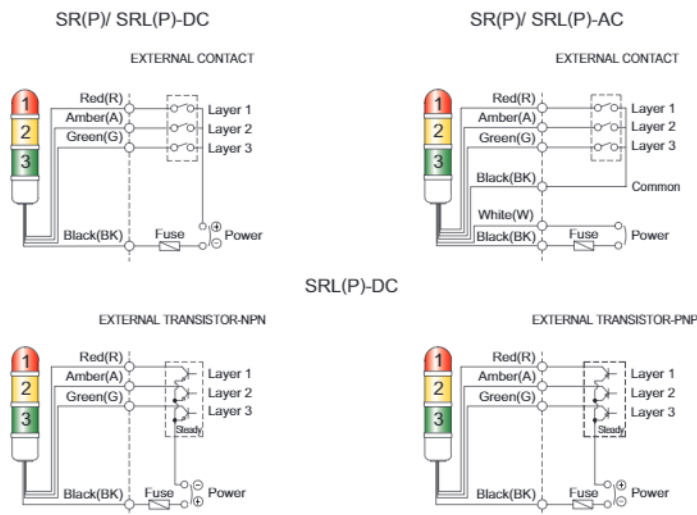

- External power line standard : UL1015 AWG18(0.75sq)×2C 400mm
- Signal line : UL1007 AWG22(0.3sq) 400mm
- DC type : Black output line is negative(-)

Please note for installation

- SRL/SRLP model wiring can be done with either external contacts or external transistors.
- In case of wiring with transistors, please select the proper transistor type : either NPN or PNP based on the source voltage setting.
- **The SR/SRP type warning lights use light bulbs which do not allow the use of transistors to register the connection. Please use external contacts.**

Customization

- 4 layers available upon request
- Customized color arrangement available

Ordering Specification

SRL	-	3	-	220	-	RAG
[Model number]		[Number of Tiers]		[Voltage]		[Color]
<ul style="list-style-type: none"> • SR • SRP • SRL • SRLP 		<ul style="list-style-type: none"> • 1-1tier • 2-2tiers • 3-3tiers 		<ul style="list-style-type: none"> • 12-DC12V • 24-DC24V • 110-AC110V • 220-AC220V 		<ul style="list-style-type: none"> • ● R-Red • ● A-Amber • ● G-Green