

## Warning light and electric horn combinations with excellent durability and perfectly enclosed structure, designed for vessels and heavy industry applications



- SHD series - Single electric horn type
- SHD2 series - Dual-facing electric horn type



### Common Specifications

- Warning light and electric horn combination models for vessels and heavy industries applications
- Aluminum housing and polycarbonate lens material provides excellent durability under seismic conditions
- Excellent hermetic structure that blocks water and dust
- Superior impact and shock resistance
- You can select a variety of sound and light sources (bulb, LED and xenon)
- Equipped with a wire guard
- Terminal box located inside the housing
- Can adjust sound volume and select sound pattern with the switches built inside the products
- Cable entry : 1/2"PF
- Materials : Lens-PC, Housing-Al, Protection cage-SUS316L, Reflector-PC, Multi-tiered reflector-Heat resistance ABS
- Standard housing color : MUNSELL No. 7.5BG 7/2
- Protection rating : IP66
- Certificates : KIMM, ABS, CE Compliant

### ■ A variety of selectable light source and function combinations

You can select from a variety of light sources for your the work environment, conditions, and purpose. Basic specifications are as follows :

- LED revolving type
- LED steady/flashing type
- Xenon lamp strobe type
- Bulb revolving type

User-selected LED strobe type and LED simulated revolving type are available upon request.

### ① A variety of selectable warning sounds and sound messages

You can convey specific information with a variety of 20 warning sounds and voice messages.

Sound	Pattern	Ch	Sound Tone
WS	5 Warning sounds	Ch1	Fire.A-ANG
		Ch2	Emergency WA-U(Yelp)
		Ch3	Ambulance PI-PO(Hi-low)
		Ch4	Machinery Fault
		Ch5	High Expansion
WP	5 Special warning sounds	Ch1	Fire.A-ANG
		Ch2	Abandon Alarm
		Ch3	Machinery Fault
		Ch4	High Expansion
		Ch5	7 Short Pl. / 1 Long
WM	5 Melodies	Ch1	Sweet Home
		Ch2	For Elise
		Ch3	Cuckoo's Waltz
		Ch4	Piano Sonata
		Ch5	Turkish March
WA	5 Alarms	Ch1	Beep Intermittent
		Ch2	Door Chime
		Ch3	Phone Ring
		Ch4	PI.PI.PI Short
		Ch5	Tripping Beat
WV	5 Customizable sound messages	Ch1 - Ch5	Customized sound tones

### ② Lens

- Polycarbonate lens material provides excellent impact resistance

### ③ Protection cage

- The durable wire guard is made of corrosion resistant stainless steel that prevents damage to the lens from external contact
- Materials : SUS316L

### ④ Housing

- The special aluminum body housing features superior durability
- The housing is corrosion resistant from a special anodized surface treatment process
- Materials : Al

### ⑤ Fully enclosed structure

- The tightly sealed warning light structure is waterproof and dustproof
- Protection rating : IP66

### SHD series Product Category Chart

SHD series		Light Source and Function	SHD2 series	
Standard Type	Protection Cage Equipped Type		Standard Type	Protection Cage Equipped Type
SHDLR	SHDLRP	LED revolving type	SHD2LR	SHD2LRP
SHDL	SHDLP	LED steady/flashing type	SHD2L	SHD2LP
SHDS	SHDSP	Xenon lamp strobe type	SHD2S	SHD2SP
SHD	SHDP	Bulb revolving type	SHD2	SHD2P

# SHD/ SHD2 series

Heavy-Duty Warning/ Signal Lights and Electric Horn for Vessels and Heavy Industry Applications

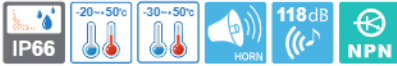

- SHD series
- Single Electric Horn
- SHD2 series
- Dual Electric Horn



SHDLR



SHD2LR



SHDLP



SHD2LP



SHD2L used in KTX tunnels for an evacuation alarm warning light system.

## SHDLR/ SHDLRP LED Revolving Warning Light & Electric Horn Combination

- Features high visibility in all directions with special concentrated LED light structure and multi side reflector
- Revolving speed : 120-140RPM
- Ambient operation temperature : -20°C to +50°C

Model number	Voltage	Current	Sound pattern and volume	Certificates	Weight	Color
SHDLR SHDLRP	DC12V	2.633A	• WS -5 Warning sounds : 118dB	KIMM ABS	• SHDLR DC-3.21kg AC-3.91kg	• R-Red • A-Amber • G-Green • B-Blue
	DC24V	1.288A	• WP -5 Special warning sounds : 118dB			
	AC110V	0.308A	• WM -5 Melodies : 118dB			
	AC220V	0.154A	• WA -5 Alarms : 116dB • WV -5 Customizable voices : 113dB			

## SHD2LR/ SHD2LRP LED Revolving Warning Light & Dual Electric Horn Combination

Model number	Voltage	Current	Sound pattern and volume	Certificates	Weight	Color
SHD2LR SHD2LRP	DC12V	4.844A	• WS -5 Warning sounds : 118dB×2	KIMM ABS	• SHD2LR DC-4.26kg AC-4.97kg	• R-Red • A-Amber • G-Green • B-Blue
	DC24V	2.255A	• WP -5 Special warning sounds : 118dB×2			
	AC110V	0.535A	• WM -5 Melodies : 118dB×2			
	AC220V	0.267A	• WA -5 Alarms : 116dB×2 • WV -5 Customizable voices : 113dB×2			

## SHDL/ SHDLP LED Steady/Flashing Warning Light & Electric Horn Combination

- Uniform and clear light diffusion with multi layered LED light distribution reflector
- Flashing rate : 60-80 flashes/min(Built-in steady/flashing selection switch)
- Ambient operation temperature : -30°C to +50°C

Model number	Voltage	Current	Sound pattern and volume	Certificates	Weight	Color
SHDL SHDLP	DC12V	2.511A	• WS -5 Warning sounds : 118dB	KIMM ABS	• SHDL DC-3.02kg AC-3.39kg	• R-Red • A-Amber • G-Green • B-Blue
	DC24V	1.222A	• WP -5 Special warning sounds : 118dB			
	AC110V	0.286A	• WM -5 Melodies : 118dB			
	AC220V	0.143A	• WA -5 Alarms : 116dB • WV -5 Customizable voices : 113dB			

## SHD2L/ SHD2LP LED Steady/Flashing Warning Light & Dual Electric Horn Combination

Model number	Voltage	Current	Sound pattern and volume	Certificates	Weight	Color
SHD2L SHD2LP	DC12V	4.722A	• WS -5 Warning sounds : 118dB×2	KIMM ABS	• SHD2L DC-4.07kg AC-4.45kg	• R-Red • A-Amber • G-Green • B-Blue
	DC24V	2.188A	• WP -5 Special warning sounds : 118dB×2			
	AC110V	0.513A	• WM -5 Melodies : 118dB×2			
	AC220V	0.256A	• WA -5 Alarms : 116dB×2 • WV -5 Customizable voices : 113dB×2			



# SHD/ SHD2 series

Warning Lights and Electric Horns for Vessels and Heavy Industry Applications

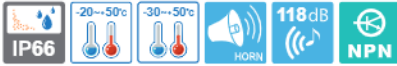

- SHD series  
-Single Electric Horn
- SHD2 series  
-Dual Electric Horn



SHDS

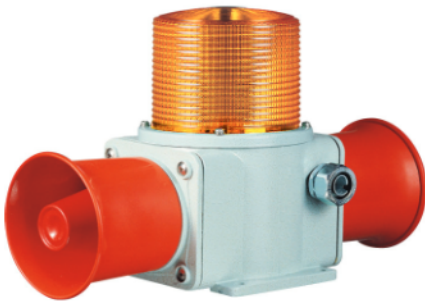

SHD2S



SHD

SHD2P

SHD/SHD2 series are equipped with flexible connector at cable entry. Cable gland is an optional item.



Flexible connector



Cable gland

## SHDS/ SHDSP Xenon Lamp Strobe Warning Light and Electric Horn Combination

- Flashing rate : 60-80 flashes/min
- Ambient operating temperature : -30°C to +50°C

Model number	Voltage	Current	Bulb			Sound pattern and volume	Certificates	Weight	Color
			Spec	Standard	Parts no				
SHDS SHDSP	DC12V	2.933A	200V -550V	EUB0641 -1A(G) U Type	48	<ul style="list-style-type: none"> <li>• WS-5 Warning sounds :118dB</li> <li>• WP -5 Special warning sounds :118dB</li> <li>• WM-5 Melodies : 118dB</li> <li>• WA-5 Alarms : 116dB</li> <li>• WV -5 Customizable voices : 113dB</li> </ul>		<ul style="list-style-type: none"> <li>• SHDS DC-3.05kg</li> <li>• SHDSP DC-3.3kg</li> </ul>	<ul style="list-style-type: none"> <li>• R-Red</li> <li>• A-Amber</li> <li>• G-Green</li> <li>• B-Blue</li> </ul>
	DC24V	1.411A							
	AC110V	0.360A							
	AC220V	0.220A							

## SHD2S/ SHD2SP Xenon Lamp Strobe Warning Light and Dual Electric Horn Combination

Model number	Voltage	Current	Bulb			Sound pattern and volume	Certificates	Weight	Color
			Spec	Standard	Parts no				
SHD2S SHD2SP	DC12V	5.144A	200V -550V	EUB0641 -1A(G) U Type	48	<ul style="list-style-type: none"> <li>• WS-5 Warning sounds :118dB×2</li> <li>• WP -5 Special warning sounds :118dB×2</li> <li>• WM-5 Melodies : 118dB×2</li> <li>• WA-5 Alarms : 116dB×2</li> <li>• WV -5 Customizable voices : 113dB×2</li> </ul>		<ul style="list-style-type: none"> <li>• SHD2S DC-4.11kg</li> <li>• SHD2SP DC-4.36kg</li> </ul>	<ul style="list-style-type: none"> <li>• R-Red</li> <li>• A-Amber</li> <li>• G-Green</li> <li>• B-Blue</li> </ul>
	DC24V	2.377A							
	AC110V	0.586A							
	AC220V	0.333A							

## SHD/ SHDP Bulb Revolving Warning light and Electric Horn Combination

- Revolving speed : 120 - 140RPM
- Ambient operating temperature : -20°C to +50°C

Model number	Voltage	Current	Bulb			Sound pattern and volume	Certificates	Weight	Color
			Spec	Standard	Parts no				
SHD SHDP	DC12V	3.755A	12V15W	G23 15S	17	<ul style="list-style-type: none"> <li>• WS-5 Warning sounds :118dB</li> <li>• WP -5 Special warning sounds :118dB</li> <li>• WM-5 Melodies : 118dB</li> <li>• WA-5 Alarms : 116dB</li> <li>• WV -5 Customizable voices : 113dB</li> </ul>		<ul style="list-style-type: none"> <li>• SHD DC-3.18kg</li> <li>• SHDP DC-3.43kg</li> </ul>	<ul style="list-style-type: none"> <li>• R-Red</li> <li>• A-Amber</li> <li>• G-Green</li> <li>• B-Blue</li> </ul>
	DC24V	1.788A	24V15W	G23 15S	18				
	AC110V	0.422A	12V15W	G23 15S	17				
	AC220V	0.211A	12V15W	G23 15S	17				

## SHD2/ SHD2P Bulb Revolving Warning light and Dual Electric Horn Combination

Model number	Voltage	Current	Bulb			Sound pattern and volume	Certificates	Weight	Color
			Spec	Standard	Parts no				
SHD2 SHD2P	DC12V	5.966A	12V15W	G23 15S	17	<ul style="list-style-type: none"> <li>• WS-5 Warning sounds :118dB×2</li> <li>• WP -5 Special warning sounds :118dB×2</li> <li>• WM-5 Melodies : 118dB×2</li> <li>• WA-5 Alarms : 116dB×2</li> <li>• WV -5 Customizable voices : 113dB×2</li> </ul>		<ul style="list-style-type: none"> <li>• SHD2 DC-4.23kg</li> <li>• SHD2P DC-4.48kg</li> </ul>	<ul style="list-style-type: none"> <li>• R-Red</li> <li>• A-Amber</li> <li>• G-Green</li> <li>• B-Blue</li> </ul>
	DC24V	2.755A	24V15W	G23 15S	18				
	AC110V	0.648A	12V15W	G23 15S	17				
	AC220V	0.324A	12V15W	G23 15S	17				

# SHD/ SHD2 series

Warning Lights and Electric Horns for Vessels and Heavy Industry Applications



## Technical Diagram

(Units : mm)

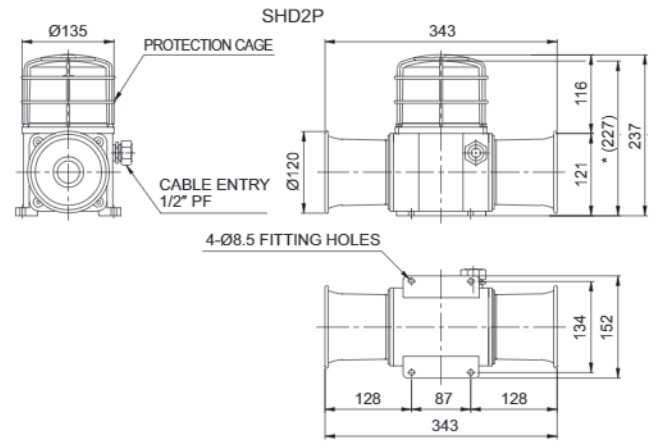
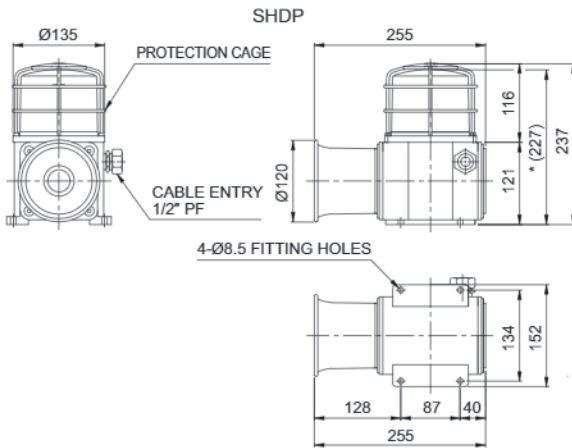

\* (227) represents SHD size without protection cage.

\* (227) represents SHD2 size without protection cage.

## Sound Selection Instructions and Wiring

- Standard Type : Select sound using the switch inside of the unit. When you turn on the dip switch for each channel, the designated sound will be played.
- Customization : External contact(LC)

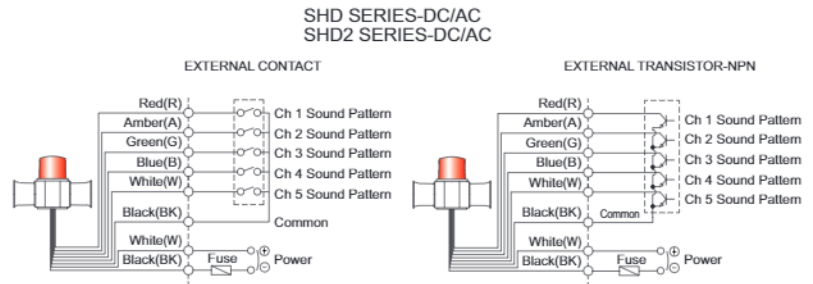
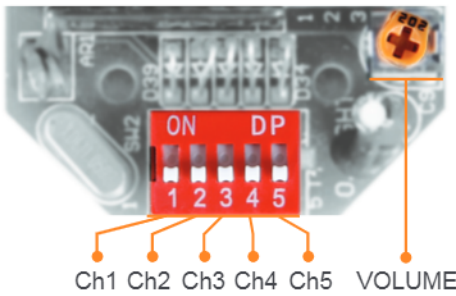

## Customization

- Customized cable entry(3/4"PF) available(Standard : 1/2"PF)
- Cable gland type
- Customized external sound line type available : SHD/SHD2 series have built-in switch for sound tone selection

### ■ Sound tones for standard model

Sound	Built-in sound	Ch	Sound tone	Sound	Built-in sound	Ch	Sound tone
WS	5 Warning sounds	Ch1	Fire.A-ANG	WM	5 Melodies	Ch1	Sweet Home
		Ch2	Emergency WA-U(Yelp)			Ch2	For Elise
		Ch3	Ambulance PI-PO(Hi-low)			Ch3	Cuckoo's Waltz
		Ch4	Machinery Fault			Ch4	Piano Sonata
		Ch5	High Expansion			Ch5	Turkish March
WP	5 Special warning sounds	Ch1	Fire.A-ANG	WA	5 Alarms	Ch1	Beep Intermittent
		Ch2	Abandon Alarm			Ch2	Door Chime
		Ch3	Machinery Fault			Ch3	Phone Ring
		Ch4	High Expansion			Ch4	PI.PI.PI Short
		Ch5	7 Short PI. / 1 Long			Ch5	Tripping Beat
WV	5 Customizable Voices	Ch1-Ch5	Customized sound				

\* Standard model has 5 warning sounds(WS), 5 special warning sounds(WP), 5 melodies(WM), 5 alarms(WA) and 5 customizable voices(WV).

## Ordering Specification

<b>SHD2L</b>	-	<b>WA</b>	-	<b>24</b>	-	<b>R</b>
[Model number]		[Sound]		[Voltage]		[Color]
<ul style="list-style-type: none"> <li>• SHDLR • SHDLRP • SHD2LR • SHD2LRP</li> <li>• SHDL • SHDLP • SHD2L • SHD2LP</li> <li>• SHDS • SHDSP • SHD2S • SHD2SP</li> <li>• SHD • SHDP • SHD2 • SHD2P</li> </ul>		<ul style="list-style-type: none"> <li>• WS-Warning sounds</li> <li>• WP-Special warning sounds</li> <li>• WM-Melodies</li> <li>• WA-Alarms</li> <li>• WV-Customizable voices</li> </ul>		<ul style="list-style-type: none"> <li>• 12-DC12V</li> <li>• 24-DC24V</li> <li>• 110-AC110V</li> <li>• 220-AC220V</li> </ul>		<ul style="list-style-type: none"> <li>• R-Red</li> <li>• A-Amber</li> <li>• G-Green</li> <li>• B-Blue</li> </ul>

