



### Water, vibration and oil resistant LED work light, suitable for machine tools applications and high temperature water cleaning environments



#### Common Specifications(QML/ QMHL)

- Excellent oil resistance with a special sealing structure with IP67 protection rating, suitable for machine tool applications with cutting fluids
- Suitable for high pressure and high temperature water cleaning environments(IP69K)
- Tempered glass prevents damage from machine tool chips
- Foreign substances do not accumulate on the shielding glass surface of the working light due to its flush structure to the housing structure of the product
- Can select between QML model (Anti-glare type) and QMHL model (High luminance type) depending on your work conditions
- An external power supply is not needed for the AC type product; AC voltage can be applied directly to the product
- Can select from a variety of bracket options from direct mount, tilt mount, and pan/ tilt mount type to fit your work environment or lighting condition needs
- Can customize the product with the M12 connector if requested
- Customized oil resistant cable attached type available
- Certificates : CE Compliant, UL Listed



#### Tilt/ Pan Type MF Bracket, Water and Oil Resistant

SIDE VIEW

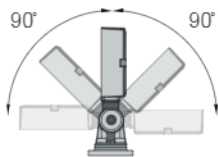

TOP VIEW

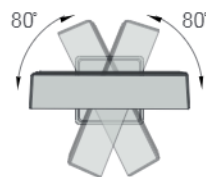

- Water and oil resistant MF type brackets protect output cable from cutting fluid and chips
- Has a tilt adjustment angle of 180° and a pan angle of 160°

#### Tilt Type K Bracket

SIDE VIEW

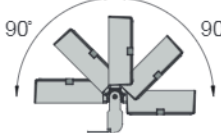

Has tilt adjustment with wide angle of 180°

#### Cable entry M12 connector attached type

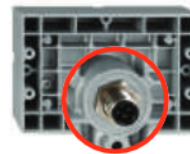

Customized cable entry M12 connector attached type available

#### Test Conditions/ Regulations

Vibration Resistance Test	<ul style="list-style-type: none"> <li>• Acceleration : 20m/s<sup>2</sup></li> <li>• Duration : 1 octave/min</li> <li>• Range of frequency : 10-150Hz</li> <li>• Amplitude : 10 times maximum 7.5mm, direction : test 10times in 3 directions(X, Y, Z)</li> </ul>
Shock Resistance Test	<ul style="list-style-type: none"> <li>• Acceleration : 20g</li> <li>• Directions : ±X, ±Y, ±Z</li> <li>• Numbers : 3 times each directions</li> <li>• Time period : 11ms for each direction</li> <li>• Waveform : Half sine</li> </ul>
Oil Resistance Test	<ul style="list-style-type: none"> <li>• General test : Tested in water soluble and non-water soluble flooded environments for 500 hours.</li> <li>• High temperature oil resistance test : Place the object in a constant temperature water bath at 80°C for two hours and then submerge the object in the room temperature oil diluent for 24hours.</li> </ul>
Solid Particle Protection Test(IP6X)	<ul style="list-style-type: none"> <li>• After reducing the pressure inside the test object, spray talcum powder with a nominal diameter of 50um for 2 hours at 40-60meters/hour inside the dust chamber.</li> <li>• IEC60529</li> </ul>
Liquid Ingress Protection Test(IPX7)	<ul style="list-style-type: none"> <li>• Test ingress by putting the object under 1000mm water with 2bar of pressure for 30 mins</li> </ul>
High-pressure, High-temperature Wash-down Test (IP69K)	<ul style="list-style-type: none"> <li>• Spray nozzle provides 80°C water with pressure of 80–100 bar and a flow rate of 14–16 L/min to the object</li> <li>• Distance between spray nozzle and the test object : 10-15cm</li> <li>• Water spray angle : 0°, 30°, 60°, 90°</li> <li>• The nozzle is held at 4 of each angle for 30 seconds</li> <li>• DIN 40050 PART9</li> </ul>

# QML/QMHL

Water, Vibration and Oil Resistant  
LED Work Lights with IP67/ IP69K Protection



## QML-150/ QML-250

- Equipped anti-glare filter
- Suitable for environments that require stable intensity illumination for improved visibility



QML-150-D



QML-250-D



QML-150-K



QML-250-K



QML-150-MF



QML-250-MF

## QMHL-150/ QMHL-250

- High intensity illumination and condenser lens combination
- High intensity illumination allows for the environment both long distance and straightness are required



QMHL-150-D



QMHL-250-D



QMHL-150-K



QMHL-250-K



QMHL-150-MF



QMHL-250-MF

### Optics Specifications

Model	QML-150-D QML-150-K QML-150-MF	QML-250-D QML-250-K QML-250-MF	QMHL-150-D QMHL-150-K QMHL-150-MF	QMHL-250-D QMHL-250-K QMHL-250-MF
Lens color	Translucent		Transparent	
Light color	Cooldaylight			
Color temperature	6,000-7,000K			
Luminous flux	875lm	2,014lm	884lm	1,892lm
Efficacy (lm/W)	620lux	890lux	1,000lux	1,900lux

### Specifications

Model	QML-150-D QML-150-K QML-150-MF	QML-250-D QML-250-K QML-250-MF	QMHL-150-D QMHL-150-K QMHL-150-MF	QMHL-250-D QMHL-250-K QMHL-250-MF
Voltage	DC24V		DC24V	DC24V
Range for operation voltage	DC21.5V-26.5V			
Power consumption	14W	30W	12W	25W
Insulation resistance	Min. 100MΩ(500V DC mega ohm meter)			
Withstanding voltage	DC : 500V AC, 60Hz, 1 minute			
Operating temperature	-30°C to +60°C			
Protection rating	IP67/ IP69K			
Materials	Housing : AI, Lens : Tempered glass, Bracket : K type-STS430/MF type-AI			
Certification	CE DC24V only UL DC24V only (QML series only)			
Weight(Approx.)	QML-150-D : 0.75kg QML-150-K : 0.93kg QML-150-MF : 0.98kg	QML-250-D : 1.30kg QML-250-K : 1.46kg QML-250-MF : 1.52kg	QMHL-150-D : 0.95kg QMHL-150-K : 1.05kg QMHL-150-MF : 1.45kg	QMHL-250-D : 1.20kg QMHL-250-K : 1.30kg QMHL-250-MF : 1.70kg

# QML/QMHL

Water, Vibration and Oil Resistant  
LED Work Lights with IP67/ IP69K Protection

## Light Distribution and Illuminance

Model	QML-150-D QML-150-K QML-150-MF	QML-250-D QML-250-K QML-250-MF	QMHL-150-D QMHL-150-K QMHL-150-MF	QMHL-250-D QMHL-250-K QMHL-250-MF
Light Distribution Curve				
Illumination Feature				



## Technical Diagram

(Units : mm)

QML/ QMHL-150-D

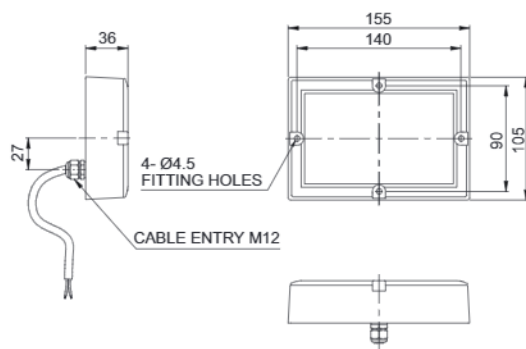

QML/ QMHL-150-K

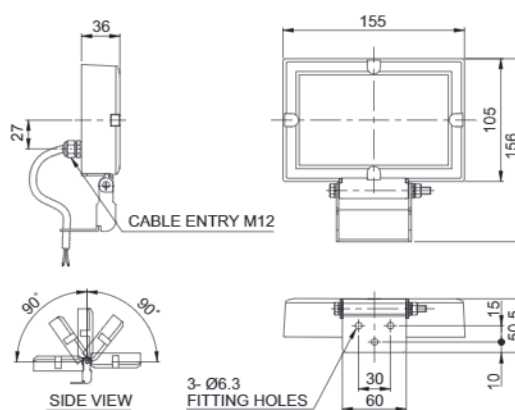

QML/ QMHL-150-MF

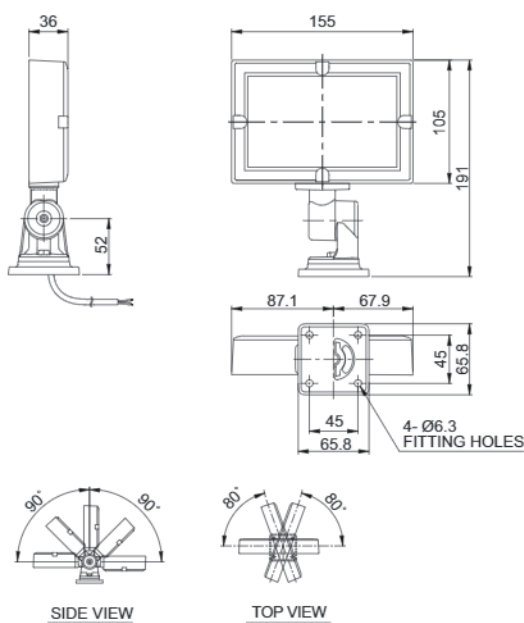

※ External power line - Dura & Flex-F VU(0.5sq) x 2C 450mm

# QML/QMHL

Water, Vibration and Oil Resistant  
LED Work Lights with IP67/ IP69K Protection



## Technical Diagram

(Units : mm)

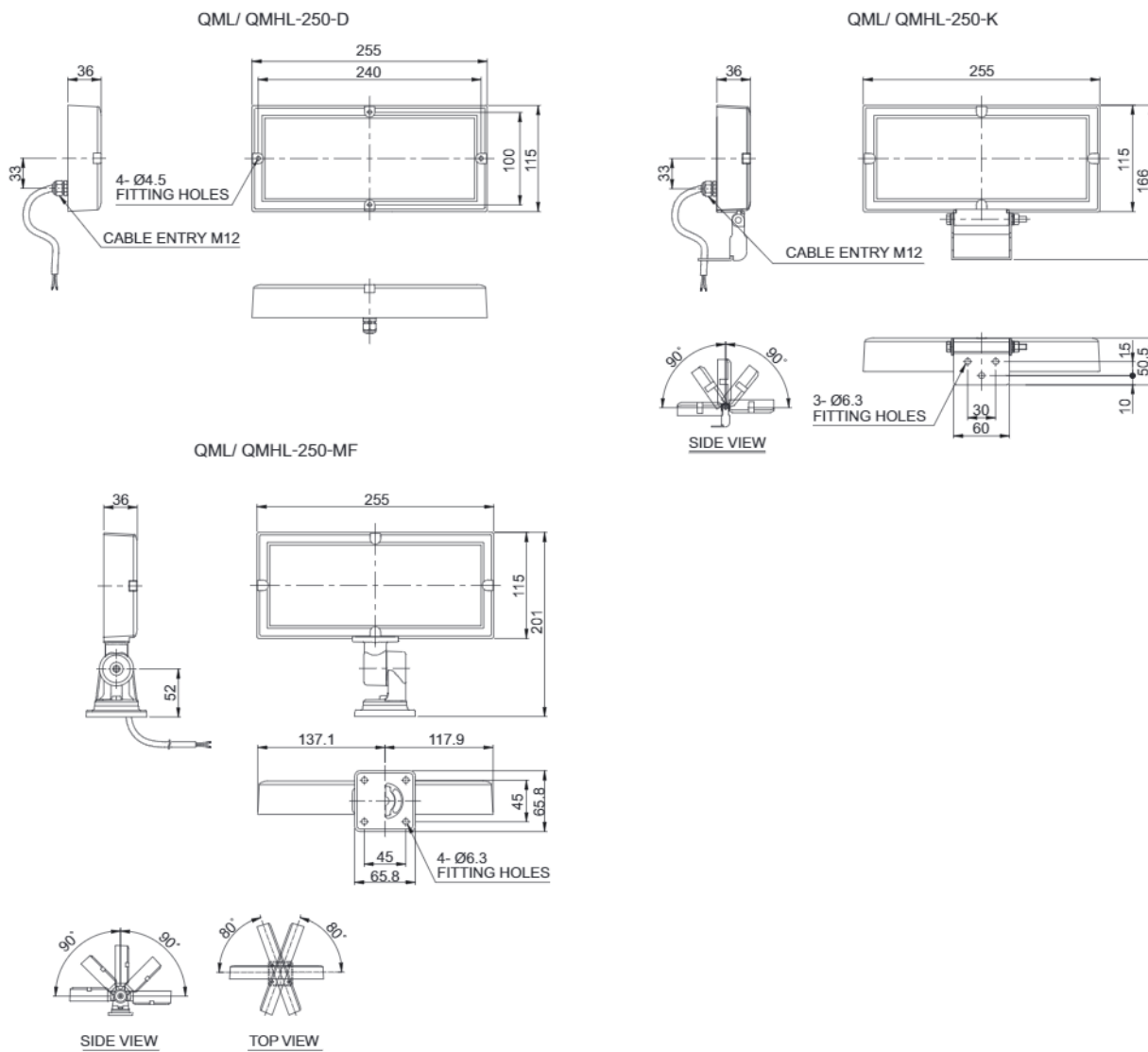

※ External power line - Dura & Flex-F VU(0.5sq) x 2C 450mm



## Ordering Specification

<b>QML</b>	-	<b>150</b>	-	<b>D</b>	-	<b>24</b>
[Model number]		[Product length]		[Mount bracket]		[Voltage]
<ul style="list-style-type: none"> <li>• QML : Anti-Glare</li> <li>• QMHL : High illumination</li> </ul>		<ul style="list-style-type: none"> <li>• 150 : 155mm</li> <li>• 250 : 255mm</li> </ul>		<ul style="list-style-type: none"> <li>• D : Self stand</li> <li>• K : Vertical angle adjustment</li> <li>• MF : Vertical, horizontality angle adjustment</li> </ul>		<ul style="list-style-type: none"> <li>• 24-DC24V</li> </ul>



Please check the safety manual before use, accidents such as fire or electric shock can occur if the safety manual is not followed.

This product can be changed without any notification. Latest information is on the website.